

UMTRI-90-38
VERSION 04

Archive
80604

The "UMIVOR" Manual

The University
of Michigan
Transportation
Research Institute

UMIVOR—UMIVOR—UMIVOR—UMIVOR



Technical Report Documentation Page

1. Report No. UMTRI - 90 - 38	2. Government Accession No.	3. Recipient's Catalog No.	
4. Title and Subtitle The Umivor Manual: Version 4		5. Report Date October 1, 1990	
		6. Performing Organization Code	
7. Author(s) Marion J. Bowman		8. Performing Organization Report No. UMTRI - 90 - 38	
9. Performing Organization Name and Address Transportation Research Institute The University of Michigan Ann Arbor, Michigan 48109-2150		10. Work Unit No. (TRAIS)	
		11. Contract or Grant No. 361124	
12. Sponsoring Agency Name and Address Motor Vehicle Manufacturers Assoc. 7430 2nd Ave., Suite 300 Detroit, Michigan 48202		13. Type of Report and Period Covered	
		14. Sponsoring Agency Code	
15. Supplementary Notes			
16. Abstract <p>This report documents the investigation practices, editing conventions and reference materials in preparing Mutli-disciplinary Accident Investigation reported case vehicles for processing into the Transportation Research Institute's Accident Data Bank.</p> <p>The text documents the October 1, 1990 revised interpretations of each variable and includes expanded reference materials for use with the UMIVOR (University of Michigan In-depth Vehicle and Occupant Report Form.)</p>			
17. Key Words Investigation Practices, Editing Conventions, Reference Materials, Revised Interpretations		18. Distribution Statement Unlimited	
19. Security Classif. (of this report) Unclassified	20. Security Classif. (of this page) Unclassified	21. No. of Pages 188	22. Price

**THE "UMIVOR" MANUAL
VERSION 04**

**Instructions and Interpretations for Investigators,
Editors, and Data Analysts on the Use of the UMIVOR
(University of Michigan In-depth Vehicle Occupant Report)**

Marion J. Bowman

October 1, 1990

**The University of Michigan
Transportation Research Institute
Transportation Data Center
Ann Arbor, Michigan**

Acknowledgements

The UMIVOR Manual was developed, written and published with the assistance of many people over the years (e.g. Corwin Moore, Robert Scott, John Green, Charles Compton, Wendy Barhydt, Mary Helen Eschman, Harold Sherman, Mary Bennett, Tim Compton, and Jamie Moore.) Each has had a significant impact on this revision and their influence and assistance is greatly appreciated.

Funding for this development, maintenance and revision as well as for file building of the UMIVOR (University of Michigan In-Depth Vehicle and Occupant Report) field form has come from the MVMA (Motor Vehicle Manufacturers Association). The continuing support of that agency is gratefully acknowledged.

THE "UMIVOR" (Foreword)

The University of Michigan In-Depth Vehicle Occupant Report (UMIVOR) Form was developed for the field recording of vehicle damage and occupant injuries sustained in motor vehicle traffic accidents. The report was developed by the University of Michigan's Transportation Research Institute (UMTRI) as a new concept in accident reporting.

The report is designed to be used primarily for passenger cars, light trucks, and vans. It is modular in nature so that future modifications of the format can be made easily by adding new modules or by dropping old ones. Provisions have been made in the administrative module to include optional user-defined elements. The report is also designed for data entry and computerization with specific module identifiers and column numbers. All measurements are recorded in metric units.

This current revised format of the report is the result of extensive internal development, discussions with many end-user groups, and operational use in actual field situations. The report is accompanied at UMTRI by computer programs to produce working data sets from the field-recorded data.

The purposes of this UMIVOR Manual are threefold:

- a) To instruct field accident investigators in the proper completion of the UMIVOR;
- b) To guide editors in their subsequent administrative quality control of these Reports prior to their submission for computer entry;
- c) To assist data analysts in their understanding and use of the contents of the cumulative UMIVOR file in their respective inquiries.

This Manual attempts both to provide instruction in the use of the UMIVOR, and to provide a unified set of interpretations intended to minimize variations between different individual Reports.

TABLE OF CONTENTS

Foreword i

General Instructions
 Scope and Eligibility; The Collision Sequence;
 Damage to Ignore; Blanks and Non-numerics;
 Reference Sources; Future Changes 1

Module AD: Administrative Information
 Basic Information; Supplemental Information 7

Module GI: General Information
 Time; Location; Environmental Conditions;
 Mechanical Malfunctions; Crash Details;
 Driver Impairment; Post Crash Detail;
 Accident Schematic 11

Module OV: Other Vehicle
 Criteria for Selection; Description; Damage 21

Module VD: Vehicle Description
 Identification; Type; Equipment; Damage Diagram 27

Module DA: Damage
 Primary Impact; Secondary Impact; Crush;
 Chronology and Sequence 35

Module CR: Crash Reconstruction
 CRASH Input Measures, Output Results 41

Module WT: Wheels and Tires
 Wheels; Tire Type, Construction, Size 43

Module FT: Fuel and Fuel Tanks
 Type of Fuel; Main Tank; Auxiliary Tank 45

Module FL: Fuel Leakage
 Leak Component; Source; Extent 47

Module FR: Fire
 Propagation Rate; Severity; Source 49

Module ED: Exterior Damage
 Hood; Engine Mount; Flexible Coupling;
 Telescoping Unit; Left Pillars and Doors;
 Rear Side; Right Pillars and Doors;
 Windshield 51

Module SC: Steering Wheel and Column
 Steering Wheel; Steering Column; Steering
 Column EAD; Shear Capsules; Column Movement 61

Module IT: Intrusion
 General Description; Side-Door Intrusion 65

Module ID: Interior Damage
 Sides; Front; Instrument Panel 69

Module ST: Seats
 Front Seats, Back, Head Restraints, Adjustment;
 Second Seats; Third Seats; Rear Head Restraints 77

Module AB: Airbag
 Location; Condition; Damage Diagram 87

Module OC: Occupant Information
 Identification; Position; Description;
 Medical Conditions; Restraint System;
 Ejection; Head Restraint; Injury Pictorial 89

Module IC: Injury Classification
 Contact Areas; Primary and Secondary OIC's 99

APPENDICES
 (The list of Appendices is on the next page.) 107

ANNOTATED BIBLIOGRAPHY
 Vehicle Identification; Vehicle Specifications;
 Vehicle Damage Reporting; Medical and
 Physiological Conditions 185

LIST OF TABLES

Table 1.	List of Permissible Blanks	3
Table 2.	List of Permissible Non-numeric Responses	3
Table 3.	List of Entries Which May Contain Either the Number "Zero" or the Letter "O"	4
Table 4.	ISS: Definition of Body Regions	92
Table 5.	Passenger-Car Manuf/Body-Code Suffixes	115
Table 6.	Replacement Windshield Monogram Marks	175

LIST OF APPENDICES

Team Codes	107
State Codes	109
Man/Body and Make/Model Codes	111
English-to-Metric Conversions	129
Optional Damage Pictorial Diagrams	131
Pillar Structure	169
Windshield Codes	175
OIC Codes & Valid Combinations	181

GENERAL INSTRUCTIONS

(UMIVOR Version 04; 10/01/90)

TYPE OF VEHICLE TO REPORT

The UMIVOR Form is designed primarily for use with passenger cars, with multi-purpose passenger vehicles (MPV's), and with light trucks (including pickups) and vans of less than 4500 Kg (10,000 lbs) gross vehicle weight (GVW). Data for large trucks involved in crashes are recorded on CPIR-B Forms and correspondingly, data for School Buses involved in crashes continue to be placed on the CPIR-A Form.

THE SCOPE OF EACH UMIVOR REPORT

Each UMIVOR Report is intended to record the collision damage to one Case Vehicle and injuries to its occupants for a specific accident.

A separate UMIVOR Report must be completed for each vehicle selected to be a Case Vehicle in the accident.

If a particular Case Vehicle carried more than one occupant, an additional set of "occupant pages" (OC-1 through OC-3, and IC-2) must be completed for each.

THE "COLLISION SEQUENCE"

The first "collision sequence" started at the point in time of the first damage- or injury-producing event experienced by any vehicle involved in the overall accident. That first collision sequence then continued until all vehicles and objects contacted came to a complete halt.

During this collision sequence, any of the vehicles involved may have experienced multiple impacts, including additional impacts with some vehicle or object already contacted.

If, after all vehicles and objects involved in a particular collision sequence had come to a complete halt, one of them was again struck, this began a second collision sequence. This second collision sequence constitutes a separate accident, for purposes of the UMIVOR. If it is investigated, it must be assigned its own Accident Identification Number, and must be reported on a separate UMIVOR Report.

HARDWARE OR EQUIPMENT DAMAGE TO BE CODED

The damage described in the UMIVOR Report may pertain only to that hardware or equipment which was part of the Case Vehicle as it was originally manufactured. Damage to "after-market" hardware, equipment, or devices must not be coded, except as allowed for specific entries in later sections of this Manual.

RECORDING OF FIRE DAMAGE

The UMIVOR Report is designed primarily to record damage or injury experienced during a collision between a Case Vehicle and some other object or vehicle. Code fire damage only if this fire resulted from such a collision sequence.

COMPLETION OF INDIVIDUAL RESPONSES

The responses on the UMIVOR are destined for computer entry. Not more than a single alphanumeric entry is permissible for each column number.

(Note that a limited number of responses do not have column numbers associated with them. These will not be entered into the computer, but instead will be maintained only in the "hard copy" file to assist data analysts in further understanding the details involved. This information is also useful to the editor in verifying certain entries, and in checking for consistency.)

Each response on the UMIVOR Report should be completed. The only spaces which may be left blank are those listed in Table One on the following page. (These will each be discussed individually in subsequent sections of this Manual.)

NON-NUMERIC ENTRIES

The data analysis program for the UMIVOR File requires numeric entries. Of those responses destined for computer entry, only those listed below may have non-numeric answers. A discussion of each of these entries, and in some instances the range of specific non-numeric characters which are acceptable, can be found in subsequent appropriate sections of this Manual.

TABLE 1
List of Permissible Blanks

Page Number	Column Number	Page Number	Column Number
AD-1	18-37	FL-1	14-53
OV-1	entire	FR-1	14-17
VD-1	13-29	IT-3 (upper)	14 plus entire page
DA-1 (lower)	14-55	(lower)	13-37
DA-2	37-66	IT-4	entire page
CR-2	47-65	IC-2	all

TABLE 2
List of Permissible Non-numeric Responses

Page Number	Column Number	Page Number	Column Number
AD-1	18-37	CR-2	17,21,35, 39,51,55, 69,73
OV-1	13-29	WT-1	25-64
VD-1	13-29	ED-6	74-75
DA-1 (Format 02, 03)	23-26 30-33, 44-47, 51-54	IT-3 (middle)	22
		IT-4 (middle)	22
		IC-2 (all cards)	21-24 26-29

DISTINGUISHING LETTER "O" FROM NUMBER "ZERO" RESPONSES

Because most of the entries on the UMIVOR Report are numbers instead of letters, the number "zero" is more frequently used than the letter "O." Therefore, the following convention has been adopted:

- a) To designate the number "zero," enter "0."
- b) To designate the letter "O," enter "Ø."

(This convention has been adopted to ease the task of filling out the UMIVOR Report, and yet to give an unmistakable entry to the data-entry operator and to the data analyst.)

Following this convention is especially important for those entries in which either the number "zero" or the letter "O" is permissible. These include the entries listed in the following table.

TABLE 3
List of Entries Which May Contain
Either the Number "ZERO" or the Letter "O"

Page Number	Column Number	Response Content
AD-1	18-37	Team Report Number
OV-1	13-29	Other Vehicle VIN
VD-1	13-29	Case Vehicle VIN
WT-1	13-52 (lower)	Tire Size Code
ED-6	74-75	Windshield Codes

RECORDING OF ADDITIONAL ADMINISTRATIVE INFORMATION

The Administrative Module (page AD-1) may be expanded to include additional information pertaining to the administration of a particular project or contract. This (and the modularized concept of the UMIVOR in general) are intended to provide sufficient flexibility for expanding future needs.

ADDITIONAL REFERENCE SOURCES

The APPENDICES of this UMIVOR Manual contain certain additional reference materials and optional pictorial pages which the investigator might find useful.

However, no attempt has been made to satisfy all possible reference material needs. Instead, it is presumed that the investigator and editor have immediate access to certain additional materials. These are identified and discussed briefly in the ANNOTATED BIBLIOGRAPHY.

FUTURE REVISIONS OF THE UMIVOR FORM

Individual "modules" within the UMIVOR Report will be revised on an "as needed basis, possibly with new modules added or old ones deleted as seems necessary. These revisions will be designed to take maximum benefit of the data file already built on prior versions of the UMIVOR.

Please send inquiries concerning the UMIVOR Form to the following address:

University of Michigan
Transportation Research Institute
Data Center
Attention: UMIVOR Editor
2901 Baxter Road
Ann Arbor, MI 48109-2150

Module AD: **ADMINISTRATIVE INFORMATION**

The first eight columns on this page are duplicated during the file-build process onto each subsequent data card. Please be sure that the entries in these first eight columns are precisely correct.

TEAM CODE (page AD-1, columns 1-2)

The Team Code is a unique, two-digit numeric code assigned to each Investigating Team. A list of these codes can be found in the Appendix: TEAM CODES.

ACCIDENT ID (columns 3-7)

The Accident Identification Number is a unique, five-digit numeric code assigned by the Investigating Team to each accident. All vehicles in that accident for which investigation reports have been completed should be identified in their reports by this same number.

The exact numbering sequence to be used is left up to the Investigating Team, but the same sequence format should be used consistently for all of its UMIVOR reports. If this number is less than five digits, right-justify the entry (namely, move the entry as far to the right as possible in the column spaces available), and use leading zero's if necessary to fill up the five-digit field.

The following describes a numbering sequence option which has worked well in the past for those teams which investigate less than a thousand accidents each year:

The first two digits designate the calendar year during which the investigation was begun. The last three digits are a numerically ascending sequence for investigations begun that year.

The twenty-third accident investigated in 1979 would have an Accident Identification Number of "79023," for instance.

VEHICLE NUMBER (column 8)

This is the number assigned by the Investigating Team to this particular Case Vehicle in this accident. Any single digit other than "0" may be used.

MODULE (columns 9-10)

The UMIVOR is divided into a series of "modules," each identified in the UMIVOR data set by a two-letter designation. For this and each of the subsequent modules, this designator is already printed on the page.

FORMAT (columns 11-12)

The longer modules are split into smaller units, called "formats," to ease key-punching and data entry. The two-character "format" designator is already printed on the pages of the UMIVOR.

FORM VERSION (columns 13-14)

This is the fourth version of the UMIVOR. Subsequent revisions will be numbered sequentially. This UMIVOR Manual applies only to the revision number "04," dated October 1, 1990.

NUMBER OF CASE VEHICLES IN ACCIDENT (column 15)

Record the total number of case vehicles reported on UMIVOR forms. This number should also include any large truck reported on a CPIR-B Form, or a school bus reported on a CPIR-A Form, if such a truck or bus was involved in the same collision sequence.

NUMBER OF SLIDES (columns 16-17)

Record the number of slides submitted with this particular UMIVOR report. The following codes can be used:

00	No slides submitted.
01-97	Actual number of slides submitted.
98	98 or more slides submitted.
99	Unknown number of slides submitted.

TEAM REPORT NUMBER (columns 18-37)

The Investigating Team may specify any unique alpha-numeric identifier (including blank spaces) not to exceed a total of twenty characters. Once this general format has been established, it should be followed for all subsequent UMIVOR reports for that Team. Interior and trailing blanks are permissible.

The remainder of the ADMINISTRATIVE INFORMATION page should be completed, even though the information provided will not be entered into the permanent file.

DATE OF FIELD INVESTIGATION

Enter the month (01-12), day (01-31), and last two digits of the year (00-98). If any of these three data elements is unknown, enter "99" for that data element only.

INVESTIGATOR

Record here the name or initials of the principal investigator.

LOCATION WHERE VEHICLE WAS EVALUATED

Specify the physical location (the name of the particular impounding area or junk yard, or the street address or intersection of the accident, for instance) where the Case Vehicle was initially examined.

PHOTO RECORDS

Indicate by circling the type of the original photo records made and retained by the Investigating Team (not just those submitted with this UMIVOR report).

The Administrative Module (page AD-1) may be expanded to include additional information pertaining to the administration of a particular project or contract. This (and the modularized concept of the UMIVOR in general) are intended to provide sufficient flexibility for expanding future needs.

REPORT PREPARED BY: _____

The name of the person preparing the report should be entered here. This may or may not be the investigator.

Module GI: GENERAL INFORMATION**TIME** (page GI-1)**DATE OF COLLISION** (columns 13-18)

Enter the month (01-12), day (01-31), and last two digits of the year (00-98). If any of these three data elements is unknown, enter "99" for that data element only.

HOUR OF COLLISION (columns 19-22)

Use a twenty-four hour clock, local time.

If only an approximate hour integer is known, enter "99" in the "minutes" block (columns 21-22). For example, "about 4 PM" would be entered as "1699."

If no information about the exact time or clock hour is available, enter "9999."

LOCATION**STATE** (columns 23-24)

The state location code consists of two digits, and is taken from the Federal Information Processing Standards (FIPS) Publication. See Appendix: STATE CODES.

AREA (column 25)

"Urban" (1) includes suburban. "Rural" (2) is intended for more truly remote conditions from which substantial cross-traffic would not normally be expected.

ENVIRONMENTAL CONDITIONS

Report environmental conditions for the time and place of the first damage- or injury-producing impact of this particular Case Vehicle.

LIMITED-ACCESS HIGHWAY (column 26)

This refers specifically to Interstate-type and other highways which have no "at-grade" crossings.

ROAD TOTAL TRAFFIC LANES (column 27)

This question refers to the road on which the Case Vehicle was traveling, and may be different for other vehicles involved in the accident.

If the collision happened at an intersection, choose the roadway that best describes the Case Vehicle's location at the point of first impact. If the Case Vehicle was making a turn and its sides were parallel with the new roadway, the Case Vehicle had completed the turn and is considered to have been on the new roadway. If it had not yet completed the turn, the original road should be coded.

Neither parking lanes nor bicycle lanes are counted as traffic lanes, unless they have been designated as "turning lanes" at an intersection. They are not, however, considered to be "off the roadway," for instance as would be recorded on page GI-3 (column 47).

No distinction is made between one-way and two-way streets. Nor is any distinction made between "divided" or "undivided" roads of less than four lanes. However, code "4" is only for four or more undivided lanes, and code "5" is for four or more divided lanes.

"Botts Dots" alone do not constitute a median. However, a painted median (with or without Botts Dotts) is considered to be a divider if it exceeds one car length (about 16 feet) in width, and extends along the roadway for more than ten car lengths.

Physical barriers or islands constitute medians regardless of width if they parallel the traffic way, are greater than ten car-lengths long, and provide substantial physical impediment to vehicular cross-over traffic flow.

"Other" (7) should be used for other significant but otherwise unclassified types of roadway.

Ramps are considered one lane. Use code (1).

INTERSECTING ROAD, TOTAL LANES (column 28)

The codes for the previous question are also used here for the intersecting roadway in accidents that occur at intersections. Any directly intersecting roadway should always be coded, whether or not it was significantly involved.

However, a "driveway" (6) is coded only if it was significantly involved. (For instance, a contacted vehicle was emerging from a driveway, or a driveway is suspected of having constituted a significant visual obstruction or a possible source for driver confusion.)

"Not applicable" (8) should be used where no intersecting road existed. "Other" (7) should be used for railroad tracks and other significant but otherwise unclassified intersections.

TYPE OF ROAD SURFACE (column 29)

This refers to the total road surface of the road on which the Case Vehicle was travelling.

"Asphalt" (1) also includes bituminous concrete. "Other" (7) should be used for oiled gravel, dirt (unimproved) and other unclassified types of roadway surfaces.

"More than one" (4) should be coded if more than one of the available choices (1, 2, 3, 7, or 9) is present amongst the various traffic lanes for that roadway. This can include both where a particular traffic lane changes from one type to another (a longitudinal transition), and where different lanes themselves are comprised of different surface types (a lateral transition, such as an asphalt outer lane having been added to supplement a concrete inner lane).

ROAD DEFECTS (column 30)

This question should be coded "yes" (1) only if that road defect was causative or in some other significant way involved in the accident. This can include potholes, pavement buckling, and raised or sunken sewers or railroad grade crossings.

Design deficiencies such as incorrect or inadequate banking, road configuration, and inadequate signing or sight distances will be coded "yes" (1) since there is no other mechanism for recording these data. Conditions directly associated with roadway construction should be coded in the next question.

CONSTRUCTION ZONE (column 31)

This should be coded "yes" (1) for conditions (sunken curbs, abrupt pavement level changes) or equipment (barriers, temporary signs) associated with roadway construction or repair.

ROAD ALIGNMENT, VERTICAL PLANE (column 32)

This question should be answered both with respect to the physical alignment, and with respect to possible visual obstructions. For instance, the Case Vehicle may have just crested a hill but be on a level spot at the first point of impact. This should be coded as "crest of hill" (2).

"Slope" (3) should be coded whenever a portion of the roadway of at least one hundred meters in length has a positive or negative incline of two percent or more.

ROAD ALIGNMENT, HORIZONTAL PLANE (column 33)

This should describe the roadway configuration, not the Case Vehicle's travel path. However, code "3" (T-shaped intersection) should be used only if the Case Vehicle was on (or turning onto) the truncated portion (the "dog leg").

As with the previous question, this one should be answered both with respect to the physical alignment, and with respect to possible visual obstructions. Furthermore, even if the Case Vehicle had left the curved portion and was on the straight portion of the roadway at the first point of damage or injury, if there was a loss of control attributable to an immediately prior curved portion (for instance), "curve" (2) should be coded.

SURFACE COVERING (columns 34-35)

"Spilled gravel" (61) can also include sand, loose dirt, or other type of material normally used for roadway construction which has been spilled or "tracked" onto the roadway surface, if it may have reduced the coefficient of friction. If such spilled material is not normally used for roadway construction (spilled grain, bricks, or other debris), then code "other" (71).

If a mixture of conditions existed, the most severe should be coded. A roadway which was wet with occasional patches of packed snow should be coded "32." If there were also occasional ice patches, then this question should be coded "41."

VISIBILITY LIMITATION (column 36)

"Cloudy/dark" (1) includes a low, heavy cloud cover. It should be coded only if this condition was possibly causative or severity increasing. This should not be coded because it was merely nighttime or overcast.

"Rain" (6) and "ice/snow" (8) should be coded only when the precipitation was heavy enough to cause a visibility problem.

VISIBILITY OBSTRUCTION (column 37)

"Vegetation" (3) also includes farm crops and other agricultural growths smaller than a "tree" (4).

"Vehicle in transport" (6) is any motor vehicle in a traffic way, whether or not it was moving. A non-moving vehicle in a legal parking area, even with a driver and with the engine running, is considered a "parked vehicle" (8). However, a bus at a bus stop is a "vehicle in transport" (6).

SPEED LIMIT (page GI-2, column 38)

Speed limit refers to the legal speed limit for the traffic way on which the Case Vehicle was travelling. Speed limit also applies to posted advisory speeds on curves and ramps.

For a driveway or some other unposted private road, code "0" unless other information is available.

PRECIPITATION (column 39)
RATE OF PRECIPITATION (column 40)

Code "9" both for "unknown if precipitating," and for "precipitating, type/rate unknown."

TEMPERATURE (column 41)

Code as appropriate. Be sure to distinguish Fahrenheit from Centigrade measurements.

CROSSWIND (column 42)

Code "9" both for "unknown if crosswind," and for "crosswind, strength unknown." Tailwinds and headwinds do not count as crosswinds.

Wind velocities of 0-8 km/h (0-5 miles/h) are considered "none" or calm (0), 8-23 km/h (6-14 miles/h) are considered "light" (1), and 24 km/h (15 miles/h) and greater are considered "strong" (2).

LIGHT CONDITIONS (column 43)

The "dark" codes (4, 5, 6) refer only to nighttime conditions. For a daytime accident with extraordinary darkness from clouds (etc.), code this question as "daylight" (1), but code the question on visibility limitation (page GI-1, column 36) as "cloudy/dark" if that was a causative or severity-increasing factor.

MECHANICAL MALFUNCTION**WAS THERE MENTION OF A MECHANICAL MALFUNCTION IN CASE VEHICLE** (column 44)

Any mention of mechanical malfunction should be coded here if it is recognized or suspected. If malfunction is recognized but did not contribute to accident causation or exacerbate crash conditions, code (2).

CRASH DETAILS (page GI-3)

Answer these questions on "Crash Details" without regard for when during the collision sequence these events may have occurred.

CASE VEHICLE AND OBJECT (column 45)

Code "yes" (1) only if such a contact produced damage or injury, even if the injury was not to a Case Vehicle occupant. This object contacted could include a pedestrian or an animal. If you are uncertain about damage or injury produced by this event, code "yes" (1) rather than lose the information.

If the only object contacted was the ground during a rollover sequence, then code this question "no" (0). If some other object (an embankment, culvert, protruding rock, roadside sign, etc.) was contacted during a rollover sequence, then code "yes" (1).

Curb contact should not be coded here unless it produced damage or injury.

CASE VEHICLE ROLLOVER (column 46)

Rollover is defined as any vehicle horizontal rotation of 90 degrees or more. If the Case Vehicle rolled over at any time during the collision sequence, code "yes" whether or not damage or injury resulted from the rollover. If the case vehicle rollover was the first event of the accident sequence, code "yes" (1) first event. Code (2) if the rollover was a subsequent event or (3) if you know it rolled over but are not sure of the event sequence. (The DA-2 page later in this form will reflect the same sequence you have coded here.) Rollover events are coded whether or not damage or injury resulted from the rollover here. ONLY rollovers which produce damage or injury are coded on DA-2.

If a trailer attached to the Case Vehicle rolled over, but the Case Vehicle itself did not, then code "no" (0). For all other questions on this page, a trailer being towed by the Case Vehicle is considered to be a part of that Case Vehicle, not as an "Other Vehicle."

CASE VEHICLE RAN OFF ROADWAY (column 47)

Code this question "yes" (1) if a ran-off-the-road course prior to initial impact contributed in any way to accident causation or severity, even if the Case Vehicle had returned to the road before that first damage- or injury- producing event occurred.

MOVING CASE VEHICLE AND CONTACTED MOVING VEHICLE (column 48)

Code "yes" (1) only if such a contact produced damage to either vehicle or injury to the occupants of either vehicle.

CASE VEHICLE AND CONTACTED STOPPED VEHICLE (column 49)

Code "yes" (1) only if such a contact produced damage to either vehicle or injury to the occupants of either vehicle.

STOPPED CASE VEHICLE AND CONTACTED VEHICLE (column 50)

Code "yes" (1) only if both of the following conditions were met:

- 1) Such a contact produced damage or injury; and
- 2) The initial collision sequence was still in progress.

The collision sequence came to a stop when all vehicles and objects involved came to a complete halt. Subsequent contact by another moving object or vehicle constituted a separate collision sequence, and should be ignored (unless that second collision sequence has been reported separately on an additional UMIVOR as another accident).

TOTAL NUMBER OF VEHICLES CONTACTED BY CASE VEHICLE IN CRASH (column 51)

Only those vehicles should be counted which caused damage to or were damaged by this Case Vehicle.

Enter "0" if this was a single-vehicle accident (no second vehicle was contacted).

Code "1" through "7" for the actual number of vehicles contacted. Enter "8" to indicate that eight or more were contacted, even if the exact number is unknown. Enter "unknown" (9) only if the total number is unknown, but it could have been less than eight.

ANY FIRE IN THIS CRASH (column 52)

This includes any fire in or on any vehicle or object involved in the collision sequence. Code "yes" (1) if the fire resulted from some aspect or impact of the collision sequence, even if that fire did not start until after the sequence itself had stopped (namely, all vehicles and objects involved had come to a complete halt).

However, exclude any fire which pre-existed the damage- or injury-producing collision sequence and did not spread to the Case Vehicle or cause injury to any occupant or pedestrian.

Also exclude a fire whose cause can be solely attributed to post-collision-sequence actions or impacts (for instance, was not fueled or otherwise exacerbated by collision-sequence-associated events). Examples might include the following:

- 1) a fire started by blowtorches used to cut away the vehicle during extrication;
- 2) a fire which first ignited during the towing operation;
- 3) a fire which occurred after the vehicle was in the impounding yard.

HIGHEST POLICE INJURY SEVERITY IN CRASH (column 53)

This applies to any vehicle involved in the crash, not just the case vehicle being reported.

Many police agencies use the KABC scale to denote injury severity. The following code values are used if this coding scheme (or one similar) is used by your police-investigating team: Code "0" if all occupants received no injuries. Code "1" (C by police) to denote possible injury. Code "2" (B by police) if a non-capacitating injury is the highest injury coded by police in this crash. Code "3"

(A) if the highest injury coded is an incapacitating injury. Code "4" (K) if anyone has been killed in this crash. Code "5" if narrative reveals someone is injured in this crash but police have not indicated severity. Code "6" if any occupant died prior to impact. Use "6" ONLY if there were no occupants coded K by police. Code "7" only if there were no fatalities and severity of injured is unknown. Code "9" if it is unknown if anyone is injured. NOTE: The fatal code (4) K, has precedence over all others.

DRIVER IMPAIRMENT

DRIVER ALCOHOL INVOLVEMENT (column 54)

Any police report indication of drinking, or any other evidence is sufficient for a "1" yes response. The driver need not have been tested for blood-alcohol content ("B.A.C."), or if tested need not have produced a result greater than "00."

DRIVER ALCOHOL B.A.C. (columns 55-56)

Observe the placement of the decimal point when recording the BAC.

If no chemical test was given, code "no test" (80), whether or not alcohol had been indicated (in the previous question) as being involved.

Code "00" if a test had been conducted, and the results showed no alcohol in the bloodstream.

Code "chemical test, no results" (90) if a chemical test was administered, but the results were not reported.

Code "unknown" (99) for "unknown if tested," or "unknown if alcohol involvement."

WAS THERE MENTION OF DRIVER IMPAIRMENT FOR CASE VEHICLE (column 57)

This includes but is not limited to alcohol impairment. However, actual impairment should have been noted (for instance, by the investigating police officer). One beer does not necessarily constitute impairment.

POST-CRASH DETAIL

MANNER CASE VEHICLE LEFT SCENE (column 58)

Use "9" unknown, if there was no indication the car was driven or towed from the scene.

ACCIDENT SCHEMATIC (page GI-4)

Complete this schematic, but use multiple positions for the Case Vehicle for each of its significant impacts. The final resting place of all vehicles, ejected occupants, and pedestrians should also be shown, if possible.

If the collision sequence was quite complex, analysts would appreciate being provided with additional Accident Schematics in attached materials.

Please describe the collision sequence as completely as possible in the "Accident Description" section. Attach additional written comments if needed.

The "Other Vehicle (B)" should be the same one that is documented on the "Other Vehicle" page.

The "Other Vehicle (C)" may be any other vehicle which played a significant role in the collision sequence. It need not have been responsible for any injury or damage causation in the collision sequence, and need not have been contacted by any other vehicle or object.

If more than one vehicle might qualify for being identified in the Accident Schematic as "Other Vehicle (C)," choose that one which had the greatest significance to the overall collision sequence.

Investigators may wish to denote more than one "other vehicle" (C, D, or possibly an E vehicle). Only data for the case vehicle and one "other vehicle" will be entered into the computer file. The Accident Investigator should clearly indicate which other vehicle is to be entered.

Module OV: OTHER VEHICLECRITERIA FOR SELECTION OF "OTHER VEHICLE"

If the Case Vehicle contacted no other vehicle during the collision sequence, leave this page entirely blank.

If the Case Vehicle did contact some other vehicle during the collision sequence, and if that contact produced damage to either vehicle or injury to one or more occupants of either vehicle, then this page should be completed in its entirety.

Complete this page even if the Other Vehicle would not itself qualify to be a Case Vehicle on a UMIVOR Report. This might include a truck, bus, train, or one of the other types of vehicles shown at the bottom of UMIVOR page OV-1.

The information from only one "Other Vehicle" page will be entered into the computer file. If more than one "other vehicle" qualifies under the above criterion, describe the one which caused the greatest damage to the Case Vehicle.

If the field investigator so desires, more than one "Other Vehicle" page may be completed and submitted, even though only one will be entered into the computer file. However, in such case, a clear indication must be made on the Form itself as to which of these reported "Other Vehicles" meets the criteria for selection discussed immediately above.

Such additional "Other Vehicle" pages could prove useful to an editor, or to a data analyst reviewing the "hard copy" of the file.

DESCRIPTION

MAKE; MODEL; NO. OF CYLINDERS OR ROTORS; CARGO (page OV-1)

Please record as appropriate, even though this information is not entered into the UMIVOR file.

VIN [Vehicle Identification Number] (columns 13-29)

The VIN contains the model designator (an alpha-numeric string) and production number (a numeric string) of the vehicle. Check for correct length and format with the Passenger Vehicle Identification Manual, or (if applicable) the Commercial Vehicle Identification Manual.¹

¹These are both published by the National Automobile Theft Bureau. For a complete listing of bibliographic materials, see the ANNOTATED BIBLIOGRAPHY.

Through the 1980 model year, GM, Chrysler, and AMC VIN's had thirteen characters, except for Cadillac which had only ten before 1971. Ford VIN's had eleven characters; the first and last script-type "F's" do not count and should not be recorded. Volkswagen VIN's had nine characters before 1970, and ten from then through 1980.

Starting with the 1981 model year, vehicles manufactured for sale in the U.S. must use a seventeen-character VIN format.

If a portion of the VIN cannot be determined, enter question marks ("??") in the corresponding boxes only. However, if none of the VIN is known, leave columns 13 through 29 entirely blank. Do not "invent" a VIN!

Delete all non-alphanumeric "special characters" (hyphens, slashes, etc.) except for the question marks described above. Left-justify the entry, and leave the unused trailing boxes (if any) blank.

Be sure to distinguish between the number "zero" (enter as "0") and the letter "O" (enter as "Ø"). Note that for the new seventeen-character format, the letters "I," "O," and "Q" are not valid entries.²

MANUFAC/BODY CODE (columns 30-34)

The Manufacturer/Body code consists of three elements. The first digit identifies the country of manufacture. The "unknown" code is "0."

The second element, comprised of the second and third digits, identifies the particular manufacturer within that country. The "unknown" code is "00."

The third element, comprised of the fourth and fifth digits, identifies the generic body style and type of the vehicle itself. (This same code is used for the Object/ Vehicle Contacted entry on page DA-2.) The "unknown" codes are as follows:

- 20 for "unknown automobile body"
- 30 for "unknown truck body"
- 00 for "unknown type of vehicle"

For further information on the specific codes, see Appendix: MANUFACTURER/BODY AND MAKE/MODEL CODES.

Prior to January 1, 1988, the Manufacturer/Body Code was called Make/Model Code. The terminology change is a result of an attempt on the part of the UMTRI editorial staff to make these designators consistent with Federal Coding Standards, namely NASS editing procedures.

²See Federal Motor Vehicle Safety Standard (FMVSS) 115.

MAKE/MODEL (columns 35-38)

This four-digit code was formerly called "Series Name Code". Once again, the term was changed to Make/Model to reflect the coding practices of the NASS and an attempt is being made to standardize these reference titles.

This additional code has been added to the "Other Vehicle" data to more clearly identify these vehicles for analyses. This code is used to identify the particular line (in some instances, the series within the line) for each manufacturer.

The Make/Model Code consists of two elements. The first two digits identify the manufacturer. The second two digits identify the specific series or line name within that particular manufacturer's production.

For both code elements, the "unknown" code is "99." The "known but no code assigned" code is "98". Editors will assign new codes prior to data entry as frequency is determined.

If the identity of the manufacturer is not known, no code can be assigned to that particular series or line. In such a case, enter "9999" in columns 35 through 38. If the identity of the manufacturer is known but it has no code assigned, the identity of the line or series may be either "unknown" or "known but not coded", (9899 or 9898). Editors will assign code values prior to data entry.

For more information, see Appendix: MANUFACTURER/BODY AND MAKE/MODEL CODES.

MODEL YEAR (columns 39-40)

Check this entry for consistency with the VIN. Record the last two digits of the year.

VEHICLE MASS (columns 41-46)

The shipping weight should be used; enter in kilograms. Do not use curb weight, loaded weight, or gross vehicle weight (GVW). Shipping weight is defined as the weight of the vehicle as built to production parts list, plus engine oil, coolant to capacity, and three gallons of gasoline, but less all optional equipment. For most cars and trucks, this shipping weight can be found in reference material such as the Red Book.³

Right-justify the entry and fill the leading blanks (if any) with zeroes. The "unknown" code is "999999."

³Published by the National Market Reports, Inc.

SEPARATE REPORT ... NUMBER (column 47)

If a separate UMIVOR Report has been completed, indicate here that Vehicle Number for this particular "Other Vehicle." For a vehicle reported on a UMIVOR Report, that number would appear in column 8 of page AD-1. For a large truck reported on a CPIR-B, or for a school bus reported on a CPIR-A, that "vehicle number" would appear on page 1, card 1, column 9.

If no such separate report has been completed, enter "0."

NUMBER OF OCCUPANTS (columns 48-49)

If the vehicle was not occupied at the time of impact, enter "00." If the number of occupants is unknown, enter "99." Enter "97" for "97 or more occupants." The code "98" should not be entered (it is reserved for a special program entry.)

Only persons actually in or on the vehicle should be counted. For instance, do not count a driver standing beside his stopped vehicle.

TRAVELING SPEED (columns 50-52)

Enter the speed (in kilometers per hour) of this Other Vehicle immediately prior to its first damage- or injury- producing impact, even if that impact was not with the Case Vehicle.

Code "000" if this other vehicle was stopped.

Code "995" if this other vehicle was just starting to move.

Code "996" if this Other Vehicle was backing up. Code "997" if the speed is unknown, but thought to have been safe for existing conditions and restrictions. Code "998" if the speed is unknown, but thought to have been excessive for the existing conditions and restrictions. Code "999" if the speed is unknown and no determination about speed is possible.

HIGHEST POLICE INJURY SEVERITY FOR THIS VEHICLE (Column 53)

Code as appropriate. Codes are the same as in the General Information Module but deal with this vehicle only.

VEHICLE TYPE (columns 54-55)

Enter as appropriate. Use "99" for "unknown."

WHEELBASE (Columns 56-58)

Indicate wheelbase in centimeters. Right justify with leading zeroes. Round decimals to nearest centimeter. Use "999" if the wheelbase is unknown.

OTHER VEHICLE DAMAGE (pictorial)

Indicate only the direct damage.

If the damage is only estimated (namely, actual physical inspection was not accomplished, vehicle repair had started prior to inspection, or the vehicle was not found), please indicate that on this page. If damage is only estimated, cite source of estimate (investigator, body repairman, etc.).

Additional types of vehicle pictorial diagrams can be found in the Appendix: OPTIONAL DAMAGE PICTORIALS. If one of the vehicle types shown there is more appropriate than the pictorial shown on this page, photocopy that page from the Appendix and include it (appropriately completed to show vehicle damage) with the UMIVOR Report.

Module VD: VEHICLE DESCRIPTION**MAKE; MODEL; NO. OF CYLINDERS OR ROTORS; CARGO (page VD-1)**

Please record as appropriate, even though this information is not entered into the UMIVOR file.

VIN [Vehicle Identification Number] (columns 13-29)

The VIN contains the model designator (an alpha-numeric string) and production number (a numeric string) of the vehicle. Check for correct length and format with the Passenger Vehicle Identification Manual, or (if applicable) the Commercial Vehicle Identification Manual.⁴

Through the 1980 model year, GM, Chrysler, and AMC VIN's had thirteen characters, except for Cadillac which had only ten before 1971. Ford VIN's had eleven characters; the first and last script-type "F's" do not count and should not be recorded. Volkswagen VIN's had nine characters before 1970, and ten from then through 1980.

Starting with the 1981 model year, vehicles manufactured for sale in the U.S. must use a seventeen-character VIN format.

If a portion of the VIN cannot be determined, enter question marks ("?") in the corresponding boxes only. However, if none of the VIN is known, leave columns 13 through 29 entirely blank. Do not "invent" a VIN!

Delete all non-alphanumeric "special characters" (hyphens, slashes, etc.) except for the question marks described above. Left-justify the entry, and leave the unused trailing boxes (if any) blank. Be sure to distinguish between the number "zero" (enter as "0") and the letter "O" (enter as "Ø"). Note that for the new seventeen-character format, the letters "I," "O," and "Q" are not valid entries.⁵

MANUFACTURER/BODY CODE (columns 30-34)

The Manufacturer/body Code consists of three elements. The first digit identifies the country of manufacture.

The second element, comprised of the second and third digits, identifies the particular manufacturer within that country.

The third element, comprised of the fourth and fifth digits, identifies the generic body style and type of the vehicle itself. New codes based on wheelbase

⁴These are both published by the National Automobile Theft Bureau. For a complete listing of bibliographic materials, see the ANNOTATED BIBLIOGRAPHY.

⁵See Federal Motor Vehicle Safety Standard (FMVSS) 115.

have been created for these last two digits. They are listed in table 6 in the Appendix in the MANUFAC/BODY AND MAKE/MODEL section.

For further information on the specific codes, see Appendix: MANUFAC/BODY AND MAKE/MODEL CODES.

MAKE/MODEL CODE (columns 35-38)

This is an additional code used to identify the particular line (in some instances, the series within a line) for each manufacturer.

The Make/Model Code consists of two elements. The first two digits identify the manufacturer. The second two digits identify the specific series or line name within that particular manufacturer's production.

For both code elements, the "unknown" code is "99." The "known but no code assigned" code is "98." (Editors will assign new codes prior to data entry.)

If the identity of the manufacturer is not known, no code can be assigned to that particular series or line. In such a case, enter "9999" in columns 35 through 38. If the identity of the manufacturer is known but it has no code assigned, the identity of the line or series may be either "unknown" or "known but not coded" (9899 or 9898 respectively).

For more information, see Appendix: MANUFACTURER/BODY CODE AND MAKE/MODEL CODES.

MODEL YEAR (columns 39-40)

Check this entry for consistency with the VIN. Record the last two digits of the year, if they fall in the range of "00" to "98." The "unknown" code is "99."

VEHICLE MASS (columns 41-44)

The shipping weight should be used; enter in kilograms. Do not use curb weight, loaded weight, or gross vehicle weight (GVW). Shipping weight is defined as the weight of the vehicle as built to production parts list, plus engine oil, coolant to capacity, and three gallons of gasoline, but less all optional equipment. For most cars and trucks, this shipping weight can be found in the Red Book.⁶

Right-justify the entry and fill the leading blanks (if any) with zeroes. The "unknown" code is "9999."

⁶Published by the National Market Reports, Inc.

ODOMETER READING (columns 45-50)

Enter in kilometers. If unknown, enter "999999." Enter "999998" for "999998 or more." If the odometer was disconnected or broken prior to the collision, enter "unknown" (999999). Investigators are unable to determine mileage on new vehicles equipped with electronic odometers. In these cases, use "888888" as the code for this designation.

NUMBER OF OCCUPANTS (columns 51-52)

If the vehicle was not occupied at the time of impact, enter "00." If the number of occupants is unknown, enter "99."

Only persons actually in or on the vehicle should be counted. For instance, do not count a driver standing beside his stopped vehicle.

TRAVELING SPEED (columns 53-55)

Enter the speed (in kilometers per hour) of the Case Vehicle immediately prior to its first damage- or injury- producing impact, whether or not that impact was with the identified "Other Vehicle" (page OV-1).

Code "000" if the vehicle was parked or stopped.

Code "995" if the vehicle was just starting up.

Code "996" if the Case Vehicle was backing up.

Code "997" if the speed is unknown, but thought to have been safe for existing conditions and restrictions.

Code "998" if the speed is unknown, but thought to have been excessive for the existing conditions and restrictions.

Code "999" if the speed is unknown and no determination about speed is possible.

BODY TYPE (columns 56-57)

A car with any type of upper B-pillar, however thin, is defined for these purposes as a (two-door) coupe or a (two- or four-door) sedan. This upper B-pillar can be made of fiberglass and need not be structurally substantive, just some form of body- or sheet-metal-member other than movable glass.

Note that some cars called "hardtops" or "pillared hardtops" by some manufacturers are, by this definition, actually sedans or coupes.

A Corvette without a removable hardtop, or a 1970 or later Firebird or Camaro is considered to be a "coupe" (12), but with no C-pillars.

A "pickup car" (such as a Ranchero or an El Camino) is coded as a station wagon (15).

A car with a soft shell or a removable hard shell is coded as a convertible (16). A removable hardtop is one that can be removed without tools. Removable solid roof sections that were bolted on at the factory constitute a standard roof. A car with a sun roof should also be coded as a standard car. (Note that roof types are coded separately, on page VD-2, column 71.)

"Small utility" (21) can be distinguished from "large utility" (22) by wheelbase: "small utility" vehicles have a wheelbase of less than 107 inches.

STOLEN VEHICLE (column 58)

Record as appropriate. In border-line cases (vehicle driven without owner's permission, for instance), use the determination of the police department which filed the accident report.

BODY STRUCTURE (column 59)

A vehicle with a unitized body (2) cannot have a body-mount separation. Jeeps with tub body are coded (7) Other. Check for consistency with page ED-3 (column 34) and page ED-5 (column 54).

TRANSMISSION (column 60)

Code "none" (0) for a vehicle without any transmission (for instance, an electrically powered or steam-driven vehicle).

LOCATION OF TRANSMISSION SELECTOR LEVER (column 61)

If a "console" location is coded (2), check for consistent entry on page ID-1, column 50.

If the vehicle has no transmission (see previous question), it still probably has some kind of control to choose between forward- and reverse-running commands (for instance, a panel switch of some kind). Code "other" (7) and explain.

STEERING (column 62)

Code as appropriate.

BRAKES (column 63)

Code as appropriate. Any form of braking assistance (vacuum powered, compressor assisted, electrically modulated, etc.) automatically derived from a vehicular power source constitutes a "power brake" system (1).

TYPE OF BRAKES (page VD-2, column 64)

Code "unknown" (9) for "unknown if disc brakes," and for "known to be disc brakes, but unknown if on all wheels."

BRAKE ANTI-LOCK DEVICE (column 65)

"Anti-lock devices" do not include conventional anti-slip differentials ("posi-traction," etc.).

Code (7) if equipped but type unknown.

Code "unknown" (9) for "unknown if installed," and for "known to be installed, unknown if on all four wheels."

Note that this question pertains only to device installation, not to its operability.

AIR CONDITIONING IN VEHICLE (column 66)

This applies specifically to an engine-powered air-conditioner. This device can be either original equipment or "after market."

TYPE OF DRIVE (column 67)

"Four wheel" (3) should be coded when both rear-wheel- and front-wheel-drive capabilities exist, even if the total number of driven wheels is other than four. Do not code if the four driven wheels are solely on the front or on the rear.

If the vehicle is known to have front-wheel or rear-wheel drive, but is not known whether or not to also have four-wheel drive, code only the known drive method. Code "unknown" (9) only when none of the drive-capability is known.

DUAL REAR WHEELS (column 68)

This refers to dual-wheel configurations on both ends of the rear axle.

This should not be coded for a dual-rear-axle ("tag axle") configuration, unless one or more of those rear axles also have dual wheels on both ends. However, that kind of vehicle probably would not qualify to be coded on a UMIVOR report.

ORIGINAL TYPE OF RESTRAINT SYSTEM (column 69)

This question pertains to the original, permanently installed type of restraint system. Disregard after-market equipment or any removal, modification, or disablement of original equipment.

A particular Case Vehicle may be equipped with more than one type of restraint system. Enter the response based on the following prioritization:

- 1) If the vehicle is equipped with an air bag for any seating position, code "air bag" (3).
- 2) If the vehicle is not equipped with any air bag, but is equipped with some form of passive belt system for any front-seat position, then code "passive belt" (2).
- 3) If the vehicle is equipped with neither an air bag nor a front-seat passive belt, but is equipped with some other form of passive-restraint system, code "other" (7) and describe.
- 4) If none of the above is appropriate, choose from amongst any of the remaining codes (1, 8, and 9).

EQUIPPED WITH ROLL BAR (column 70)

This can include either original or "after-market" equipment.

TYPE OF ROOF (column 71)

A "convertible" (6 or 7) has a roof whose removal leaves substantially no roof side rails. (Check response in columns 56-57 on page VD-1 for consistency.)

A "T-top roof" (2 or 3) may leave a portion of the roof side rail structure in place behind the B pillar upon removal.

A "sun roof" leaves the entirety of the roof side rails in place upon removal. "Sun roof" (4 or 5) may also be coded if the opening is merely a vent or a window (namely, is not entirely removable).

A "rag-top" roof (for instance, on some small utility vehicles) should be coded here as "solid" (1) if it has a metal-rod support structure around its perimeter.

"Other", (8) would include roofs such as a hard-top roof on a jeep.

WHEELBASE (Columns 72-74)

Indicate wheelbase in centimeters. Right justify with leading zeroes. Round decimals to nearest centimeter. Use "999" if the wheelbase is unknown.

PLASTIC ANTI-LACERATIVE INNER LAYER GLASS EQUIPPED (Column 75)

Code as appropriate. Can include original or "after-market" equipment.

VEHICULAR DAMAGE DIAGRAM (page VD-3)

Indicate only direct damage.

If the damage is only estimated (namely, actual physical inspection was not accomplished, and vehicle repair had started, or the vehicle was not found), please indicate that on this page. If damage is only estimated, cite source of estimate (investigator, body repairman, etc.).

Additional types of vehicle pictorial diagrams can be found in the Appendix: OPTIONAL DAMAGE PICTORIALS. If one of the vehicle types shown there is more appropriate than the pictorial shown on this page, photocopy that page from the Appendix and include it (appropriately completed to show vehicle damage) with the UMIVOR Report.

Module DA: **DAMAGE****"PRIMARY" IMPACT** (page DA-1, top half of the page)

If the Case Vehicle suffered damage from more than one impact, the one which should be described is that one in which the greatest energy was dissipated. If a clear distinction can not be drawn using that criterion, then choose the "primary" impact on the basis of which one caused the greatest intrusion into the passenger compartment.

EVENT NUMBER (column 13)

The "event number" coded here should be checked for consistency with the collision sequence described on the following page (DA-2). The "not applicable" code (8) should not be used in column 13.

IMPACT SPEED (columns 14-16, 35-37)

Enter in estimated kilometers per hour. If a "CRASH"⁷ run has produced reasonable results, use those figures (if applicable). (Note, however, that this question asks for impact speed, not "delta V" or change in velocity as a result of this impact.)

The "not applicable" code (998) should not be used for the Case Vehicle in columns 14 through 16. If the "primary impact" was between the Case Vehicle and an object, code "not applicable" for the entirety of the "contacted vehicle" entries (columns 35 through 55):

998/8/998/98-0000-0/98-0000-0.

(IMPACT SPEED) ESTIMATED BY (columns 17 and 38)

If an impact speed has been coded, then a source for that information must be identified. If the investigator himself cannot estimate the impact speed for one or both vehicles, he should code "unknown" (999) in columns 14 through 16 and/or 35 through 37 as appropriate, and then code column 17 and/or 38 respectively as "investigator" (1).

If a subsequent editor finds any entry for impact speed (including "unknown" [999]) but no attribution of source for this information, he should enter "investigator" (1) in column 17 and/or 38, as appropriate.

If the editor finds that an impact-speed response has been omitted altogether, then he should enter an "unknown" (999) in columns 14 through 16 and/or 35 through 37 as appropriate, and identify the source (column 17 and/or

⁷Calspan Reconstruction of Accident Speeds on the Highway, a computer simulation program for collision reconstruction. See the ANNOTATED BIBLIOGRAPHY.

38 as appropriate) as "editor" (9). The "editor" (9) code in columns 17 and 38 may be used only in the circumstance just described.

The "not applicable" code (8) should not be used for the Case Vehicle (column 17). It should also not be used in column 38 if there was any "contacted vehicle."

CRUSH (columns 18-20, 39-41)

Enter actual crush (not the induced damage) in centimeters. Crush should be measured along the same axis as the CDC "Extent Code." For compound (multiple-axis) CDC's (discussed on the next page), enter the greater measure.

The "not applicable" code (998) should not be used for the Case Vehicle (columns 18 through 20). It should also not be used in columns 39 through 41 if there was any "contacted vehicle."

CDC (columns 21-27, 28-34, 42-48, 49-55)

The CDC (Collision Deformation Classification)⁸ consists of seven alphanumeric characters which describe the direction, location, size of area, and extent of deformation. It is an indicator of direct damage only, and should not be used to represent indirect or induced damage.

The "unknown" and "no damage" codes are "99-0000-0." The "not applicable" code is "98-0000-0." The first CDC for the Case Vehicle (columns 21 through 27) must be a finite entry or "unknown" (99-0000-0); the "not applicable" code (98-0000-0) must not be used in columns 21 through 27.

If the contacted vehicle" was a large truck, enter the "Truck Deformation Classification ("TDC") code.⁹ If the contacted vehicle was some other type which cannot be assigned either a CDC or a TDC, enter the "unknown" code (99-0000-0).

The "CDC #2" entry (columns 28 through 34 for the Case Vehicle, columns 49 through 55 for the Contacted Vehicle) is only for compound, "conversion"-type (multiple-axis) CDC's, a special-case application described in detail in SAE J224 MAR80. (Column 26 [for the Case Vehicle] or column 47 [for the Contacted Vehicle] would have a "K" entered for the "CDC Damage Distribution" code.) Any other damage from a particular impact should be represented by a single CDC.

⁸The CDC (Collision Deformation Classification) is described in "SAE Recommended Practice J224 MAR80" in the SAE Handbook.

⁹The Truck Deformation Classification is described in "SAE Recommended Practice J1301" in the SAE Handbook. It applies only to large trucks. A light truck which could qualify to be reported as a Case Vehicle on a UMIVOR Report should be assigned a Deformation Classification in accordance with the CDC standards in "SAE Recommended Practice J224 MAR80" instead.

In the absence of a qualifying "compound CDC," enter the "not applicable" code (98-0000-0) in columns 28 through 34 and/or 49 through 55. An exception to this is when the first CDC for either vehicle is unknown (99-0000-0), in which case enter "unknown" (99-0000-0) also for "CDC #2" for that vehicle. In a two-vehicle impact, one vehicle may have a compound CDC and the other may have just a single CDC for that particular impact.

Other General Comments about the "Primary" Damage Entry.

"Not applicable" codes should not be used for the Case Vehicle entries, except (usually) for the "CDC #2" in the absence of a qualifying compound (multiple-axis) impact.

If the Case Vehicle primary impact was not with another vehicle, then all of the codes for the "contacted vehicle" should be "not applicable" (998/8/998/98-0000-0/98-0000-0 in columns 35 through 55).

If that primary contact was with another vehicle, then none of those entries should be "not applicable," except again (usually) for the "CDC #2" entry (columns 49 through 55).

"SECONDARY" IMPACT (page DA-1, bottom half of page)

If the Case Vehicle experienced only one damage- or injury-producing impact, enter "not applicable" (8) in column 13, and leave the remainder of the lower portion of this page entirely blank, even though the "contacted vehicle" referred to in the "primary damage" section in the upper portion of this page DA-1 may have had a secondary impact with a third vehicle or with some object.

If the Case Vehicle experienced more than one damage- or injury-producing impact, the "contacted vehicle" (if appropriate) to be described here need not be the same one which was referred to in the "primary damage" section above, nor the one documented on the "Other Vehicle" page (OV-1).

If the Case Vehicle suffered damage from more than two impacts, the next most significant one to describe here should be chosen using the same criteria as were used for choosing the primary impact: the one with the next greatest energy dissipation, or if that cannot be determined, the one with the next greatest passenger compartment intrusion.

MAXIMUM SHEET METAL CRUSH (page DA-2, columns 13-30)

These measurements (in centimeters) should represent the distance in from the original contour, not the total extent of crush from the outer-most (boxed) profile. If the particular side suffered multiple impacts, code the greatest amount of crush. Measurements should always be made on a horizontal (or vertical, as appropriate) line relative to the vehicle's original contour and stance,

on the same plane used for the CDC "Extent Code" measurement. Use "000" if the area had no crush and use "999" if the amount of specific crush is unknown.

CHRONOLOGICAL SEQUENCE (column 31)

This refers to the chronology of the collision sequence itself. Note that the sequence came to a stop when all vehicles and objects involved came to a complete halt. Subsequent contact by another moving object or vehicle constitutes a separate collision sequence, and should not be reported on this UMIVOR. Answer "no" (0) or "yes" (1) as is applicable. In either case, continue with responses in the next section.

EVENT NUMBER (Event Description, general comments)

For any line which has an entry, all five elements on that line must be completed. Lines after the last "event" entry should be left entirely blank.

Please note that the "event number" associated with the particular impact on this page is the same number that should be recorded on the previous page (column 13). Other references in the UMIVOR to this "event number" are on pages CR-1, CR-2, FL-1, IT-3, and (if needed) IT-4.

Only damage or injury-producing events are recorded in this section.

IMPACT LOCATION (single column)

If neither the Case Vehicle nor the contacted vehicle or object was entirely off the roadway at the point of the first impact, then code "on roadway" (1), even if the respective first surfaces to contact were themselves off the roadway. Use specific other codes 2-6 if applicable.

IMPACT CONFIGURATION (two columns)

For a compound impact (including a multiple-axis impact which calls for two CDC's to be assigned [see SAE J224 MAR80]), enter the impact configuration for the first contact, even if it was not the more extensive.

However, any impact during which more than one object or vehicle was contacted should instead be classified as multiple impacts. An exception would be multiple objects responding to the impact as if they were a single object. (An example might include three small trees growing together in a tight [two-foot diameter] cluster.)

Code "58" can be distinguished from "59" in that the former is for a known but otherwise unclassified vehicle-to-vehicle configuration, whereas the latter is for some unknown vehicle-to-vehicle configuration.

The axis of measurement for a rollover (codes "61," "62," or "69") can be any horizontal line through the Case Vehicle's original stance.

Code "impact type unknown" (99) only if it is unknown if the impact was with another vehicle or with an object.

OBJECT/VEHICLE CONTACTED (two columns)

Note that the "passenger vehicle" designation (codes "01" through "20") should be the same as the last two digits of that contacted vehicle's Manufacturer/Body Code.

A motorized vehicle which is also capable of being human-powered (a pedalcycle, a motorized bicycle, etc.) should be coded as "71" instead of as a type of motorcycle ("50" through "57").

Module CR: CRASH RECONSTRUCTION*DATA FORMATTED FOR "CRASH"¹⁰ RECONSTRUCTION* (page CR-1)

Complete this information whether or not CRASH will be or has been run by the Investigating Team.

Use a separate line for the measurements for each "event number." Be sure that these "event numbers" correspond to the "events" list on page DA-2.

The various "events" listed for the contacted vehicle (lower portion of page CR-1) need not all be for the same "other vehicle."

All non-zero entries in the "D" columns should be signed as either positive or negative.

RESULTS FROM "CRASH" RECONSTRUCTION (page CR-2)

The "primary" and "secondary" impacts coded here should correspond to the same "primary" and "secondary" impacts described on page DA-1.

If the Case Vehicle experienced only one impact, the columns for the secondary impact (columns 47-65) should be left entirely blank. However, the columns for the primary impact (13-46) should always be filled out. Columns 13-46 must contain no blanks.

For the columns concerning "delta V" ("change in velocity": columns 14-24, 32-42, 48-58, and 66-76) and energy dissipation (columns 25-28, 43-46, 54-62, and 77-80), the "unknown" entry is all "9's." For those of these columns pertaining just to the "Contacted Vehicle," the "not applicable" code is all "8's" (signifying that this Case Vehicle impact was with an object, not with another vehicle). The "not applicable" code (8) should not be used for any of the "Case Vehicle" entries.

For the longitudinal and lateral components of "delta V" (which apply only to vehicles, not to objects), any finite entry (namely, not "unknown" [9999] or "not applicable" [8888]) other than "none" (0000) must be signed as either positive or negative.

¹⁰Calspan Reconstruction of Accident Speeds on the Highway, a computer simulation program for collision reconstruction. See the ANNOTATED BIBLIOGRAPHY.

Module WT: WHEELS AND TIRES

If there are more than four wheels and tires, the responses on this page should be for those which are used for the primary or outer-most steering and power delivery. However, if a non-coded wheel and/or tire was significantly involved in causing, extending, or exacerbating the collision sequence, describe the circumstances on an attached page.

For a three-wheeled vehicle, code a center-mounted wheel and tire as being on the left side.

If the Case Vehicle lacked a wheel and/or tire in a particular position (for instance, the vehicle was parked and the tire was being changed at the time of that vehicle's first damage- or injury-producing impact), code "not applicable" (8) in the respective columns.

WHEELS DAMAGED (page WT-1, columns 13-16)

Only damage to the wheel or wheel rim (but not to the tire) should be coded. The "not applicable" code is "8."

TIRE TREAD TYPE (columns 17-20)

Code as appropriate. "Off-road" treads should be coded as "snow" (2) unless the tires are unsuitable for sustained, high-speed, on-highway driving, in which case code as "other" (7).

Code "slicks" (3) only for a tire specifically designed and intended for use solely on a race track. A conventional tire which is worn "bald" should not be coded as a "slick."

A truck tire should be coded in this question the same as a passenger-car tire.

The "not applicable" code is "8."

CARCASS CONSTRUCTION (columns 21-24)

Code as appropriate. The "not applicable" code (8) should be used only if there was no tire at the respective location.

SIZE (columns 25-64)

Enter the alphanumeric industry size code. If a portion of the size code is not known or is indistinguishable, enter question marks ("?'s") in the corresponding spaces. If size designation doesn't fit in columns (for example: some oversize off-road vehicles) write complete number beyond field.

Delete all non-alphanumeric characters other than these question marks. Left-justify and collapse the entry, leaving trailing blanks as necessary.

Examples: G7814, P18575R14. Distinguish between the number "zero" (enter a "0") and the letter "O" (enter as "Ø").

Code "not applicable" (9999999998) only if there is no tire in the respective position.

BRAND (no column entry)

Please complete, even though this is not entered into the file. If there is no tire in the respective position, write in "no tire," and indicate in the margin the reason (tire being changed, three-wheeled vehicle, etc.).

Module FT: **FUEL AND FUEL TANKS****TYPE OF PROPULSIVE FUEL** (page FT-1, column 13)

Code as appropriate. Code "other" (7) for "electricity/battery" and for "alcohol (alone)." For gasohol, code "gasoline" (1).

MAIN TANK LOCATION (columns 14-16)**MAIN FILLER CAP LOCATION** (columns 17-19)**MAIN TANK MATERIAL** (column 20)

Complete as appropriate. If the Case Vehicle has no frame, answer the "vertical" questions (columns 16, 19, 24, and 27) with reference to where the frame would normally be located.

For vehicles using electric power only, enter "8's." (For the questions on this page, the storage batteries for an electrically-driven vehicle are not considered to be "tanks.") Otherwise, "8's" should not be used in columns 14 through 20.

AUXILIARY TANK TYPE (column 21)

Distinguish if possible between original-equipment-manufactured ("OEM," code as "1") and after-market ("2") tanks. If there is more than one auxiliary fuel tank, complete columns 21 through 28 for the largest one.

Code "9" both for "unknown if equipped," and for "equipped, type unknown."

AUXILIARY TANK LOCATION (columns 22-24)**AUXILIARY FILLER CAP LOCATION** (columns 25-27)**AUXILIARY TANK MATERIAL** (column 28)

Complete as appropriate. No "8's" should be entered in columns 21 through 28 unless there is no auxiliary tank, in which case all entries should be "8's."

Module FL: **FUEL LEAKAGE**

For purposes of this page only (except as otherwise noted), the battery on an electrically driven vehicle is considered to be a "fuel tank."

DID FUEL LEAKAGE RESULT FROM A CRASH EVENT

(page FL-1, column 13)

If the answer is "no" (0), or there is no apparent fuel leakage then this is the only response which should be coded on this page.

If some form of fuel leakage resulted from a crash event, then code "yes" (1) and complete as many lines as appropriate. Leave the remaining lines entirely blank. Leave no blank on any line which otherwise has an entry.

LEAKING COMPONENT (overall column I)

Complete as appropriate. On an electrically-driven vehicle, code battery leakage as if from the main fuel tank.

COMPONENT SOURCE (overall column II)

Complete as appropriate. For an electrically-driven vehicle, the main "drive" battery constitutes an original-equipment device, even though the battery itself may not be the original equipment.

TYPE OF DAMAGE (overall column III)**SEVERITY OF DAMAGE** (overall column IV)

Code as appropriate. If leakage did not result from damage, but rather to spillage from tipping (etc.), code "none" (0) both in column III and in column IV. This applies both to electrically-driven and to conventional combustion-engine vehicles.

LOCATION OF LEAK (overall column V)

Code as appropriate.

EVENT NUMBER (final overall column)

Use the "event number" here which corresponds to the occurrence described on page DA-2.

Module FR: **FIRE****WAS THERE FIRE IN OR ON CASE VEHICLE** (page FR-1, column 13)

If there was no fire, code "no" (0) and leave the remainder of this page entirely blank.

Answer "yes" (1) for any fire which resulted from or was exacerbated by some impact or aspect (for instance, fuel leakage) of the collision sequence, even if that fire did not start until after the sequence itself had stopped (namely, all vehicles and objects involved had come to a complete halt).

If the fire can be attributed solely to post-collision-sequence actions or impacts (for instance, was not fueled by collision-sequence-associated events), answer "no" (0) and leave the remainder of the page entirely blank. Examples include the following:

- 1) a fire started by blow torches used to cut away the vehicle during occupant extrication;
- 2) a fire which first ignited during the towing operation;
- 3) a fire which occurred after the vehicle was in the impounding yard.

In such cases, complete the "notes" and narrative section on the bottom portion of this page, especially addressing why any fire damage showing on the accompanying slides is not attributable to the collision sequence.

In all other portions of the UMIVOR report, damage which can be attributed to some impact-related portion of the collision sequence (other than the fire) should be coded as usual. Damage which can be attributed solely to the occurrence of the fire should be ignored. Damage which may or may not have been fire related, but which could possibly be attributed to some portion of the impact-related events, should be coded as "unknown."

Damage which is not impact related should be ignored.

Injuries which are attributable to a collision-sequence-related fire should always be coded. If the fire causing that injury was not related to a collision sequence, then the injury should not be coded on page IC-2.

DID FIRE START IN CASE VEHICLE (column 14)

This includes any fire which started with objects or fluids originally in or on the Case Vehicle, and which were still attached or immediately adjacent to it at the time of ignition. An example would be where the Case Vehicle's fuel spilled onto its hood or on the ground underneath it. Another example would be where the fire started from heat radiated from the catalytic muffler, setting ablaze dry grass underneath the vehicle.

FLAME PROPAGATION RATE (column 15)

Code as appropriate. "Rapid/explosive" propagation (1) can be distinguished as requiring immediate and rapid occupant evacuation of the vehicle.

SEVERITY OF FIRE DAMAGE (column 16)

This question pertains to the extent of total fire damage, not to the rate of consumption. Even a slowly smouldering fire can eventually totally destroy an entire vehicle.

"Minor" fire damage (code as "1") should be easily repairable or replaceable (for instance, limited to a seat cushion or to floor carpeting).

"Severe" fire damage (code as "3") includes any which caused major structural-component damage, for instance to the metal or fiberglass structural components around the passenger compartment.

"Moderate" fire damage (code as "2") includes that which is more extensive than to be easily repaired or replaced, but exclusive of any which caused major structural-component damage. An example might include an engine compartment fire which did not spread to the passenger compartment.

DID AN INJURY TO CASE VEHICLE OCCUPANT RESULT FROM FIRE IN OR ON CASE VEHICLE (column 17)

"Occupancy" status is determined at the point of initiation of the collision sequence.

This question includes only those fires to which the occupant was involuntarily exposed. If the injury was sustained when the former occupant reached back into the burning Case Vehicle to retrieve an object or in an attempt to assist another occupant to escape, he is considered to have voluntarily exposed himself, and such an injury should not be coded here, nor in the later Occupant Section (page IC-2).

Module ED: EXTERIOR DAMAGE**HOOD PERFORMANCE** (page ED-1)**HOOD LATCH(ES)** (columns 13-15)

The hood can include a front trunk cover, such as might be found on a rear-engine vehicle. For a forward-engine van without a front exterior hood, all questions about the hood should be coded as "not applicable" (8).

These questions ask if the hood latch is inoperable or released. Disregard mere sheet-metal deformation that prevents opening of the hood. A latch cannot be both jammed and released. If there are two latches, one of which released but the other one of which jammed, the latches should be coded as having jammed (column 15 = 1) but not released (column 13 = 0).

HOOD HINGES (columns 16-19)

If there is no damage, then there can be no separation. Only complete separation should be coded.

HOOD REMAINED ON VEHICLE (column 20)

If the hood latch(es) had released and both hinges had separated completely, but the hood remained in place due to sheet-metal deformation, the hood is considered to have remained on the vehicle.

REAR EDGE OF HOOD (columns 21-23)

If the rear edge of the hood moved above its normal pre-crash position, it is considered "elevated." This may be a difficult distinction to make on a vehicle which has no cover plate between the rear edge of the hood and the windshield.

Windshield contact by the rear edge of the hood need not have been damage producing. If the rear edge of the hood touched any part of the windshield at any time during the collision sequence, even if it pulled away again or did not cause any damage, then contact should be coded "yes" ("1" in column 22).

On a vehicle without a cover plate between the rear edge of the hood and the windshield, the rear edge need not have been "elevated" to make this contact.

If the hood tore the windshield interlayer or caused a break in it, the hood is considered to have penetrated the windshield. Check for consistency with the windshield breakage inquiry on page ED-6, column 71. If the hood physically penetrated through the windshield, then this should also be noted as an intrusion on pages IT-3 or IT-4.

The "elevated" question (column 21) should be coded "not applicable" (8) only if there was no front hood. The "contacted" question (column 22) should be coded "not applicable" (8) only if there was no windshield or no front hood. The "penetration" question (column 23) should be coded "not applicable" (8) only if there was no hood-to-windshield contact, no windshield, or no front hood.

HOOD LATCH LOCATION (column 24)

Code as applicable. Code "not applicable" (8) only if there was no hood.

ENGINE OR TRANSMISSION MOUNT

SEPARATION (column 25)

This refers to all engine and transmission mounts, but includes only complete separations. Partial separations and cracks do not qualify.

STEERING COLUMN FLEXIBLE COUPLING

FLEXIBLE COUPLING TYPE (column 26)

The flexible coupling may be composed of a flexible fabric or cable, or a collapsible universal joint or pot joint. Although usually located in the engine compartment, a portion or the entirety of this coupling may instead be in the passenger compartment.

All GM cars (starting with model year 1967) which have steering column energy absorbing devices ("EAD's" - see page SC-2, columns 23 and 24) are also equipped with these steering column flexible couplings. Most other vehicles are also equipped with them, whether or not they also have telescoping units or steering column EAD's.

COUPLING DAMAGED (column 27)

COUPLING SEPARATED (column 28)

If the Case Vehicle has no steering column flexible coupling, enter "not applicable" (8) in these two columns. A separation cannot occur ("1" in column 28) unless the unit was also damaged ("1" in column 27).

ENGINE COMPARTMENT TELESCOPING UNIT

TYPE OF UNIT (columns 29-30)

(MEASUREMENT) DIFFERENCE (columns 31-33)

To insure proper coding and measurement of the telescoping unit, the type and original length should be checked with the M.V.M.A. Accident Investigator's Manual¹¹ for the appropriate model year.

¹¹For full bibliographic reference, see the ANNOTATED BIBLIOGRAPHY.

The measurement tolerance for the telescoping unit is 15 mm. If there is a difference between the original and the telescoped or extended length of the unit of 15 mm or less, then enter "000" in columns 31 through 33.

If a U-joint or flexible cable serves both as the steering column flexible coupling and as the engine compartment telescoping unit, code it only as the former. In such cases, enter "00" in columns 29 and 30, and "998" in columns 31 through 33. This would include the Ford "mini-column," for instance.

As a general rule, all GM cars with a gear box in front of the forward axle have telescoping units, whereas those with the gear box behind that axle do not.

Enter "991" if the telescoping unit was not measured, but a visual inspection or other impact-related information suggests that there was probably no compression. If there was apparent or suggested compression, but the exact amount could not be measured (for instance, the unit was inaccessible due to other impact damage, etc.), enter "992." If the device was extended, enter "993."

If measurement of the telescoping unit was not possible (for instance, the unit was inaccessible due to impact damage), and compression may have occurred but this cannot be determined for sure, enter "997." If no measurement was made for some other reason, and no clear suggestion is possible about compression, enter "unknown" (999).

LEFT-SIDE BODY MOUNT (Page ED-3)

DID BODY MOUNT SEPARATE? (column 34)

This should be coded "yes" (1) only for a complete separation. Note that vehicles with a unitized body structure do not have body mounts. Check for consistency with the body structure entered in column 59 on page VD-1.

LEFT PILLARS

PILLARS SEPARATED COMPLETELY (columns 35-42)

*** (Circle any response where damage other than complete separation has occurred.) ***

Only a complete separation should be coded "yes" (1). Partial separation, cracking, or other damage short of a complete separation does not qualify. If, however, damage has occurred without complete separation, circle that response which has been damaged. This will provide information to analysts who search hard-copy reports.

The lower portion of the pillar starts at the top of the belt line and extends downward to and including its attachment to the lower side rail. The upper portion starts immediately above the belt line and extends upward to and

including its attachment to the roof side rail. If a complete separation occurs right at the belt line, both upper and lower portions should be coded as separated.

A vehicle coded as a "hardtop" ("11" or "13" in columns 56 and 57 on page VD-1) should have no upper B-pillars.

A vehicle coded as a "convertible" ("16" in columns 56 and 57 on page VD-1) usually has no upper B- or C-pillars. (This also applies to those multi-purpose passenger vehicles [MPV's] which have a removable roof or no roof at all.) The structure associated solely with the convertible top itself does not constitute an upper B- or C-pillar assembly.

A passenger vehicle has a lower C-pillar only if and where there is a side rear door with a latch (unless it has a tailgate or a hatchback, as described below). For example, a van with a side rear door only on the right side has upper and lower A-, B-, and D-pillars on the left side, but no upper or lower left C-pillars, even though it does have upper and lower right C-pillars.

Most conventional passenger cars do not have D-pillars. Exceptions include four-door models with a window behind the side rear door (for instance, some hatchbacks, sedans with "opera windows," and station wagons). In those cases, the vehicle has an upper D-pillar, but no lower D-pillar unless there is an associated door and latch (following the same criteria as discussed for lower C-pillars in the previous paragraph), or unless there is a tailgate or hatchback (see below).

Any vehicle with a tailgate enclosing the rear of the passenger compartment has upper and lower rear pillars (C-pillars, or D-pillars if there are already C-pillars forward of the rear pillars). (Note that this excludes pickup trucks.) A "hatchback" also has at least rear upper pillars, plus rear lower pillars if the passenger compartment at the hatchback opening extends below the belt line.

Except as specified above, assign alphabetical designations to the pillars sequentially. For instance, if the vehicle has no C-pillars, then it can have no D-pillars. However (as noted above), a van may have a C-pillar only on one side.

Assign alphabetic designators A, B, and C only once for each particular longitudinal plane of the vehicle which contains a pillar. For instance, do not use multiple C-pillars to designate "opera windows." If there are more than four longitudinal pillar planes, all pillars behind the third set (C-pillars) are considered to be D-pillars, and damage to the worst damaged should be coded.

Check for consistency in pillar assignment with columns 56 and 57 on page VD-1.

For a pictorial description of pillars as they will be defined in the UMIVOR file, see Appendix: PILLAR STRUCTURE.

LEFT DOORS**HOW DID DOORS OPEN DURING COLLISION** (columns 43-44)
DOORS JAMMED CLOSED (columns 45-46)

If a door opened during the collision sequence, then the respective entry in column 43 or 44 should describe the cause for the opening ("1" through "9"). In such a case, the respective "jammed" entry should be "no" ("0" in column 45 or 46), even if the door jammed in the partially opened position.

It is possible, but rare, that a door can be separated from its hinges and still be jammed shut. In these cases, circle "hinge area separation", coding (0) door did not open, but code appropriate door jammed closed value in column 45 or 46.

Two-door vehicles do not have a side rear door. (Check for coding consistency with columns 56 and 57 on page VD-1.)

Canvas and/or snap-on door-opening covers are not considered doors for purposes of these questions, and the "not applicable" code (8) should be entered where appropriate.

An upward-opening door should be coded the same as a more conventionally swinging one.

A vehicle on which a sliding door has been left partially or fully opened should be coded as "unknown if opened" ("9" in columns 43 and [if applicable] 44) and "not jammed" ("0" in columns 45 and [if applicable] 46).

REAR DOOR (Page ED-4)**REAR DOOR TYPE** (column 47)

Code "no door" (0) for all vehicles with no rear opening directly accessing the passenger compartment. This includes most pickup trucks. Also code "no door" (0) for any vehicle which has a rear opening covered by a door which is not hinged or which does not fold away (for instance, is bolted or snapped on).

Code "hatchback" (1) both for hatchbacks, and for station wagons, multi-purpose passenger vehicles, and others with a single rear gate or window which is hinged at the top only. For example: AMC Gremlin.

Code "one-way tailgate" (2) for any vehicle with a rear gate or window which is hinged only at the bottom.

Code "two-way tailgate" (3) for any vehicle with a particular rear gate or window which is hinged both at the bottom and at one or both sides.

Code "clamshell/disappearing tailgate" (4) only for those vehicles which have a roll-away- or fold-away-type track in place of conventional hinges for all rear gates or windows.

Code "single door" (5) or "double door" (6), as appropriate, for those vehicles which have only vertical hinges; namely, where the door(s) can open only in a conventional, horizontally swinging manner.

Code "unknown" (9) both for "unknown if rear door" and for "rear door, type unknown."

HOW DID DOOR OPEN DURING COLLISION? (column 43)
DOOR JAMMED CLOSED (column 49)

If a door opened during the collision sequence, then the respective "jammed" entry should be "no" (0), even if the door jammed in the partially opened position.

If doors jammed closed, code yes regardless of hinge or latch separation. Circle appropriate separation on the form.

Canvas and snap-on door-opening covers cannot "open" or "jam" for the purposes of these questions, and the "not applicable" code (8) should be entered.

OTHER REAR DAMAGE

WAS PARTITION TO LUGGAGE AREA DAMAGED DURING COLLISION?
(column 50)

For purposes of this question only, this "partition" must be of substantial physical character, not merely a canvas or cardboard separator between the passenger compartment and the rear luggage or cargo area. Hatchbacks and multi-purpose passenger vehicles (for instance, vans and utility vehicles) generally do not have such a qualifying partition, and should be coded "not applicable" (8) here.

Code "unknown" (9) both for "unknown if applicable," and "applicable, unknown if damaged."

SPARE TIRE (column 51)

Code "unknown" (9) for "unknown if spare tire equipped," "unknown if attached prior to collision," and "attached prior to collision, unknown if separated during collision." The question should be answered irrespective of the physical location of the spare tire prior to impact. The tire might have been in the trunk, in the rear of the passenger compartment (in a van, for instance), or underneath the body structure (on a pickup truck, for instance).

Note that if one of the tires in use prior to the collision had been damaged, those responsible for towing the vehicle away may have put on the spare and left the damaged tire loose in the vehicle.

TRAILER HITCH TYPE (column 52)

Code "fifth wheel" (6) for pickup trucks equipped to tow trailers with a rear-bed-mounted hitch-point forward of the rear axle.

TRAILER TYPE (column 53)

If the vehicle being towed is of a general type which is normally capable of independent, self-propelled, self-contained operation, code as a "towed car" (5).

Classify as "other" (7) any type of trailer which is not directly described by one of the available categories.

RIGHT SIDE BODY MOUNT(Page ED-5)**DID BODY MOUNT SEPARATE? (column 54)**

This should be coded "yes" (1) only for a complete separation. Note that vehicles with a unitized body structure do not have body mounts. Check for consistency with the body structure entered in column 59 on page VD-1.

RIGHT PILLARS**PILLARS SEPARATED COMPLETELY (columns 55-62)**

*** (Circle any response where damage has occurred but not complete separation)***

Only a complete separation should be coded "yes" (1). Partial separation, cracking, or other damage short of a complete separation does not qualify. Circle any response to an area which suffers damage even though that pillar may have not separated completely. While this information will not be added to the data set, it could provide useful information to analysts searching the hard copy.

The lower portion of the pillar starts at the top of the belt line and extends downward to and including its attachment to the lower side rail. The upper portion starts immediately above the belt line and extends upward to and including its attachment to the roof side rail. If a complete separation occurs right at the belt line, both upper and lower portions should be coded as separated.

A vehicle coded as a "hardtop" ("11" or "13" in columns 56 and 57 on page VD-1) should have no upper B-pillars.

A vehicle coded as a "convertible" ("16" in columns 56 and 57 on page VD-1) usually has no upper B- or C-pillars. (This also applies to those multi-purpose passenger vehicles [MPV's] which have a removable roof or no roof at all.) The structure associated solely with the convertible top itself does not constitute an upper B- or C-pillar assembly.

A passenger vehicle has a lower C-pillar only if and where there is a side rear door with a latch (unless it has a tailgate or a hatchback, as described below). For example, a van with a side rear door on the right side has upper and lower A-, B-, C-, and D-pillars on the right side, even though it may have no left upper or lower C-pillar (because it has no left side rear door).

Most conventional passenger cars do not have D-pillars. Exceptions include four-door models with a window behind the side rear door (for instance, some hatchbacks, sedans with "opera windows," and station wagons). In those cases, the vehicle has an upper D-pillar, but no lower D-pillar unless there is an associated door and latch (following the same criteria as discussed for lower C-pillars in the previous paragraph), or unless there is a tailgate or hatchback (see below).

Any vehicle with a tailgate enclosing the rear of the passenger compartment has upper and lower rear pillars (C-pillars, or D-pillars if there are already C-pillars forward of the rear pillars). (Note that this excludes pickup trucks.) A "hatchback" also has at least rear upper pillars, plus rear lower pillars if the passenger compartment at the hatchback opening extends below the belt line.

Except as specified above, assign alphabetical designations to the pillars sequentially. For instance, if the vehicle has no C-pillars, then it can have no D-pillars. However (as noted above), a van may have a C-pillar only on one side.

Assign alphabetic designators A, B, and C only once for each particular longitudinal plane of the vehicle which contains a pillar. For instance, do not use multiple C-pillars to designate "opera windows." If there are more than four longitudinal pillar planes, all pillars behind the third set (C-pillars) are considered to be D-pillars, and damage should be coded.

Check for consistency in pillar assignment with columns 56 and 57 on page VD-1.

For a pictorial description of pillars as they will be defined in the UMIVOR file, see Appendix: PILLAR STRUCTURE.

RIGHT DOORS

HOW DID DOORS OPEN DURING COLLISION? (columns 63-66)

DOORS JAMMED CLOSED (columns 67-68)

VAN RIGHT-REAR DOOR TYPE (column 69)

If a door opened during the collision sequence, then the respective entry in columns 63 through 66 should describe the cause for the opening ("01" through "99"). In such a case, the respective "jammed" entry should be "no" ("0" in column 67 or 68), even if the door jammed in the partially opened position.

If doors jammed closed but hinge separation took place, code "jammed" column 67 or 68 and circle hinge separation above.

Two-door vehicles do not have a side rear door. (Check for coding consistency with columns 56 and 57 on page VD-1.)

Canvas and/or snap-on door-opening covers are not considered doors for purposes of these questions, and the "not applicable" code (98) should be entered where appropriate.

An upward-opening door should be coded the same as a more conventionally swinging one.

A vehicle on which a sliding door has been left partially or fully opened should be coded as "unknown if opened" ("99" in columns 63 and 64 or 65 and 66, as appropriate), including if the Case Vehicle is a van. In these instances, code the "jammed" questions which follow (columns 67 and 68) as "no" (0) as appropriate.

In column 69, code "unknown" (9) for "unknown if van," "van, unknown if right side rear door," and "van with right side rear door, unknown type."

WINDSHIELD DAMAGE (Page ED-6)

WINDSHIELD CRACKED (column 70)

This section should be completed even if the windshield was in a "folded-down" position (for instance, on a multi-purpose passenger vehicle).

WINDSHIELD BROKEN (column 71)

A break can be distinguished from a mere crack by a tear or penetration of the plastic interlayer (the "shatter-proof" protection layer). Code "not applicable" (8) only if there was no windshield, or no crack.

CRACKED OR BROKEN BY OCCUPANT CONTACT (column 72)

This includes any Case Vehicle occupant, not just those in the front seat.

EXTENT OF BOND SEPARATION (column 73)

This refers to the bond around the perimeter of the windshield. If there was more than one windshield component (for instance, two halves), include the total bond perimeter of all windshields, not just the bond perimeter of that segment which may have been damaged.

WINDSHIELD MARK (not coded)

Please record even though this information is not entered into the file. Descriptions and drawings of the Windshield Mark will assist later data analysts in cases where the mark is known but no code had previously been assigned to it.

WINDSHIELD CODE (columns 74-75)

This refers to a two-character code (generally, two letters) assigned by the manufacturer. See the M.V.M.A. Accident Investigator's Manual for the appropriate model year.

If reference to the specific monogram can be found in that Manual but no two-character code has been assigned to it, enter "described but not coded" (97). This will alert subsequent analysts to examine the hard-copy of this UMIVOR Report for further information.

Be sure to distinguish between the number "zero" (enter as "0") and the letter "O" (enter as "Ø").

ROOF**DID T-ROOF/SUN ROOF OPEN DURING COLLISION?** (column 76)

Response here should be consistent with the "type of roof" response designated in column 71 in the VD-2 module. Please double check your coding practice and respond accordingly. The question here asks if this opened roof was found open because of or due to, some aspect of the collision sequence. If it was a T-roof (or sun roof) and was not open or did not open because of the collision, then code "no" (0). (Convertible roofs do not apply here.)

WINDSHIELD DAMAGE PICTORIAL (bottom of page)

If any damage occurred to the windshield, carefully complete this drawing as accurately as possible, showing the dimensions of the primary features (center of occupant contact, point of penetration, etc.) and their distances from the windshield edges.

Module SC: STEERING WHEEL AND COLUMN

If the Case Vehicle is equipped with more than one steering wheel and associated hardware (for instance, on a dual-control driver-training car), complete this page only for the originally installed equipment, disregarding the supplementary control.

STEERING WHEEL (Indicate occupant contact by circling responses)**STEERING WHEEL RIM DAMAGE** (column 13)

If the steering wheel rim was cracked but otherwise not severely bent, code "deformed slightly" (1).

Code "unknown" (9) for "unknown if damaged," "damaged, amount unknown," and "unknown if steering wheel."

If the vehicle is equipped with a steering device other than a steering wheel (such as a "joy stick" or steering stalk), enter "not applicable" (8).

NUMBER OF STEERING WHEEL SPOKES (column 14)

Code actual number for up to seven spokes. If more than seven, code "7." Code "not applicable" (8) for "no steering wheel," and for "non-spoked steering wheel." Do not enter "0."

STEERING WHEEL SPOKE DAMAGE (column 15)

If a spoke was cracked but otherwise not severely bent, code "deformed slightly" (1). If the previous question was coded "not applicable" (8), code that here as well.

Code "unknown" (9) both for "unknown if damaged" and "damaged, amount unknown."

STEERING COLUMN OPTIONS**TILT FEATURE** (column 16)**SWING-AWAY FEATURE** (column 17)**TELESCOPING FEATURE** (column 18)

Code as appropriate.

STEERING WHEEL POSITION AT TIME OF COLLISION (no column entry)

Please record even though this information is not entered into the file.

STEERING WHEEL ENERGY ABSORBING DEVICE**TYPE OF DEVICE** (column 19)

Until recently, very few vehicles were equipped with this type of device. If the Case Vehicle is equipped with a Steering Wheel EAD of an unknown or unrecognizable type, code "other" (7). Code "9" only for "unknown if equipped." If "deep dish steering wheel" (2) is coded, (993) below might apply.

DIFFERENCE (columns 20-22)

In determining the post-crash "B" dimension, measure at that point on the periphery which indicates the maximum change from the original dimension.

The measurement tolerance is 10 mm. For a post-crash measurement which differs from the original dimension by less than 10 mm, enter "000."

If the steering wheel energy absorbing device above is a deep dish type, (993) might be used if this device is determined to be extended. Deep dish types do not compress.

Code (997) if you were unable to measure the difference.

Code "unknown" (999) for "unknown if equipped," "equipped, distortion unknown," and "device extended."

STEERING COLUMN ENERGY ABSORBING DEVICE (page SC-2A)**TYPE OF DEVICE** (columns 23-24)

The steering column energy absorbing device ("EAD") can be distinguished from a telescoping unit ("TU"; see page ED-1) in that the EAD is in the passenger compartment, whereas the TU is usually in the engine compartment.

Enter the appropriate two-digit number from the diagram of devices on the right side of page SC-2A, page SC-2B or page SC-2C. Another source for this information is the M.V.M.A. Accident Investigation Manual.

Note that those devices used on GM products have a first code digit of "1" and "2". Those used on Chrysler products have a first code digit of "3". Those used on Ford products have a first code digit of "4". Toyota is denoted by first digit codes of "5" and AMC products generally use components manufactured by GM.

COMPRESSION (columns 25-27)

The M.V.M.A. Accident Investigation Manual for the appropriate model year should be checked for original dimensions for all Case Vehicles.

The measurement tolerance is 10 mm. For a post-crash measurement which differs from the original dimension by less than 10 mm, enter "000."

Note that only compression is to be entered as an actual measure. If the device is extended (beyond the 10 mm measurement tolerance), enter "993."

Enter "991" if the EAD was not measured, but a visual inspection or other impact-related information suggests that there was probably no compression. If there was apparent or suggested compression, but the exact amount could not be measured (for instance, the EAD was inaccessible due to other impact damage, etc.), enter "992."

If measurement of the EAD was not possible (for instance, the EAD was inaccessible due to impact damage), and compression may have occurred but this cannot be determined for sure, enter "997." If no measurement was made for some other reason, and no clear suggestion is possible about compression, enter "unknown" (999).

The Energy-Absorbing-Device compression for Ford Escort and Lynx is actually measured by determining the measurement of the shear-capsule separation. Therefore, for these vehicles (coded 45 in columns 23 and 24) enter the same numbers in columns 25-27 as in columns 28-30 below.

SHEAR CAPSULE SEPARATION (columns 28-30)

The shear capsule must permit entire dislodgement, not mere motion within a slotted path. If entire dislodgement is not possible (namely, both ends of the sliding track are closed), the device is not a shear capsule, and "not applicable" (998) should be entered here.

Enter "991" if the shear capsule was not measured, but a visual inspection or other impact-related information suggests that there was probably no compression. If there was apparent or suggested compression, but the exact amount could not be measured (for instance, the shear capsule was inaccessible due to other impact damage, etc.), enter "992."

If measurement of the shear capsule was not possible (for instance, the shear capsule was inaccessible due to impact damage), and compression may have occurred but this cannot be determined for sure, enter "997." If no measurement was made for some other reason, and no clear suggestion is possible about compression, enter "unknown" (999).

Also code "unknown" (999) for "unknown if equipped."

COLUMN VERTICAL ROTATION (column 31)

Code "unknown" (9) for "unknown if rotation," and for "rotation, direction unknown."

COLUMN LATERAL MOVEMENT (column 32)

Code "unknown" (9) for "unknown if movement," and for "movement, direction unknown."

Caution must be exercised when examining front-wheel-drive vehicles. Some of the recent "new breed" mini-cars have a steering column which is canted slightly to the left, necessitated by the tight spacing in the engine compartment.

Module IT: **INTRUSION****LIST OF INDIVIDUAL COMPONENTS** (Page IT-2)

All intruding objects to be coded here must originally have been part of (or contained within) the Case Vehicle. Disregard any other objects which intruded into the passenger compartment. The codes for these intruding objects are found on page IT-2.

Code "05" includes both the steering column and the steering wheel spokes and rim.

Code "(internal) other" (25) for "pedals and foot controls."

Code "(external) other" (46) for objects which were originally part of the Case Vehicle, but were internal to some other compartment (for instance, in the trunk). This is distinguished from "object external to passenger compartment but part of the Case Vehicle" (44), in that the latter may include objects which were not internal to some Case Vehicle compartment, although they must still have been a part of the Case Vehicle itself.

INTRUSION RESPONSES (Page IT-3)**WAS THERE OCCUPANT COMPARTMENT INTRUSION** (column 13)

This applies only to intrusion by components which were originally part of or contained within the Case Vehicle. Disregard any other objects which intruded into the passenger compartment, except to the extent to which they also caused Case-Vehicle-component intrusion (such as by the windshield or by a door panel). Intrusion by glass from any window area other than the front windshield should not be coded.

WAS INTRUSION CATASTROPHIC (column 14)

This includes a demolition which is so total and overwhelming as to preclude identification of the individual components involved or any association between those individual components and particular injuries suffered by the Case Vehicle occupants.

INDIVIDUAL INTRUSIONS (middle portion of page IT-3, columns 13-30)

Code front-seat-space intrusions first, from left to right. Then code intrusions into the second and subsequent seat areas in succession, also from left to right within each seat-row space.

For each "intrusion number" line in which any entries have been made, all columns ("B" through "J") must be completed.

"Occupant Space" (column heading "B," column numbers 15 and 16) is defined on page IT-1. If more than one occupant space is involved, a separate "Intrusion Number" entry should be made for each. Neither a physical "seat" nor an actual occupant need to have been present for an "Occupant Space" to have existed. For instance, a van without rear passenger seats would still have "Occupant Spaces" such as diagramed on page IT-1.

"Intruding Component or Object" (column heading "C," column numbers 17 and 18) should be chosen from the list on page IT-2. If more than one component or object is involved, choose the exactly appropriate "combination item" (codes 51 through 64). If none of these are appropriate, enter each component or object individually on a separate "Intrusion Number" line.

"Associated Event Number" (column heading "D," column number 19) should correspond to the event-number sequence used on page DA-2. An unknown event number should be entered as "9." If more than one event was or may have been responsible for a given intrusion area, attempt to identify each on a separate "Intrusion Number" line. If that is not possible, code that particular intrusion which is likely to have caused the greatest physical penetration into the passenger compartment.

For a given space/object/event-number combination, multiple entries should not be made to reflect measurements along different axes.

"Maximum Intrusion" (column heading "E," column numbers 20 and 21) should be entered in centimeters. If this measurement is unknown, enter "99." Enter "98" for intrusions of 98 cm or more. The measurement plane must be strictly horizontal or vertical (according to the axis identified in the next column), with respect to the Case Vehicle's original "at-rest" stance.

"Measurement Axis" (column heading "F," column number 22) should be "X," "Y," or "Z," as described on page IT-1.

The coding for column headings "G" through "J" is described on page IT-1. Note that each of these four column groups must be completed if the preceding columns for that same "intrusion number" (column "A") have been completed.

If there were no contacts for a given intrusion, enter "no contact" (00/00) in columns "G" and "H," and again in columns "I" and "J."

If a particular intrusion resulted in a contact between that intruding object and an occupant, enter that occupant's number in column "G" and the associated "injury number" for that occupant in column "H." This "injury number" should correspond to the injury-number designation listed on that occupant's page IC-2. If there was no injury from that contact, enter "no injury" (00) in column group "H."

If a second occupant contact (whether to the same or to a different occupant) was also caused by that particular intrusion, then complete column

groups "I" and "J" as appropriate. If there was no such second occupant contact, then enter "no contact" (00/00) in these two column groups.

If two occupant/injury combinations were suffered for a given component intrusion, code first (in column groups "G" and "H") the occupant/injury combination which caused the greater degree of personal injury. If more than two occupant/injury combinations were suffered for a given component intrusion, code only the two which caused the greatest injury.

If (but only if) more than seven intrusion-number-line entries are necessary, use page IT-4.

Unused intrusion-number lines should be left entirely blank, and no line should be left blank if a subsequent intrusion-number line is completed.

SIDE DOOR INTRUSIONS (bottom of page IT-3)

SIDE DOOR INTRUSION RESULTED FROM (columns 13-21)

If no side-door intrusion exists, leave the entire lower portion of this page IT-3 blank. If more than one side-door intrusion exists, rank in order of most severe (first), from the standpoint of intrusion distance (column heading "E"). Code only the three most severe side-door intrusions from the preceding list.

Note that this question relates to the "Intrusion Number" identified in the immediately preceding Format. The responses entered here may represent intrusions which all resulted from the same impact.

IF DAMAGE TO DOOR COMPONENT RESULTED IN INCREASED DOOR INTRUSION, CODE COMPONENT (columns 22-37)

Entries should be made only if a failure in one of the components listed permitted greater side-door intrusion. If none, leave entirely blank.

Note that entries may have been made in the immediately preceding columns (13 through 21), without any being appropriate or needed here (columns 22 through 37); namely, a side-door intrusion can occur without having been caused or exacerbated by damage to or failure of any other component. However, any entries here (22 through 37) should be cited earlier (in 13 through 21). If any entry is made in one of the four lines ("A" through "D"), then that entire line (all four column spaces) must be completed.

The door component cited in this response as having been damaged need not itself have been an intruding component, but merely one whose damage permitted a greater degree of side-door intrusion.

INDIVIDUAL INTRUSIONS (continuation page IT-4)

If (but only if) there are more than seven qualifying intrusion-number-line entries, continue that list from the previous page here. However, not more than a total of twenty-six intrusion-number lines may be completed altogether, and no line should be left blank if a subsequent intrusion-number line is completed.

Module ID: **INTERIOR DAMAGE**

For this entire page ID-1, indicate any occupant contact by circling the response entered, whether or not that item was damaged. This provides a cross-check for later analysts who may want further information relating object contact to occupant injury, and permits quality control of injury scaling of occupant contacts.

This module is used to code damage to interior components. Damage should be coded "yes" (1) whether it was caused by impact forces or by occupant contact.

If vehicle interior was consumed by fire, code (9) "unknown" for all areas unless (8) "not applicable" applies.

SIDES**FRONT DOOR** (columns 13-14)

Responses relate to any portion of the front-entrance-portal covering other than the hardware, armrest, or glass.

If the door consists of a plastic covering or other form of relatively flimsy material (for instance, on a soft-door "jeep"-type vehicle), code as "not applicable" (8).

FRONT HARDWARE (columns 15-16)

This includes any type of hardware attached as original equipment to the inside of the respective door. Examples of hardware which might be on the door include ashtrays, map holders, handles for door or window openings, side-mirror remote-control knobs, and courtesy lights. Code any "after-market" equipment or modification in the "other" entries (columns 43 or 44) instead of here.

If the prior question has been coded "not applicable," code that (8) here as well.

FRONT ARMREST (columns 17-18)

This includes only an outer-side-of-seat armrest (for instance, as mounted on the door or on the outer side of a "captain's chair"), but not a center armrest or one mounted on the inner side of a "captain's chair."

If absent, code "not applicable" (8). If the "front door" questions (columns 13 and 14) have been coded "not applicable," code that (8) here as well.

FRONT GLASS (columns 19-20)

Code irrespective of window-level position (rolled up or down). If only a plastic or semi-flexible material is used, code as "not applicable" (8). If the "front door" questions (columns 13 and 14) have been coded "not applicable," code that (8) here as well.

REAR DOOR AREA (columns 21-22)

Note that this refers to an area, not to a door itself. If the Case Vehicle has rear seats (or a space where rear seats might normally be located), then by definition it has a "rear door area."

The "not applicable" code (8) should be used only for those vehicles which lack this area altogether (for instance, most pickup trucks and some "two-seater sports cars").

REAR HARDWARE (columns 23-24)

This can include any kind of original equipment hardware: ashtrays, door or window handles, latches on "push-out" windows, seat belt retractors, etc. A vehicle can have a rear seat without having any rear hardware, although some kind of hardware (for instance, seat belt retractor) is usually found.

As with the questions on front-door hardware, code any "after-market" equipment or modification in the "other" entries (columns 43 or 44) instead of here.

If the "rear door area" questions (columns 21 and 22) have been coded "not applicable," code that (8) here as well.

REAR ARMREST (columns 25-26)

This includes only a side-of-seat armrest (for instance, as mounted on the side panel, or on the outer side of a "captain's chair"), but not a center armrest or one mounted on the inner side of a "captain's chair." If absent, code "not applicable" (8). An armrest mounted on the end of a bench seat in a van, even if space for an aisle remains between that seat and the side panel, should also be coded here.

If the "rear door area" questions (columns 21 and 22) have been coded "not applicable," code that (8) here as well.

REAR GLASS (columns 27-28)

This refers specifically to any window glass or similar material located on the Case Vehicle's left and right sides behind the front door openings. Although there can be rear side glass even if there is no rear seat area, the presence of the former is usually accompanied by the latter. Check for possible inconsistency between columns 25 through 26 and columns 21 through 22.

Code irrespective of window-level position (rolled up or down). If only a plastic or semi-flexible material is used, code as "not applicable" (8).

ROOF SIDE RAIL (columns 29-30)

A convertible with its top on or up has roof side rails. A vehicle with a "T-top roof" has roof side rails if the roof area extends at all forward from the rear-most pillar structure. Multi-purpose passenger vehicles and utility vehicles with canvas roofs have roof side rails if there is any side-located roof support structure whatsoever (for instance, a metal rod).

B-PILLAR (columns 31-32)

This includes both upper and lower pillar segments. Any vehicle which has either a front or a rear door of substantive structure probably also has a B-pillar on that side.

For a pictorial description of pillars as they are defined in the UMIVOR file, see Appendix: PILLAR STRUCTURE.

C-PILLAR (columns 33-34)

This includes both upper and lower pillar segments, but excludes those C-pillars which are not part of the passenger compartment.

Any vehicle which has a side rear door of substantive structure probably also has a C-pillar on that side. Vans have a right-side C-pillar if they have a right-side rear door, but no C-pillar on the left side unless there is also a left-side rear door. (This is rare.)

If there is no side rear door, there can be no rear lower C-pillar, although there usually is an upper C-pillar, especially if there is a rear seat area. Note, that convertibles with the top in the "up" position, would have upper "C" pillars exposed in the passenger compartment. However, a two-door vehicle with a rear tailgate, or with a rear hatchback which also exposes a portion of the rear passenger compartment below the beltline, does have upper and lower rear pillars (C-pillars, or D-pillars if there are already C-pillars forward of the rear pillars). Check for consistency with the lower-C-pillar entries on pages ED-3 (column 40) and ED-5 (column 60).

For a pictorial description of pillars as they are defined in the UMIVOR file, see Appendix: PILLAR STRUCTURE.

D-PILLAR (columns 35-36)

This includes both upper and lower pillar segments. Most conventional passenger cars do not have D-pillars. Exceptions include four-door models with a window behind the side rear door (some hatchbacks, sedans with "opera windows," and station wagons).

Any vehicle with a rear-facing door, hatchback, or tailgate which exposes the rear end of the passenger compartment has a rear pillar (a D-pillar if there is also a C-pillar forward of that rear-most pillar). (Check for consistency with page ED-4, columns 47 through 49.)

HEADLINING (columns 37-38)
ROOF STRUCTURE (columns 39-40)

Any vehicle with a roof (in place) has at least a roof structure, even if it has no headlining. A convertible with its roof down or off has neither a roof structure nor a headlining.

Some pickups, vans, and other multi-purpose passenger vehicles may have a roof structure but no headlining. Any material other than a mere layer of paint which covers or shields the interior side of the roof structure constitutes a headlining.

T-ROOF/SUN ROOF (columns 41-42)

Interior damage suffered to T-roof/sun roof components is indicated here. Vehicles not equipped are denoted as (8) "not applicable". Consistency with column 71 VD-2 and column 76 ED-6 must be maintained. Code (I) "yes" if there is either frame damage, latch damage or glass damage caused either by crash dynamics or occupant contact.

OTHER (columns 43-44)

This is specifically for additional significant (including after-market) items located on the left or the right sides of the Case Vehicle's interior passenger compartment. More than one item can be referenced, but only one code entry should be made, and the specific items should be written in (and circled if there was occupant contact).

If there are no items of significance, code "not applicable" (8).

FRONT

FOOT CONTROLS (column 45)

Include any normally foot-actuated control accessible to the driver, except for the parking brake pedal (see column 61 below). Exclude any dual (redundant) control, such as might be found in a driver-training car.

IGNITION KEYS (column 46)

Code damage only if the ignition key itself was damaged. However, indicate occupant contact (by circling) if the occupant contacted the key or any object connected to the key ring.

REAR VIEW MIRROR (column 47)

This is solely for the interior-mounted rear-view mirror, and specifically excludes any exterior-mounted one.

Only original equipment devices should be coded. An after-market interior mirror should be coded as an "other" (columns 43 or 44 if mounted on a side interior surface; column 67 if mounted on the instrument panel) or ignored (if mounted elsewhere).

SUNVISOR/FITTINGS (column 48)

Code as appropriate. Include only the original equipment, and exclude any after-market attachments.

WINDSHIELD TOP MOULDINGS (column 49)

This can include any interior area forward of the roof structure, not just the perimeter bonding material for the windshield itself. For instance, some multi-purpose passenger vehicles have a windshield mounted on a nearly vertical metal plate. The upper portion of that plate (below the point at which it attaches to whatever roof structure may be in place) also constitutes a portion of the moulding area.

LEFT A-PILLAR (column 50)
RIGHT A-PILLAR (column 51)

Code as appropriate. If the upper A-pillars are folded down (for instance, on a "jeep"-type vehicle), they should still be coded here for damage and contact.

CONSOLE (column 52)

This refers to anything on the floor or hump between the front seats (but not to the hump itself) from which the occupant could receive an injury. The rubber boot on a floor-mounted transmission selector lever is not included, but a "mini-console" (for instance, on a Mustang II) is included.

This also refers to the front engine covers and access shields in vans, but only if the engine or drive-train components would (if left uncovered) significantly protrude into the passenger compartment.

TRANSMISSION SELECTOR LEVER (column 53)

This question does not distinguish that lever by location. Respond the same whether that lever is located on the steering column, on the control panel, on the floor, or on a "mini-console."

HORN, SPOKE SHROUD (column 54)

This also includes any control feature or hardware (for instance, "speed control" buttons) on the spoke shroud.

INSTRUMENT PANEL

UPPER PANEL (column 55)

MID PANEL (column 56)

LOWER PANEL (column 57)

In a conventional passenger vehicle, these panels extend across the entire front of the vehicle (namely, from left extreme to right extreme). These questions should be answered irrespective of where along the left/right continuum the damage or contact may have occurred.

The "lower panel" also includes any (original equipment) knee restraints or lower parcel shelf.

The following diagrams illustrate panel locations. "X" indicates the upper panel, "Y" the middle panel, and "Z" the lower panel.

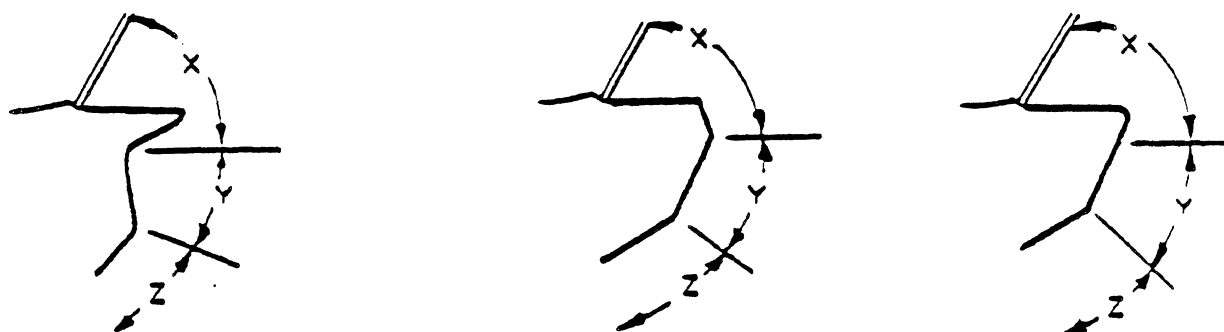
TYPICAL PANEL DIAGRAMS**ASHTRAY** (column 58)

This refers only to an original-equipment construction located in or under the instrument panel area. Code as an "other" in column 67 the presence, contact, or damage to any ashtray located on the center hump (for instance, in a mini-console), or any after-market ashtray located in or under the instrument panel area.

An original-equipment ashtray installed in a door panel should be coded as "hardware" on that panel (columns 15, 16, 23, or 24 respectively). An after-market ashtray installed on a door panel should be coded as an "other" (columns 43 or 44 respectively).

CONTROL KNOBS AND LEVERS (column 59)

This includes any original-equipment control knobs or levers, even if their damage would also be coded elsewhere as well. For instance, a damaged control knob on the radio would be coded both here and in column 66 below.

Exclude damage to any parking brake release knob or lever. It should be coded instead only in column 62 (below).

GLOVE COMPARTMENT AREA (column 60)

This refers to the entire right-side vertical area of the instrument panel (whether part of the upper, mid, or lower panel), not just to the glove compartment itself. A vehicle without a specific glove compartment usually still has a glove compartment area.

Right-side damage to the upper, mid, or lower panel should be coded both as panel damage (columns 55, 56, or 57) and here.

Damage to the glove compartment area solely from deployment of the passenger-side air bag should not be coded.

INSTRUMENTS (column 61)

This refers only to original-equipment instruments, but can include any gauges or visual (for instance, digital) displays, including a clock.

PARKING BRAKE RELEASE (column 62)

This might include the hand-applied parking-brake lever located between the two front seats, or a release-control knob or a handle mounted on or underneath the lower panel, for instance.

PARKING BRAKE PEDAL (column 63)

This applies only to a pedal mechanism. A hand-applied parking-brake lever located between the front seats should be coded only in the immediately previous column.

A/C OR UPPER VENT OUTLETS (column 64)**HEATER OR A/C DUCTS** (column 65)

Air-conditioning outlets are usually on the front or top of the instrument panel, as are the defroster- and upper-vent outlets.

The heater ducts are usually underneath the instrument panel.

RADIO (column 66)

This refers either to an original-equipment radio, or to an after-market one installed within the escutcheon panel. After-market radios installed elsewhere should be coded as an "other" (column 67). Damage to the control knobs of a radio coded in column 66 should be indicated both here and above in column 59.

OTHER (column 67)

This can include any after-market equipment mounted on the instrument panel or on the floor. More than one item can be referenced, but only one code entry should be made, and the specific items should be written in (and circled if there was occupant contact).

If there are no items of significance, code "not applicable" (8).

REAR**BACKLIGHT** (column 68)

Most vehicles are equipped with a backlight. This is the rear window in passenger cars, pick-up trucks and vans. It can be a double window in some vans and be non-existent in others (such as some delivery vans).

BACKLIGHT HEADER (column 69)

The backlight header is the moulding or frame above the rear window (or backlight) into which the glass has been positioned. If the vehicle has a backlight, it most likely will have a backlight header. If code (8) not applicable is used for column 68, use (8) not applicable here as well.

Module ST: SEATS**FRONT SEAT****TYPE OF FRONT SEAT (columns 13-16)**

Codes "01" through "04" refer to the nature of the seat-back construction, not to that of the seat bench. The presence or absence of a center armrest is immaterial.

For purposes of definition in the UMIVOR file, a "bucket" seat (05) must always be either track mounted or fixed, and a "captain's chair" (06) must always be pedestal mounted. (This admittedly somewhat arbitrary distinction is necessitated by the absence of any other criterion for clearly distinguishing between "bucket" and "captain's chair" seats.)

Check for consistency with the next question on type of mount (columns 17 and 18). Either type may or may not swivel, may or may not have an integral head restraint, and may or may not have integral armrests, but these characteristics are immaterial in distinguishing between a "bucket" and a "captain's chair."

Code "unknown" (99) both for "unknown type of seat" and "unknown if seat."

TYPE OF SEAT MOUNT (columns 17-18)

Code "standard" mount (1) for any type of longitudinal track or permanently bolted down frame, other than for one used as the base for a pedestal mount.

A "pedestal" mount (2) must have an actual pedestal extent, not merely a swivel-type base (which could be two flat-plate faces, for instance).

The "not applicable" code (8) should be used only where there is no seat. Code "unknown" (9) both for "unknown type of mount," and for "unknown if seat."

SWIVEL MECHANISM EQUIPPED (columns 19-20)

"Swivel" can also include merely "swing-out" designs. The swivel action need not enable the seat to turn inward, nor entirely around to the rear.

Code "not applicable" (8) only where there is no seat. Code "unknown" (9) both for "unknown if swivel mechanism," and for "unknown if seat."

ORIGINAL EQUIPMENT SEATS (columns 21-22)

This refers to the basic structural mechanism, not to the covering materials. A merely re-upholstered seat would still be original equipment. However, an original seat which had been relocated within the vehicle (for

instance, to or in the rear of a van) should not be considered "original equipment." Any other alteration which requires modification of the seat mounting mechanism or hardware would also make that seat not "original equipment."

Code "not applicable" (8) only if there is no seat. Code "unknown" (9) both for "unknown if seats are original," and for "unknown if seats."

CONTACT OF SEAT BY REAR OCCUPANT (columns 23-24)

This must be by a Case Vehicle rear occupant who was located in the rear prior to the beginning of the collision sequence.

Code "not applicable" (8) both for "no rear occupant," and for "no seat." Code "unknown" (9) for "unknown if contacted by a rear occupant," for "contacted but unknown if any rear occupant," and for "unknown if seat."

FRONT SEAT DAMAGE (columns 25-26)

Code "none" (0) only if there is no front-seat damage. Code "not applicable" (8) only if there is no seat. Code "unknown" (9) both for "unknown if damage," and for "unknown if seat."

CENTER ARMREST DAMAGED (column 27)

A bucket seat or a "captain's chair" may have an integral armrest on its interior face. This also constitutes a "center armrest." A console does not constitute an armrest, unless it also has a distinct armrest area.

Code "no" (0) only when there was a center armrest which was not damaged. This is a damage question and not an "equipped" "yes/no" question.

FRONT SEAT-BACK

OBVIOUS SEAT-BACK ROTATION (columns 28-29)

Code "not applicable" (8) when no seat is present, or when the seat has no back. Code "unknown" (9) for "unknown if damage," for "damage, direction unknown," and for "unknown if seat."

SEAT-BACK TYPE (columns 30-31)

Generally, only two-door vehicles have forward-folding front seats (1).

"Reclining" (3) refers to a manual rearward folding of the seat back alone. A "tilting" adjustment, on the other hand, includes both the seat cushion and the seat back and is accomplished by an electrical motor rather than by manual adjustment. A "tilting" adjustment is instead to be coded in columns 48 and 49.

If the front seat both folds forward and reclines rearward, code only the forward-folding function (1).

Code "not applicable" (8) either when there is no seat, or when the seat has no back. Code "unknown" (9) both for "unknown if folding," and for "unknown if seat." If it is known that the seat folds in one direction but it is not known if it folds in the other, code the known direction.

SEAT-BACK LOCK TYPE (columns 32-33)

This applies to the forward-folding (but not tilting or rearward reclining) motion. Code "none" (0) only for a seat back which folds forward but has no lock.

Code "not applicable" (8) for a seat back which does not fold, for a seat which has no back, and for "no seat." Code "unknown" (9) for "unknown if folding back," for "folding back, unknown if lock," and for "unknown if seat."

LOCKS HELD (columns 34-35)

This refers to the lock's action during the collision sequence. An inertia or manual lock may not have held during the collision sequence, but be in proper working order afterwards. In such an instance, enter the "no" code (0) here.

Damage can also occur solely during occupant extrication, or during an occupant's panicky exiting after the collision. In such an instance, code the lock as having held (1).

RECLINER MECHANISM HELD (columns 36-37)

If it is known that the seat reclined or was in a reclined position (whether manual or electrically controlled) code (1) "yes" if this mechanism held (whether or not the seat was occupied). Code (8) "not applicable" if the seat did not recline - or there was no seat and code (9) if it is unknown if the seat reclined, unknown if the mechanism held, or unknown if there was a seat.

HEAD RESTRAINT

HEAD RESTRAINT TYPE (columns 38-39)

This question refers to the Case Vehicle's originally manufactured condition, not as it may have been subsequently modified, for instance by removal of the head restraint. Code "none" (0) only if the vehicle as originally manufactured had no head restraint for that particular seat.

Code "not applicable" (8) only if there is no seat. Code "unknown" (9) both for "unknown if originally equipped with head restraint," and for "unknown if seat."

REMOVED PRE-CRASH (columns 40-41)

Code "not applicable" (8) if there is no seat, if the seat never had any original-equipment head restraint, or if the head restraint is integral to the seat back, or not integral but cannot be removed.

Code "unknown" (9) for "unknown if removed," for "unknown if seat originally equipped with restraint," and for "unknown if seat."

ADJUSTMENT AT CRASH (columns 42-43)

Code "up" (1) if the restraint had been moved any distance whatsoever above the "entirely down" position prior to the collision sequence.

Code "not applicable" (8) for "no restraint," for "integral restraint," and for "no seat." Code "unknown" (9) for "unknown adjustment," for "unknown if integral," for "unknown if equipped," and for "unknown if seat."

HEAD RESTRAINT DAMAGE (columns 44-45)

Code damage for an integral restraint the same as for an adjustable one. "Separated" (2) should be coded only if there was a complete separation between the structural components of the head restraint and those of the seat back.

Code "not applicable" (8) both for "no restraint" and for "no seat." Code "unknown" (9) both for "unknown if restraint," and for "unknown if seat."

FRONT SEAT ADJUSTMENT (page ST-2)**SEAT ADJUSTMENT TYPE** (columns 46-47)

Code as appropriate.

ADJUSTMENT PROVIDED (columns 48-49)

This question is concerned with only three adjustment modes:

Type A) linear parallel to the vehicle's longitudinal axis (forward/rearward motion);

Type B) linear parallel to the vehicle's horizontal axis (upward/downward motion); and

Type C) rotational about a horizontal axis through the seat cushion and parallel to the vehicle's lateral axis (tilting motion).

This is not concerned with other forms of motion or adjustment. Some are coded elsewhere. (For instance, rotational motion about the vertical axis through

the seat should be coded as "swivel" [columns 19 and 20 earlier].) Others should be ignored.

Code "2-way" (1) for a seat which has either a Type A (forward/rearward) or a Type B (upward/downward) adjustment, but not both, irrespective of the presence or absence of a Type C adjustment (tilt).

Code "4-way" (2) for a seat which has both a Type A (forward/rearward) adjustment and a Type B (upward/downward) adjustment, but not a Type C kind (tilt).

Code "6-way" (3) for a seat which has all three types of adjustment identified above (forward/rearward, upward/ downward, and tilt).

The "other" code (7) should be avoided except for truly extraordinary installations. Code "not applicable" (8) if there is no adjustment or no seat. Code "unknown" (9) for "unknown if or what type of adjustment," and for "unknown if seat."

SEAT ADJUSTER DAMAGE (columns 50-51)

Code the most severe type of damage suffered (priority: separated [3], deformed [2], "chucking" (partial movement while in a normally securely latched position) [1], but only by those adjustment hardwares functional in one of the three modes described above.

Code "not applicable" (8) if there is no adjustment or no seat. Code "unknown" (9) for "unknown if adjustment available," for "unknown if damage," and for "unknown if seat."

SEAT ADJUSTER SEPARATION (columns 52-53)

If separation was coded in the previous question, describe here the precise location, if possible.

Code "separated at floor" (1) if the primary separation occurred exactly between the floor and the lower edge of the mounting hardwares. This is a specific point.

Code "separation of adjuster" (2) if the primary separation occurred at any point between the lower edge of the floor mounting hardwares and the highest of the adjuster hardwares. This is a range of possible separation points.

Code "separated at seat" (3) if the primary separation occurred between the highest of the adjuster hardwares and the seat mounting structure. This is again a specific point.

Code "not applicable" (8) both if there is no adjuster and if there is no seat. Code "unknown" (9) both for "unknown if any separation," and for "separation, location unknown."

PRE-CRASH POSITION (columns 54-55)

Enter the pre-crash position for the respective seat. Code "not applicable" (8) only if there is no seat. Code "unknown" (9) both for "position unknown," and for "unknown if seat."

If the seat had no adjustment available, enter the code value ("forward" [1], "middle" [2], or "rearward" [3]) which best describes its fixed position.

SECOND SEAT

All questions on the second seats (columns 56 through 74, the remainder of this page ST-2) pertain only to original-equipment seats, and then only if they are physically attached and secured to the Case Vehicle interior structure. The descriptions and dispositions of any second seats which do not meet this criteria do not qualify to be recorded on this page.

TYPE OF SECOND SEAT (columns 56-57)

Enter the appropriate response. Code "unknown" (9) both for "unknown if seat," and for "seat, type unknown." Code "none" (0) if there is no qualifying seat in that position.

SECOND SEAT DAMAGE (columns 58-59)

Code "not applicable" (8) only if there is no qualifying second seat. Code "unknown" (9) both for "unknown if damage," and for "unknown if qualifying second seat."

CENTER ARMREST DAMAGED (column 60)

A bucket seat or a "captain's chair" may have an integral armrest on its interior face. This constitutes a center armrest, and should be coded here. Newer vehicles which may be equipped with dual second-seat center armrests should be coded (I) "yes" if EITHER of these center armrests are damaged and the investigator should indicate in the margin which armrest suffered the damage.

Step vans usually have an armrest on the right end of the second-seat opposite the steps. Code this as center armrest.

Code "not applicable" (8) both for "no center armrest," and for "no qualifying seat." Code "unknown" (9) both for "unknown if equipped," and for "unknown if qualifying second seat."

SECOND SEAT-BACK LOCKS (columns 61-68)

As used in this section, "second seat-back lock" refers to an actual latching mechanism, not merely to a friction-type "detente" position or device. This latching mechanism must require some form of overt manual activation (beyond merely applying forward pressure to the rear of the seat back) to cause its release.

The necessity of the complicated set of questions which follows results from the possibility that a second seat (or seats) can be more than a mere bench-type installation. There are vehicles designed with a second (or rear) seat which is split. This allows for lengthy loads to be transported on ONE side of the vehicle and still have an occupant sitting in the second-seating row, on the other side. Therefore, we must deal with the possibility that each of these independent second-row seats can (or will) be equipped with two sets of seat-back locks (one on either side of this independent seat.) Hence,

There are entries here for up to four seat/lock combinations. (Two for each side of the vehicle). Columns 61 and 63 pertain to locks on the left side of the second seat (the second row of a station wagon or the rear seat of smaller wagons or hatch-back type vehicles.)

Columns 65 and 67 pertain to locks on the right side of a qualifying left seat (if any). Columns 62 and 64 pertain only to locks on the left side of a qualifying right seat (if any). A single lock at the center of a qualifying bench seat should be coded only in columns 62 and 64.

If the second seat (group) was not a qualifying folding type, code all of these entries (columns 61 through 68) as "not applicable" (8). If the second row had one or more qualifying folding seats, code the absence of a lock in those locations as "no" (a "0" in columns 61, 62, 65, or 66, as appropriate), and the "held" response for the respective "no" entry as "not applicable" (8).

If the lock was present on a qualifying seat, code the "equipped" question as "yes" (1), and then complete the respective "held" question as follows:

- 1) If the seat back was upright and the lock held, code "yes" (1).
- 2) If the seat back was upright and the lock did not hold, code "no" (0).
- 3) If the seat back was not latched in the upright position (whether or not it was latched in some other position), code "seat folded down" (3).

Below are given several examples of how the entries would actually appear in columns 61 through 68 on UMIVOR page ST-2 for qualifying seats.

EXAMPLE ONE: Second Row Seat Back Does Not Fold.

	Left	Right
Left or Center, Equipped	8	8
Left or Center, Held	8	8
Right, Equipped	8	8
Right, Held	8	8

**EXAMPLE TWO: Folding Second Row Bench-type Seat Back,
Has Latch Only on Right Side.
Back Upright and Latched at Impact:
Latch Held.**

	Left	Right
Left or Center, Equipped	0	0
Left or Center, Held	8	8
Right, Equipped	0	1
Right, Held	8	1

**EXAMPLE THREE: Folding Second Row Bench-type Seat Back,
Has Latches on Both Sides.
Seat Back Upright and Latched at Impact:
Left Latch Held, Right Latch Released.**

	Left	Right
Left or Center, Equipped	1	0
Left or Center, Held	1	8
Right, Equipped	0	1
Right, Held	8	0

**EXAMPLE FOUR: Folding Second Row Split Seat Backs.
Left Seat Back Has Only a Left-Side Latch,
Left Seat Back "Down" at Impact.
Right Seat Back Has Latches on Both Sides,
Right Seat Back Upright and Latched at Impact:
Left Latch Released, Right Latch Held.**

	Left	Right
Left or Center, Equipped	1	1
Left or Center, Held	3	0
Right, Equipped	0	1
Right, Held	8	1

THIRD SEAT**EQUIPPED** (columns 69-70)

This question asks if a qualifying seat was securely attached in the respective position at the time of impact. Code "yes" (1), "no" (0), or "unknown" (9). Use no other codes for these two columns.

BACKREST DAMAGED (columns 71-72)

Code "yes" (1) or "no" (0) only if that response pertains to a qualifying seat in that location.

Code "not applicable" (8) if there is no qualifying seat, or if a qualifying seat there has no backrest. Code "unknown" (9) both for "unknown if qualifying seat," and for "unknown if backrest on a qualifying seat."

CUSHION DAMAGED (columns 73-74)

Code "yes" (1) or "no" (0) only if that response pertains to a qualifying seat in that location.

Code "not applicable" (8) if there is no qualifying seat, or if a qualifying seat there has no cushion. Code "unknown" (9) both for "unknown if qualifying seat," and for "unknown if cushion on a qualifying seat."

REAR HEAD RESTRAINTS**VEHICLE EQUIPPED WITH REAR HEAD RESTRAINTS** (column 75)

If vehicle does not have rear head restraints in any position (either not original equipment or removed) code (0) not equipped.

If equipped in any position of rear seats, code (1) equipped.

If any rear-seat head restraint is damaged code (2) equipped and damage.

Module AB: AIRBAG

Driver-side airbag equipped vehicle responses are located on left side of the page. Passenger airbag equipped vehicle responses are found on the right side of the page. Use codes which apply to each side. This module is filled out completely even if vehicle is not equipped with either side airbag.

AIRBAG RESPONSES

If the vehicle being investigated is not equipped with an airbag, fill out all questions (columns 13-18) with "no" (0), "not reinstalled" (4) and "not applicable" (8) responses.

Vehicles may be equipped with driver side airbags (left column) on the steering wheel only. Complete columns 13, 14, 15 with proper responses and fill in the right columns (16, 17, 18) with (0), (8), (8) respectively.

If vehicle is equipped with both driver and passenger side airbags, fill in all columns with proper responses.

AIRBAG NUMBER (not coded)

Located on the back of a deployed airbag.

Please record even though this information is not entered into the file. Description of the airbag will assist later data analysts.

AIRBAG DIAGRAMS

If any damage occurred to the airbag(s) please note and describe on the diagram(s) at the bottom of page AB-1.

Module OC: **OCCUPANT INFORMATION**

Separate OCCUPANT INFORMATION pages must be completed for each occupant in the Case Vehicle. Any person who was in or on that Case Vehicle should be included. Unoccupied vehicles should NOT have Module OC completed.

TEAM REPORT NUMBER (upper right corner, page OC-1)

Enter the first line of the Team Report Number as recorded in columns 18 through 27 of page AD-1. Since OCCUPANT INFORMATION pages for Case Vehicle occupants other than just the first are not included in the same binding, this entry will minimize the chance that those other pages might become lost or attached to the wrong UMIVOR Report.

OCCUPANT IDENTIFICATION

OCCUPANT NUMBER (columns 13-14)

Assign a separate number to each occupant, starting with 01 for the driver and proceeding sequentially. Once again, if the vehicle was unoccupied, DO NOT fill out OC-1.

ROLE OF OCCUPANT AT FIRST IMPACT (column 15)

No more than one "driver" should be indicated for the Case Vehicle. For a multiple-control vehicle (a driver-training vehicle, for instance), indicate "driver" only for the occupant in primary control of that vehicle at the time of initiation of the collision sequence.

A "passenger" can include any person located in or on the Case Vehicle at the time of initiation of the collision sequence.

OCCUPANT POSITION

ROW LOCATION (column 16)

Count rearward from the front. If there is more than one passenger compartment (for instance, a camper body on a pickup bed), code only the compartment containing the driving position. Record the others as "external to passenger compartment" (8).

If the rear seats face sideways instead of forward or rearward, code row location as "other" (7).

LATERAL LOCATION (column 17)

Include only the passenger compartment containing the driving position. For sideways-facing seats, code lateral location as "unknown" (9).

POSTURE (columns 18-19)

Code as appropriate. If the occupant is sitting normally on a seat which faces sideways, code "other" (97) and describe.

PHYSICAL DESCRIPTION**AGE IN YEARS** (columns 20-21)

Enter the occupant's age in years as of his or her most recent birthday. Do not increment this number upward (for instance, "25 and one half" to "26"). However, if only an approximate age is known, enter that approximate age. The following codes may be used:

- 00 Less than one year old.
- 01-97 One to ninety-seven years old (as appropriate).
- 98 Ninety-eight or more years old.
- 99 Unknown exact or approximate age.

AGE IN MONTHS (columns 22-23)

This question will assist analysis of infant involvement. The following codes may be used:

- 00 Less than one month old.
- 01-24 One to twenty-four months old (as appropriate). (Do not increment this number upward [for instance, "ten and one half" to "eleven" months]).
- 25 Twenty-five months or older, whether or not the precise age is known. Use this code for all adults and for all children above the age of twenty-five months.
- 98 Less than twenty-five months old, but precise age unknown.
- 99 Unknown if less than twenty-five months old.

EXAMPLES: If the occupant age is 3 months, code 00 in columns 20-21 and 03 in columns 22-23.

If the occupant age is 16 months, code 01 in columns 20-21 and 16 in columns 22-23.

If the occupant age is 3 years or greater, code actual age in columns 20-21 and 25 in columns 22-23.

MASS (columns 24-26)
HEIGHT (columns 27-29)

Enter as appropriate, using the metric standards indicated.

SEX (column 30)

Code as appropriate.

MEDICAL CONDITIONS

TREATMENT/MORTALITY (columns 31-32)

Code "99" both for "unknown if treated," and for "treated, extent unknown."

INJURY SEVERITY SCORE (ISS) (column 33-34)

The Injury Severity Score (ISS)¹² is a two-digit number equal to the sum of the squares of the highest AIS (Abbreviated Injury Scale¹³) values in the three most severely injured body regions. These regions are listed in the following Table 4¹⁴.

If the occupant has suffered multiple injuries within the same body region, only the AIS score for the most severe injury within that region may be used in the calculation of the ISS, even if there are less than three body regions in which injuries have been suffered.

¹²Described by Baker et al, "Injury Severity Score: A Method for Describing Patients with Multiple Injuries and Evaluating Emergency Care." For a complete listing of bibliographic materials, see the ANNOTATED BIBLIOGRAPHY.

¹³Described in The Abbreviated Injury Scale (1985 Revision). See the ANNOTATED BIBLIOGRAPHY. For a further discussion of the AIS scoring system, see the Appendix: OIC CODES AND VALID COMBINATIONS.

¹⁴Table Four reprinted from Petrucelli, Elaine (et al), Injury Coding Manual, Revised Edition, page 4. See: ANNOTATED BIBLIOGRAPHY.

TABLE 4
Injury Severity Score:
Definition of Body Regions

Body Region	Contents
Head or Neck	Brain, skull, cervical spine, ears (internal)
Face	Mouth, eyes, nose, facial bones, [does not include frontal bone]
Chest	All internal thoracic organs, diaphragm, rib cage, thoracic spine
Abdominal or pelvic contents	All internal abdominal organs, lumbar spine
Extremities or pelvic girdle	All injuries to extremities and bony pelvis, except spinal column, skull and rib cage
External	All integumentary injuries, such as lacerations, contusions, abrasions, and burns, independent of their location on the body surface

The following example demonstrates the ISS calculation. The injuries suffered include a ruptured spleen, a contusion of the left wrist, and lacerations of the forehead and right thigh.

<u>Injury</u>	<u>AIS</u>	<u>ISS Region</u>
Ruptured spleen	4	Abdominal or pelvic contents
Forehead laceration	1	External
Right thigh laceration	1	External
Left wrist contusion	1	External

$$ISS = (4)^2 + (1)^2 + (0)^2 = 17$$

NON-IMPACT MEDICAL CONDITIONS (column 35)

If the occupant drowned subsequent to ejection or as a result of the vehicle running off the road into a river or some other body of water, code as a "post-crash fatal (drowning)" (5).

Otherwise, a "post-crash" medical condition ("5" or "6") can exist only as the result of some incident which occurred solely after cessation of the collision sequence (namely, all vehicles and contacted objects had come to a complete halt).

For instance, if the occupant suffered injuries from a fire which stemmed from some collision-sequence-related event (such as a fuel tank rupture and subsequent leakage), this should not be coded "post crash" ("5" or "6"), even though the fire itself did not start until after cessation of the collision sequence.

POLICE INJURY SEVERITY CODE FOR THIS OCCUPANT (page OC-2 (column 36)

Police reports contain severity codes for injuries sustained by occupants in motor vehicle crashes. Code here in column 36, the injury severity for this occupant designated by the police. If no indication is listed by the police, code (9) "unknown". (Often if an occupant suffers no apparent injury, the police will not list anything opposite this occupant's name. You may be able to ascertain this information from the narrative portion of the police report.) If not, (9) should be coded.

RESTRAINT SYSTEM

ACTIVE RESTRAINT SYSTEM (column 37)

Code the hardwares actually available, not those with which the vehicle was originally equipped.

ACTIVE RESTRAINT SYSTEM USAGE (column 38)

Code actual use. Code "unknown" (9) both for "unknown if available," and for "unknown if used." If an active restraint system is used to contain a child seat, code usage code which applies. Frequently it has been observed that occupants are restrained BUT have secured themselves (or even tethered a child restraint) improperly. If this is apparent, use the code (7) "improper usage".

PASSIVE RESTRAINT SYSTEM (column 39)

Code here for original equipment. For instance, if an air bag had previously deployed but had not been re-installed, code its original presence (1).

If both an air bag and some other form of passive restraint were available to this occupant position, code information only for the former in this and the following questions (columns 39 and 40).

PASSIVE RESTRAINT SYSTEM USAGE (column 40)

If the system is disconnected totally code (0) "system defeated".

Should the passive restraint system be defeated by using the system in the manual mode, code (6).

Frequently it has been observed that occupants are restrained BUT have secured themselves improperly (i.e. belt is under the arm, around occupant's back, or left too loose). If this is apparent, use the code (7) "improper usage".

Code "unknown" (9) both for "unknown if available," and (in air-bag-equipped vehicles only) for "unknown if deployed."

CHILD SEAT TYPE (columns 41-42)

Use the age of six years as the cut-off criterion. If the occupant is less than six years old, code "00," "01," or "99," as appropriate. If the occupant is six or more years of age, code "98."

Code "unknown" (99) both for "qualifying child occupant, child-seat usage unknown," and for "unknown if qualifying child."

CHILD SEAT MAKE/MODEL

If this seat position was equipped with a child-restraint seat, harness, or other device, record here the type (make and model) for later analysis and review.

Please describe the child seat as best you can. Describe child seat in vehicle whether or not it was being used at the time.

EJECTION

DEGREE OF EJECTION (column 43)

"Partial ejection" (1) should be coded if any part of the occupant's body went outside the boundary of the vehicle. Occupants who jumped or were pushed from the vehicle while it was still in motion before cessation of the collision sequence should be coded as ejected. If, in the case of intrusion into the occupant compartment, the occupant comes in contact with the intruding component (i.e. a pole, sign, tree, etc.) the boundary of the vehicle has not changed but intrusion has occurred. Ejection has not taken place, intrusion has, and should be coded in the IT Module.

AREA OF EJECTION (columns 44-45)

Code "other area" (97) for instance for an ejection towards the front from a torn-away "dog house" (namely, a separation of the passenger compartment from the engine compartment behind the cowl).

For an ejection from a vehicle which suffered massive loss of integrity of the entire passenger compartment shell, attempt to code the most appropriate response. If none can be clearly determined, code "ejected, area unknown" (96).

EJECTION DESCRIPTION (bottom of right column of page OC-2)

Carefully describe the ejection path and the contact with the vehicle and with all external objects.

HEAD RESTRAINT**HEAD RESTRAINT AVAILABLE FOR THIS POSITION** (column 46)

Head restraint available for this position use codes available.

PICTORIAL DESCRIPTIONS (page OC-3)

Describe pictorially the nature of all soft-tissue and skeletal injuries. These descriptions are of utmost importance to analysts looking at occupant injuries and injury-causation factors. Cross-check for consistency between the pictorial descriptions here and the information recorded on page IC-2.

To demonstrate the format which should be most useful to analysts, a Sample Case is described on the next three pages, including a copy of the pages OC-3 and IC-2 which should accompany such an occupant's report.

SAMPLE CASE

Below is a list of possible injuries to an occupant of a vehicle involved in a traffic accident. This list is followed by the Diagram Page (OC-3) with the injuries documented accordingly. An Injury Classification Page (IC-2) for these same injuries can be found on page 105 in this Manual.

<u>Injury</u>	<u>Probable Contact Area</u>	<u>OIC</u>
1) Concussion, unconscious < 1 hour, no neurologic deficit	A-pillar	HWKB-2
2) Laceration, left ear	Window glass	HLLI-1
3) Contusion, left eyelid	A-pillar	FLLO-1
4) Closed fracture, maxilla	A-pillar	FIFS-2
5) Contusion, larynx	Steering wheel	NACR-2
6a) Laceration, right lung, superficial	Steering wheel	CRLP-3
6b) Fracture, right anterior third and fourth ribs, with hemothorax	Steering wheel	CRFS-3
7) Contusion and abrasion, upper abdomen	Steering wheel	MSCI-1 MSAI-1
8) Dislocation, left elbow	Left door interior	ELDJ-2
9) Abrasion, dorsum left hand	Window glass	WLAI-1
10) Comminuted fracture, pubic ramus	Steering wheel	PAFS-3
11) Strain, lumbar spine	Impact force	BITM-1
12) Tear, cruciate ligament, left knee	Lower instrument panel, unknown	KLLJ-3
13) Contusion, right thigh	Steering wheel	TRCI-1
14) Sprain, right ankle	foot pedals, floor	QRSJ-1

INDICATE LOCATION OF INJURIES, INCLUDING MAJOR BRUISES.

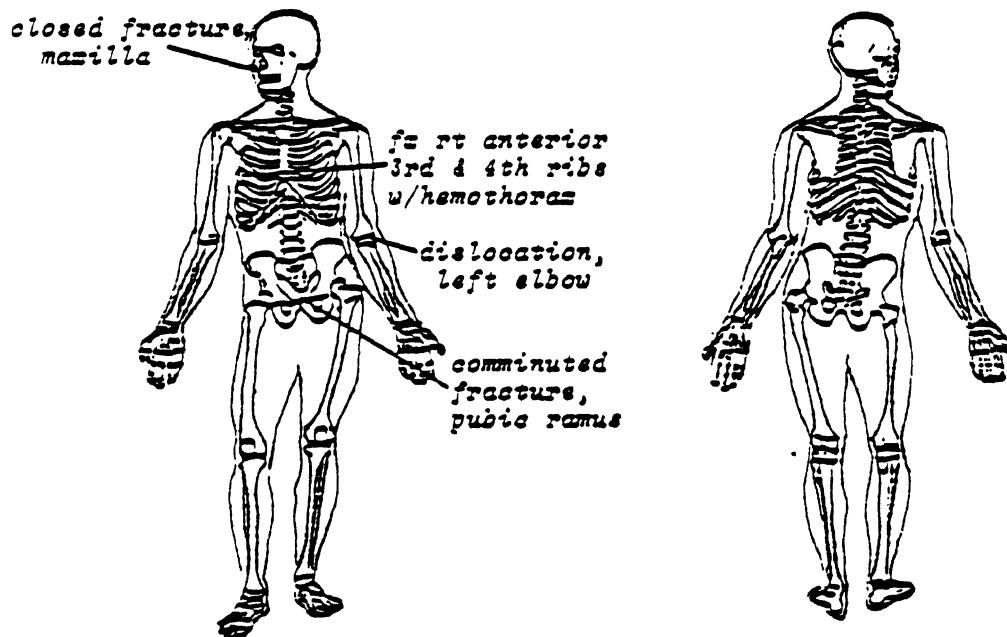
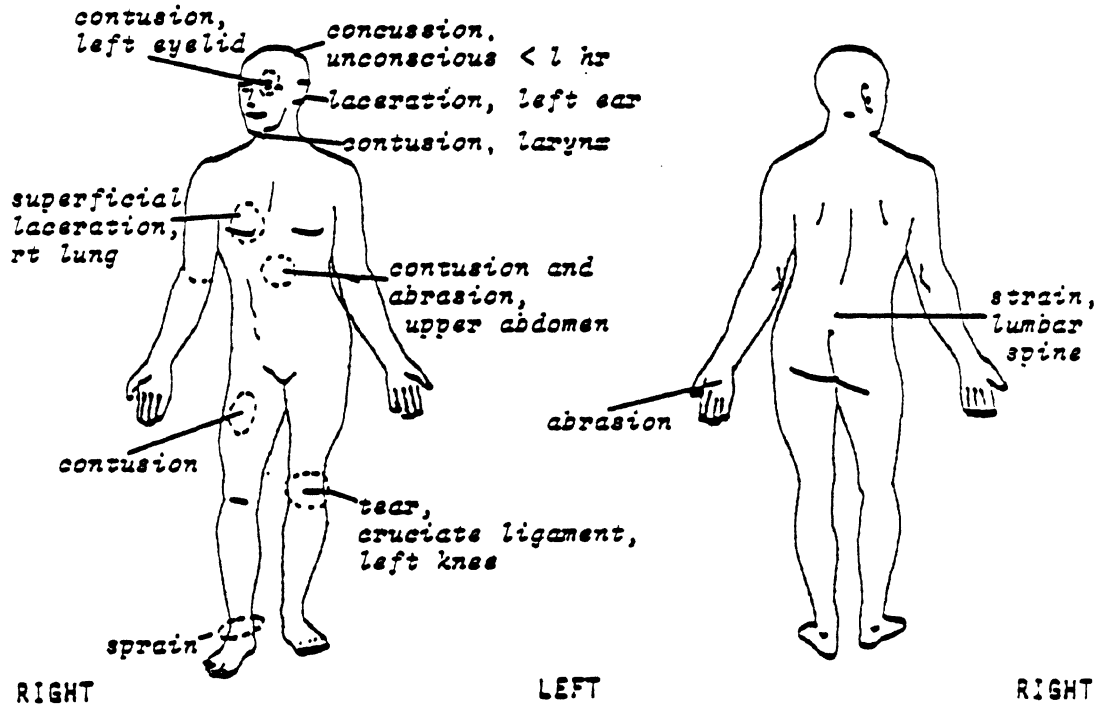

Module IC: **INJURY CLASSIFICATION**

A separate INJURY CLASSIFICATION Page IC-2 must be completed for each occupant in the Case Vehicle. Any person who was in or on that Case Vehicle should be included. To minimize later confusion, attach this Page IC-2 to the OCCUPANT INFORMATION pages for the respective occupant.

The Occupant Injury Classification (OIC)¹⁵ is a scheme to record each individual injury which the occupant has sustained. UMIVOR page IC-2 documents each OIC for a given Case Vehicle occupant, and relates that injury to possible areas of contact within the Case Vehicle or to other injury agents.

Injuries which are attributable to a collision-sequence-related fire should always be coded. If the fire causing that injury was not related to a collision sequence, then the injury should not be coded here.

OCCUPANT NUMBER (columns 13-14)

Record the occupant number as shown in columns 13 and 14 on page OC-1. A separate page IC-2 must be completed for each occupant, and more than one page IC-2 may be used for a particular occupant if necessary. If, however, the occupant has NO injuries, page IC-2 should be left blank and the notation "not injured" written across the page.

INJURY NUMBER (columns 15-16)

For the purposes of the UMIVOR, an "injury" is defined as being all the significant pathological changes to a body region caused by:

- 1) an occupant's particular contact with some component of the Case Vehicle or with some other object; or
- 2) trauma not directly related to contact, but related to impact force (such as cervical strain from neck flexion upon impact).

Each injury is assigned its own "injury number." These numbers must be assigned and recorded on this page (and any necessary supplemental pages) sequentially, starting with "01."

¹⁵Marsh, J. C., "Existing Traffic Accident Injury Causation Data Recording Methods and the Proposal of an Occupant Injury Classification Scheme," Proceedings of the Sixteenth Conference of the American Association for Automotive Engineers. Also: Marsh, J. C., An Occupant Injury Classification Procedure Incorporating the Abbreviated Injury Scale. For a complete bibliographic listing, see the ANNOTATED BIBLIOGRAPHY.

Injuries need not be prioritized (for instance, by severity or location) when assigning these numbers. Please recall, however, that "injury numbers" are also associated with specific injuries in the information about passenger compartment intrusions (column groups H or J on pages IT-3 and IT-4) previously entered. The "injury number" recorded there should be the same as that which is used here on page IC-2.

Although a separate line must be used for each injury, a single injury may involve trauma to more than one organ in a particular region or in adjacent regions.

For example, trauma to the chest area from contact with the steering wheel might have caused fractured ribs, and a lacerated lung. These OIC's should be coded on the same line, with the steering wheel listed as the contact code.

However, in order to link injuries with injury sources (contact areas), trauma to a body region due to different contacts must be coded as separate injuries on separate lines. For example, a driver sustaining two facial lacerations, one from the steering wheel and one from the windshield, would have two OIC's on two different lines, each with its appropriate contact code(s).

A single injury is usually confined to a single body region. Thus all OIC's on one line usually have the same body-region code. However, an injury could overlap two or more body regions. For example, a passenger who struck the right A-pillar might have dislocated his shoulder and bruised his upper arm. Thus the injury would consist of two OIC's (SRDJ-3 and ARCI-1) on the same line.

AREA(S) OF POSSIBLE CONTACT (columns 17-20)

Up to two contact codes may be used to describe the possible agents of that injury's causation. Record these in the order of probability. However, if more than one agent of injury is known to have been involved, then the injury must be assigned different "injury numbers" and entered on different injury lines with each contact source coded.

For example, a forehead contusion suggested by occupant kinematics to have been caused by the windshield (12), but possibly caused instead by contact with the header (10) both contacts should be listed on the same line in order of probability, if possible.

Conversely, if the windshield AND the header were both known to cause forehead contusions, two separate injuries should be coded on two separate lines -- each with its own contact codes.

In another example, if the occupant's knee and foot were jammed against the instrument panel and floor during impact, and a fractured tibia occurred from the resulting flexion, both the floor and the instrument panel should be coded as injury-producing contacts for the fracture.

If only one possible area of contact is recorded for a particular injury, leave the entry for the remaining possible contact area blank.

PRIMARY OCCUPANT INJURY CLASSIFICATION

The OIC is a series of independently defined classification facets which are combined as a sequence of alphanumeric characters to describe an injury in the following terms:

Body Region
Aspect
Diagnosis of Lesion
Body System/Organ
Severity

First OIC Letter: **BODY REGION** (column 21)

"Body Regions" are defined as subsets of the body surface (such as chest, abdomen, and head) and all systems or organs within that region.

The one significant difference occurs in the pelvic region. Only the pelvic bones (sacrum, coccyx, and joint), the posterior muscles, and the tissues covering them are included in the pelvic body region (P). Internal organs in the pelvic structure are included instead in the abdominal body region (M).

The following codes are used for the Body Region entry:

H	Head(Skull,Scalp,Ears)	C	Chest(Anterior and Posterior Ribs)
F	Face(Forehead,Nose,Lips Mouth)	M	Abdomen(Diaphragm and below)
N	Neck(Cervical Spine, C1 - C7)	P	Pelvis-Hip
S	Shoulder(Clavicle, Scapula,Joint)	Y	Lower Extremities
X	Upper Extremities	T	Thigh
A	Arm (upper)	K	Knee
E	Elbow	L	Leg (below knee)
R	Forearm	Q	Ankle-Foot (toes)
W	Wrist-Hand (fingers)	O	Whole Body
B	Back	U	Unknown

Second OIC Letter: **ASPECT** (column 22)

The Aspect codes provide a means of more specifically locating the injury within the body region (such as: cervical injury, neck posterior [NP]). To insure consistent coding, only certain Aspect codes are permitted for each body region.

Because only a single aspect code may be used to describe each injury, some information may be lost. A fractured posterior rib on the left side of the chest should be coded "chest left" (CL). The fact that the rib was posterior is lost information; posterior (P) and anterior (A) are not valid aspect codes for the "chest" body region.

Similarly, a contusion to the calf of the left leg should be coded "leg, left" (LL). This would indicate the injury was in the left lower leg, but the information that the injury was to the posterior portion of that leg will be lost; posterior (P) and anterior (A) are not valid aspect codes for the extremities.

The following general Aspect codes are used, but see the Appendix (OIC Codes and Valid Combinations) for the specific permissible region/aspect combinations.

R	Right	P	Posterior/Back
L	Left	S	Superior/Upper
B	Bilateral	I	Inferior/Lower
C	Central	W	Whole Region
A	Anterior/Front	U	Unknown

Third OIC Letter: **DIAGNOSIS OF LESION** (column 23)

This letter is intended primarily to code diagnostic information concerning pathological changes. The following Diagnosis of Lesion codes are used:

A	Abrasion	P	Perforation, Puncture
B	Burn	R	Rupture
C	Contusion	S	Sprain
D	Dislocation	T	Strain
E	Severance, Transection	V	Avulsion
F	Fracture	O	Other
G	Detachment, Separation	U	Unknown
K	Concussion	Z	Fracture with dislocation
L	Laceration		
M	Amputation		
N	Crush		

Fourth OIC Letter: **SYSTEM/ORGAN** (column 24)

This letter describes the specific body system or organ affected. These categories are based on major body systems, rather than on the myriad of individual organs which exist.

The following codes may be used for the System/Organ entry:

A	Arteries, Veins	M	Muscles
B	Brain	N	Nervous system
C	Spinal cord	O	Eyes
D	Digestive	P	Pulmonary, Lungs
E	Ears	Q	Spleen
G	Urogenital	R	Respiratory
H	Heart	S	Skeletal
I	Integumentary	T	Thyroid, Other Endocrine glands
J	Joints	V	Vertebrae
K	Kidneys	W	All systems in region
L	Liver	U	Unknown

Fifth OIC Element: **SEVERITY** (column 25)

The last element of the OIC is the Abbreviated Injury Scale (AIS-85)¹⁶ severity code. The following codes are used:

0	None	4	Severe
1	Minor	5	Critical
2	Moderate	6	Maximum
3	Serious	9	Unknown

GENERAL COMMENTS ABOUT THE "OIC"

The combination of four letters and one number describes the particular injury and its severity.

For example, "NPCC-3" indicates "neck" (N), "posterior" (P), "contusion" (C), "spinal cord" (C); a contused spinal cord in the cervical spine.

For another example, "MRLK-4" indicates "abdomen" (M), "right" (R), "laceration" (L), "kidney" (K); an unspecified laceration to the right kidney.

The OIC dictionary contained in the Injury Coding Manual¹⁷ can be used to facilitate coding.

ASSOCIATED "OIC" (columns 26-30)

When there are several different lesions in one location resulting from contact with a particular vehicle component or object, one additional OIC can be recorded on that line.

The first OIC should be a diagnosis of damage at the deepest level. The subsequent "associated OIC" should be used to describe associated traumatic conditions. For instance, if a fractured rib punctured a lung, the lung lesion would be the primary OIC, and the rib fracture would be the associated OIC.

If any portion of an associated OIC is entered, the entire OIC should be completed.

¹⁶The Abbreviated Injury Scale (1985 Revision). For a complete bibliographic listing, see the ANNOTATED BIBLIOGRAPHY.

¹⁷Petrucelli, Elaine et al. See: ANNOTATED BIBLIOGRAPHY.

OTHER GENERAL COMMENTS ABOUT PAGE IC-2

Each line should be completed in turn and in its entirety (as appropriate, with blanks permitted in columns 19 and 20 and 26 through 30 as previously discussed). All spaces after the last line should be left blank.

SAMPLE CASE

A Sample Case was presented on pages 96 and 97 above, including a list of injuries and a copy of the Diagram Page (OC-3) as it should be completed.

On the next page is a copy of an Injury Classification Page (IC-2) as it should be completed for that Sample Case.

Duplicate columns 1-8 from the previous card.					Module <u> </u> <u> </u> <u> </u> <u> </u> 9 10		Format <u> </u> <u> </u> <u> </u> <u> </u> 11 12		INJURY CLASSIFICATION IC-2													
NOTE: Each line in the table below is a separate record (card). Duplicate columns 1 - 12 for each completed line.																						
OCCUPANT INJURY CLASSIFICATION																						
					PRIMARY OIC					ASSOCIATED OIC					COMMENTS							
PLACE CONTACTS IN ORDER OF PROBABILITY (HORIZONTALLY). START WITH MOST PROBABLE IN 1ST CONTACT AREA COLUMN. AREA(S) OF POSSIBLE CONTACT 1ST 2ND																						
13-14		15-16		17-18		19-20		COMMENTS					21 22 23 24 25					26 27 28 29 30				
<u>0</u> <u>1</u>	<u>0</u> <u>1</u>	<u>1</u> <u>4</u>	— —						<u>H</u> <u>W</u> <u>K</u> <u>B</u> <u>2</u>													
— —	<u>0</u> <u>2</u>	<u>2</u> <u>2</u>	— —						<u>H</u> <u>L</u> <u>L</u> <u>E</u> <u>1</u>													
— —	<u>0</u> <u>3</u>	<u>1</u> <u>4</u>	— —						<u>F</u> <u>L</u> <u>C</u> <u>Ø</u> <u>1</u>													
— —	<u>0</u> <u>4</u>	<u>1</u> <u>4</u>	— —						<u>F</u> <u>I</u> <u>F</u> <u>S</u> <u>2</u>													
— —	<u>0</u> <u>5</u>	<u>6</u> <u>5</u>	— —						<u>N</u> <u>A</u> <u>C</u> <u>R</u> <u>2</u>													
— —	<u>0</u> <u>6</u>	<u>6</u> <u>5</u>	— —						<u>C</u> <u>R</u> <u>L</u> <u>P</u> <u>3</u>	<u>C</u> <u>R</u> <u>F</u> <u>S</u> <u>3</u>												
— —	<u>0</u> <u>7</u>	<u>6</u> <u>5</u>	— —						<u>M</u> <u>S</u> <u>C</u> <u>I</u> <u>1</u>	<u>M</u> <u>S</u> <u>A</u> <u>I</u> <u>1</u>												
— —	<u>0</u> <u>8</u>	<u>2</u> <u>0</u>	— —						<u>E</u> <u>L</u> <u>D</u> <u>J</u> <u>2</u>													
— —	<u>0</u> <u>9</u>	<u>2</u> <u>2</u>	— —						<u>W</u> <u>L</u> <u>A</u> <u>I</u> <u>1</u>													
— —	<u>1</u> <u>0</u>	<u>6</u> <u>5</u>	— —						<u>P</u> <u>A</u> <u>F</u> <u>S</u> <u>3</u>													
— —	<u>1</u> <u>1</u>	<u>9</u> <u>8</u>	— —						<u>B</u> <u>I</u> <u>T</u> <u>M</u> <u>1</u>													
— —	<u>1</u> <u>2</u>	<u>5</u> <u>6</u>	<u>0</u> <u>0</u>						<u>K</u> <u>L</u> <u>L</u> <u>J</u> <u>3</u>													
— —	<u>1</u> <u>3</u>	<u>6</u> <u>5</u>	— —						<u>T</u> <u>R</u> <u>C</u> <u>I</u> <u>1</u>													
— —	<u>1</u> <u>4</u>	<u>2</u> <u>8</u>	<u>4</u> <u>0</u>						<u>Q</u> <u>R</u> <u>S</u> <u>J</u> <u>1</u>													
— —	— —	— —	— —						— —													
NOTE: USE ADDITIONAL PAGES IF NECESSARY.																						

Appendix: TEAM CODES

The TEAM CODE is a unique, two-digit numeric code assigned to each Investigating Team. This code should be entered in columns 1 and 2 on page AD-1. During the file-building process, this code is again duplicated in columns 1 and 2 on each subsequent data card.

These Codes were derived from those used on the CPIR (Collision Performance and Injury Report) Forms.

<u>Team Number</u>	<u>Team Name</u>
01	University of Michigan: Highway Safety Research Institute (NHTSA Project)
02	Baylor College of Medicine
03	Boston University
04	Calspan: III-A
05	Calspan: III-B
06	Ministry of Transport (Ottawa, Ontario)
07	Georgia Institute of Technology
08	University of Michigan: Highway Safety Research Institute (MVMA Project)
09	Indiana University
10	McGill University (Montreal, Quebec)
11	Miami University (Florida)
12	Maryland Medical/Legal Foundation
13	University of Montreal (Quebec): Ecole Polytechnique
14	University of New Brunswick
15	University of New Mexico
16	University of Michigan: Highway Safety Research Institute (Oakland County Project)
17	Ohio State University
18	University of North Carolina: Research Triangle Institute
19	University of Rochester
20	University of Southern California
21	Stanford Research Institute (2)
22	Stanford Research Institute (1)
23	Stanford University
24	Southwest Research Institute
25	University of California, Los Angeles: Trauma Research Group
26	Tulane University
27	University of California (Siegel)
28	University of Houston
29	University of Kentucky
	TEAM CODES (Concluded)

<u>Team Number</u>	<u>Team Name</u>
30	University of Michigan (Huelke)
31	University of Oklahoma
32	University of Toronto
33	University of Utah
34	University of Alberta
35	University of British Columbia
36	University of Manitoba
37	University of Saskatchewan
38	Nova Scotia Technical College
39	University of Western Ontario
40	NHTSA Accident Investigation Division
41	Dynamic Sciences, Inc.
42	University of Calgary
43	General Motors
44	Calspan Light Trucks
47	Arvin/Calspan, Washington, D.C.
50	National Traffic Safety Board (NTSB)

Appendix: STATE CODES

The following is a list of the State Codes assigned by the Federal Information Processing Standards.

<u>Name</u>	<u>Code</u>	<u>Name</u>	<u>Code</u>
Alabama	01	Nebraska	31
Alaska	02	Nevada	32
Arizona	04	New Hampshire	33
Arkansas	05	New Jersey	34
California	06	New Mexico	35
Colorado	08	New York	36
Connecticut	09	North Carolina	37
Delaware	10	North Dakota	38
District of Columbia	11	Ohio	39
Florida	12	Oklahoma	40
Georgia	13	Oregon	41
Hawaii	15	Pennsylvania	42
Idaho	16	Rhode Island	44
Illinois	17	South Carolina	45
Indiana	18	South Dakota	46
Iowa	19	Tennessee	47
Kansas	20	Texas	48
Kentucky	21	Utah	49
Louisiana	22	Vermont	50
Maine	23	Virginia	51
Maryland	24	Washington	53
Massachusetts	25	West Virginia	54
Michigan	26	Wisconsin	55
Minnesota	27	Wyoming	56
Mississippi	28		
Missouri	29	Non-USA or Canada	99
Montana	30	Unknown USA	00

CANADIAN PROVINCES

Alberta	81	Ontario	88
British Columbia	82	Prince Edward Island	89
Manitoba	83	Quebec	90
New Brunswick	84	Saskatchewan	91
Newfoundland	85	Yukon	92
Northwest Territory	86		
Nova Scotia	87	Unknown Canada	80

Appendix: **MANUFACTURER/BODY AND MAKE/MODEL CODES**

THE MAKE/MODEL CODES HAVE BEEN REPLACED BY THE FOUR-DIGIT SERIES NAME CODES TO MORE ACCURATELY DESCRIBE THE ACTUAL MAKE AND MODEL OF THE VEHICLE BEING INVESTIGATED. THEY APPEAR LATER IN THIS APPENDIX. LISTED BELOW ARE THE MANUFACTURER/BODY CODES, WHICH REPRESENT A FIVE-DIGIT CODE FORMERLY CALLED MAKE/MODEL.

MANUFACTURER/BODY CODE

The Man/Body Code consists of five digits which identify the described vehicle by the country, corporation, and division of its manufacture, and by its general body type and size (wheelbase). It was originally developed for use in conjunction with the General Motors Corporation Accident Investigation "Long Form," which subsequently evolved into the "Collision Performance and Injury Report" (CPIR).

The Man/Body Code's five-digit sequence consists of three basic elements. The first element, a single digit, identifies the country of manufacture. The following code values have been assigned:

1	United States	6	Germany
2	Canada	7	Italy
3	Australia	8	Japan
4	England	9	Other (Korea, etc)
5	France	0	Unknown

This value should be determined by the actual country of its manufacture, not by the "home country" of its manufacturing corporation.

The second element of the Man/Body Code consists of the second and third digits, and identifies the corporation and division of the manufacturer. For all countries, certain corporation-code-value ranges have been reserved:

00	Unknown, or missing data
01-09	(not specifically reserved)
10-19	General Motors Corporation
20-29	Ford Motor Company
30-39	Chrysler Corporation
40-49	American Motors Corporation
50-59	Other USA Manufacturers
60-69	USA Truck Manufacturers
70-79	USA Special Vehicle Manufacturers
80-89	Foreign Mfrs. in USA
90-99	(not specifically reserved)

On this and the following page are listed the individual country/corporation/division code combinations which are currently assigned.

1 U.S.A.

- | | |
|---|-------------------------|
| 11 General Motors Corporation | |
| 111 Buick | 115 Pontiac |
| 112 Cadillac | 116 GMC Truck and Coach |
| 113 Chevrolet | 117 GMC Electromotive |
| 114 Oldsmobile | |
| 12 Ford Motor Company | |
| 121 Ford | 122 Lincoln-Mercury |
| 13 Chrysler Corporation | |
| 131 Chrysler | 134 Plymouth |
| 132 Dodge | 135 DeSoto |
| 133 Imperial | |
| 14 American Motors Corporation | |
| 141 A.M.C. (Passenger-Car Division) | |
| (152 Jeep,Jeep-Eagle) | (561 Renault) |
| 15 Other U.S.A. Passenger-Vehicle Manufacturers | |
| 151 Checker | 155 Harley-Davidson |
| 152 Kaiser/Jeep | 156 General Vehicles |
| 153 International(use
also for Int Harv
and Navistar) | (Bricklin) |
| 154 Studebaker/Avanti | 157 Chevrolet - Nummi |
| | 158 Diamond-Star Motors |
| 16-17 U.S.A. Truck and Other-Type Vehicle Manufacturers | |
| 160 Unknown | 168 Other U.S.A. Truck |
| 161 Brockway | Corporations |
| 162 Diamond-Reo | 170 Other USA Unknown |
| 163 FWD | Special Veh.Man. |
| 164 Kenworth | 171 Flexible |
| 165 Mack | 172 Freuhauf |
| 166 Peterbuilt | 173 Freightliner |
| 167 White (including
Autocar) | |
| 18 U.S.A. Manufacturing by Foreign Corporations | |
| 181 Volkswagon of America | |
| 182 Honda/America | 184 Mazda/America |
| 183 Toyota/America | 185 Nissan/America |

2 Canada

- | | |
|----------------------------------|---------------------|
| 21 GM/Canada | |
| 213 Chevrolet | 215 Pontiac |
| 214 Oldsmobile | |
| 22 Ford/Canada | |
| 221 Ford/Canada | 222 Lincoln-Mercury |
| 23 Chrysler/Canada | |
| 231 Chrysler Canada, Ltd. | 235 G.M.C. Canada |
| 232 Dodge Canada | 236 Eagle Canada |
| 234 Plymouth Canada | |
| 24 Asian Manufacturers/Canada | |
| 241 Honda/Canada | |
| 25 European Manufacturers/Canada | |
| 251 Volvo/Canada | |

- 26 Other Canadian Manufacturers
 - 260 Unknown Canadian Truck Corporation
 - 268 Other Canadian Truck Corporation
- 27 Freightliner
 - 273 Freightliner
- 3 Australia
 - 31 GM/Australia
 - 317 Holden
- 4 England
 - 41 GM/England
 - 419 Vauxhall
 - 42 Ford/England
 - 421 Ford/England
 - 43 Chrysler/England
 - 434 Plymouth (Cricket)
 - 436 Sunbeam
 - 45 British Leyland
 - 451 Austin
 - 452 Austin Healey
 - 453 MG
 - 454 Morris
 - 455 Jaguar/Daimler
 - 456 Triumph
 - 457 Sterling
 - 458 Rover
 - 459 Bently
 - 46 Rootes
 - 461 Rootes
 - 48 Other English Manufacturers
 - 481 Aston Martin
 - 482 Lotus Elan
 - 484 Rolls Royce
 - 486 Jensen,
 - Jensen-Healey
 - 489 Norton (Motorcycle)
- 5 France
 - 53 Chrysler/France
 - 531 Simca
 - Other French Manufacturers
 - 551 Citroen
 - 561 Renault
 - 571 Peugeot
- 6 Germany
 - 61 GM/Germany
 - 618 Opel
 - 62 Ford/Germany
 - 621 Fiesta
 - 622 Capri
 - Other German Manufacturers
 - 651 Mercedes Benz
 - 661 Volkswagon
 - 662 Porsche
 - 671 BMW
 - 681 Audi

- 7 Italy
 - 72 Ford of Italy
 - 722 Ford of Italy
 - Other Italian Manufacturers
 - 751 Alfa-Romeo
 - 761 Fiat
 - 771 Ferrari
 - 781 Maserati
 - 782 Lancia
 - 784 Lamborghini
- 8 Japan
 - 81 GM/Japan
 - 813 Chevrolet-Isuzu (LUV Pickup)
 - 819 Chevrolet-Mitsubishi
 - 82 Ford/Japan
 - 821 Ford Courier
 - 822 Mercury
 - 83 Chrysler/Japan
 - 832 Dodge-Mitsubishi (Colt)
 - 834 Plymouth-Mitsubishi (Champ, Arrow, Sappore)
 - Other Japanese Manufacturers
 - 851 Toyo (Mazda)
 - 852 Mitsubishi
 - 853 Isuzu
 - 861 Nissan (Datsun)
 - 871 Toyota
 - 881 Honda
 - 882 Fuji Heavy Industries (Subaru)
 - 883 Suzuki
 - 884 Kawasaki
 - 885 Yamaha
- 9 Other Foreign
 - 93 Korea
 - 931 Daewoo/GM
 - 932 Ford/Kia Motors
 - 939 Hyundai
 - 94 Mexico
 - 941 General Motors
 - 942 Ford/Mercury
 - 943 Chrysler
 - 95 Sweden
 - 951 Saab
 - 952 Volvo
 - 99 Yugoslavia
 - 997 Yugo

The third element of the Man/Body Code, consisting of the fourth and fifth digits, identifies the general type of vehicle body, and (for some cases) its wheelbase, net load-carrying capability, or engine size.

The following Table gives the two-digit codes which are assigned to conventional passenger-car body types.

TABLE 5
PASSENGER-CAR MAN/BODY-CODE SUFFIXES

Size Category	Code Designation	Wheelbase Limits in centimeters [in inches]	
		Minimum	Maximum
Sub-mini	24	no minimum	<228.6 [<90]
Mini	25	228.6 [90]	241 [94.9]
Subcompact	26	241.5 [95]	253.7 [99.9]
Compact	27	254 [100]	266.4 [104.9]
Intermediate	28	266.7 [105]	279.1 [109.9]
Full-Standard	29	279.4 [110]	291.8 [114.9]
Large	02	292.1 [115]	317.2 [124.9]
Limousine	03	317.5 [125]	no maximum

When the Man/Body Code was developed in the early 1970's, it was "locked into" this association between wheelbase and "size category." Since then, many U.S.-built automobile lines have been downsized, and a disproportionately large number now fall into the "subcompact/mini" category, according to the above Table.

The code values shown in the above Table are admittedly somewhat arbitrary. In the absence of more definitive criteria to distinguish between them, these code values are to be used until further clarification from the Motor Vehicle Manufacturers Association and its affiliated members have provided more definitive definitions.

For vehicles other than conventional passenger cars, the following third-element code values have been assigned.

MULTIPURPOSE PASSENGER VEHICLE

- 11 Passenger van; panel or cargo van
- 14 Short wheelbase (<271.8 cm [107 in]) utility vehicle (Jeep, Bronco)
- 15 Long wheelbase (>271.8 cm [107 in]) utility vehicle (Carrall, Suburban); panel truck
- 21 Motor home

TRUCK:

- 11 Panel or cargo van; passenger van
- 12 Pickup truck (no canopy or shell)
- 13 Unknown light truck (<1361 Kg [1.5 tons] net carrying capacity)
- 15 Panel truck; long wheelbase (>271.8 cm [107 in]) utility vehicle (Carrall, Suburban)
- 16 Pickup truck with canopy or shell cover
- 17 Pickup car with or without canopy or shell cover
- 22 Pickup truck with slide-in camper
- 30 Unknown truck type or net carrying capacity
- 31 Cab with chassis-mounted camper
- 33 Walk-in type delivery van
- 34 Straight truck
- 35 Truck-tractor alone ("bobtail")
- 36 Chassis cab (alone)
- 37 Unknown heavy truck (>1361 Kg [1.5 tons] net carrying capacity)
- 38 Truck-tractor with semitrailer (but no full trailer or "pup")
- 39 Truck or truck-tractor with full trailer(s) (with or without a semitrailer)

BUS:

- 40 Unknown bus type
- 41 School bus
- 42 Inter-city bus, highway coach
- 43 Intra-city bus, transit bus
- 44 Streetcar (with tracks)

MOTORCYCLE:

- 50 Unknown motorcycle type; unknown motorcycle engine displacement}

Two-wheeled (without sidecar)

- 51 1-75 cm³ engine displacement
- 52 76-125 cm³ engine displacement
- 53 126-250 cm³ engine displacement
- 54 251-500 cm³ engine displacement
- 55 501-750 cm³ engine displacement
- 56 ≥751 cm³ engine displacement

Three-wheeled (or two-wheeled with sidecar)

- 57 Any engine displacement

SPECIAL PURPOSE VEHICLE:

- 60 Unknown or other special purpose vehicle
- 61 Snowmobile
- 62 All-terrain vehicle ("ATV")
- 63 Amphibious vehicle
- 64 Farm vehicle
- 65 Construction vehicle
- 66 Camping trailer
- 67 Cargo trailer; truck trailer
- 68 Railroad car (except locomotive)
- 69 Railroad locomotive, switching engine

UNKNOWN:

- 99 Unknown type of vehicle

Note that the third element of the Man/Body Code is the same as the "Object Contacted" code given on page DA-4 of the UMIVOR.

MAKE/MODEL CODE

The Make/Model Code consists of two elements. The first two digits identify the make. The second two digits identify the specific series or model name within that particular manufacturer's production.

For both code elements, the "unknown" code is "99." The "known but no code assigned" code is "98."

The first-element code values shown below have been assigned to specific manufacturers.

01 Chevrolet	17 Capri	33 Plymouth Trk
02 Ford	18 Mazda	34 Jeep
03 Pontiac	19 Fiat	35 International
04 Buick	20 Volvo	Harvester
05 Plymouth	21 Audi	36 Eagle
06 Oldsmobile	22 Mitsubishi	40 Renault
07 Dodge	23 Honda	41 Suzuki
08 Volkswagen	24 Porsche	42 Mercedes
09 Mercury	25 MG	43 Isuzu
10 Cadillac	26 Subaru	45 Acura
11 AMC	27 Arrow	46 Peugeot
12 Chrysler	28 GM/Canada	50 BMW
13 Lincoln	29 Chev Truck	81 Large Truck
14 Opel	30 GMC Truck	90 Large Bus
15 Datsun	31 Ford Truck	
16 Toyota	32 Dodge Truck	

The specific codes for the combined first and second elements for each of these manufacturers are given on the following pages. With the ever increasing addition of new models (and lately, of new manufacturers) this list is not obviously, all inclusive. Attempts will be made to update this list as new models

are introduced (and become known). Use the "98" code (for the last two digits) for a model which may not appear on this listing. This will alert the editor to assign a valid new code and update the existing list.

01: Chevrolet (Passenger Car)

0110	Beretta	0134	GEO Prism
0111	Belair	0141	Impala
0112	Biscayne	0142	Kingswood
0113	Brookwood	0143	Laguna
0118	Cavalier	0151	Monte Carlo
0119	Celebrity	0152	Monza
0120	Chevy II	0153	Malibu
0121	Camaro	0161	Nova
0122	Caprice	0162	Nomad
0123	Chevelle, DeLuxe	0165	Spectrum
0124	Corvair	0166	Super Sport
0125	Corvette	0167	Sprint
0126	Chevette	0171	Townsmen
0127	Concours	0181	Vega, Vega Kammback, Vega Express
0129	Citation	0198	Uncoded Chevrolet
0130	Corsica	0199	Unknown Chevrolet
0131	El Camino		
0132	Greenbrier		

02: Ford (Passenger Car)

0210	Cobra	0241	LTD
0211	Country Sedan	0242	LTD II
0212	Custom 500, Custom Ranch, Ranch Wagon	0243	Maverick, Grabber
0214	Country Squire	0244	Mustang, Mustang II
0217	Crown Victoria	0251	Pinto
0219	Escort	0255	Probe
0220	EXP	0261	Ranchero
0221	Elite	0270	Tempo
0222	Falcon	0271	Thunderbird
0223	Festiva	0272	Torino
0224	Fairlane	0275	Taurus
0225	Fairmont/Futura		
0226	Fiesta		
0231	Galaxie	0298	Uncoded Ford
0233	Granada	0299	Unknown Ford

03: Pontiac

0310 A-6000	0342 LeMans, Safari
0311 Astre	0346 Phoenix
0312 Bonneville	0350 Starchief
0313 Catalina, Safari	0351 Sunbird
0321 Firebird	0355 Tempest
0322 Executive	0356 T-1000
0325 Fiero	0361 Ventura
0331 Grand Am	0371 2+2
0332 Grand Lemans	
0333 Grand Prix	
0335 Grandville	
0336 GTO	0398 Uncoded Pontiac
0340 J-2000/2000	0399 Unknown Pontiac

04: Buick

0411 Apollo	0451 Riviera
0421 Centurion	0452 Regal (Sumerset)
0422 Century	0461 Skyhawk
0431 Electra 225	0462 Skylark
0432 Estate (Wagon)	0463 Special
0433 Gran Sport	0464 Sport, Sportwagon
0441 LeSabre, Custom, and Luxus	0471 Wildcat
0449 Park Avenue	0498 Uncoded Buick
	0499 Unknown Buick

05: Plymouth

0500 Acclaim	0533 Sebring
0501 Barracuda	0534 Signet
0502 Belvedere	0535 Sport
0503 Cricket	0536 Sundance
0504 Caravelle	0537 Sapporo
0505 Custom	0541 Valiant, Scamp
0510 Fury (I, II, III)	0542 Duster
0523 Grand Fury, Sedan, Coupe, Custom, Brougham	0544 VIP
0526 GTX	0551 Volare
0527 Horizon	0570 Turismo/TC-3
0529 Reliant	0580 Arrow
0530 Road Runner	0583 Champ
0531 Satellite	0584 Colt
0532 Suburban	0585 Conquest
	0598 Uncoded Plymouth
	0599 Unknown Plymouth

06: Oldsmobile

0603	Cutlass Calais	0642	Omega
0605	Cutlass Ciera	0651	Starfire
0611	Custom Cruiser	0652	Supreme, Cutlass Supreme
0612	Cutlass	0653	Super 88
0621	Delmont 88	0661	Toronado
0622	Delta 88	0671	Vista Cruiser
0623	Dynamic 88	0681	442
0625	F-85, F-87		
0627	Firenza	0698	Uncoded Oldsmobile
0631	Jetstar	0699	Unknown Oldsmobile
0641	Ninety Eight, 98		

07: Dodge (Passenger Car)

0710	Aries	0742	Omni
0711	Aspen	0743	Mirada
0721	Challenger	0745	Lancer
0722	Charger	0751	Polara
0723	Coronet	0761	Royal Monaco
0724	Custom	0762	St. Regis
0730	Daytona	0765	Shadow
0731	Dart, Swinger, Demon and Dart Sport	0770	024
0738	Diplomat	0774	400
0740	Magnum XE	0776	600
0741	Monaco	0784	Colt
		0798	Uncoded Dodge
		0799	Unknown Dodge

08: Volkswagen

0811	Beetle	0863	Type 3 Squareback
0821	Commercial	0865	Transporter
0831	Dasher	0871	411
0832	Jetta	0872	412
0835	Golf	0881	1200
0837	GTI	0882	1300
0841	Karmann Ghia	0883	1500
0842	Van	0890	Vanagon
0847	Quantum		
0850	Rabbit Pickup	0898	Uncoded Volkswagen
0851	Rabbit	0899	Unknown Volkswagen
0852	Scirocco		
0861	The Thing		
0862	Type 3 Fast Back		

09: Mercury

0911	Bobcat	0947	Monterey
0912	Brougham	0949	Meteor
0913	Caliente	0950	Montclair
0914	Capri (U.S.)	0951	Rideau
0915	Colony Park	0953	S-55
0916	Commuter	0955	Parklane
0921	Comet	0959	Sable
0922	Cougar	0962	Villager
0923	Cyclone	0963	Voyager
0929	Grand Marquis	0964	Zephyr
0931	Lemoyne	0970	Topaz
0935	LN7	0976	Tracer
0938	Lynx	0981	202
0941	Marauder		
0942	Marquis		
0943	Monarch		
0944	Montcalm	0998	Uncoded Mercury
0945	Montego	0999	Unknown Mercury

10: Cadillac

1001	Allante	1051	Seville
1011	Calais		
1012	Commercial		
1015	Cimarron		
1021	DeVille	1098	Uncoded Cadillac
1031	Eldorado	1099	Unknown Cadillac
1041	Fleetwood 60 and Fleetwood Brougham		
1042	Fleetwood 75		

11: American Motors Corporation (Passenger Car Division)

1111	Ambassador, DPL	1131	Hornet
1112	AMX	1141	Javelin
1113	American, Rambler/American, Rogue	1151	Marlin
1114	Classic, Rambler/Classic	1152	Matador
1115	Concord	1161	Pacer
1117	Eagle	1172	Rebel
1119	Encore	1174	Spirit
1121	Gremlin	1180	Alliance
		1198	Uncoded AMC
		1199	Unknown AMC

12: Chrysler

1211	300	1241	New Yorker, Fifth Avenue, New Yorker Brougham
1221	Cordoba	1242	Newport, Newport Custom
1222	Crown	1261	Town and Country
1227	E-Class	1298	Uncoded Chrysler
1229	Gran LeBaron	1299	Unknown Chrysler
1231	Imperial		
1234	Laser		
1235	LeBaron, Imperial LeBaron		

13: Lincoln

1311	Continental	1323	Mark V
1315	Versailles	1324	Mark VI
1320	Mark II	1325	Mark VII
1321	Mark III	1340	Town Car
1322	Mark IV	1398	Uncoded Lincoln
		1399	Unknown Lincoln

14: Opel

1411	1900	1451	Manta
1421	Coupe	1452	Rallye
1425	Deluxe	1453	Sedan
1431	GT	1461	Sport Coupe
1432	Corsa	1462	Sport Sedan
1441	Kadett	1463	Station Wagon
1442	Luxus	1498	Uncoded Opel
		1499	Unknown Open

15: Datsun/Nissan

1510	510	1541	B-210
1511	610	1542	PL411
1512	710	1543	PL510
1513	810	1544	F10
1521	1200	1557	Infiniti
1522	1600	1560	Pulsar
1523	2000	1571	Sentra
1530	200SX	1575	Stanza
1531	240/60/810	1591	Short Pickup
1532	240Z	1592	Long Pickup
1533	260Z	1598	Uncoded Datsun
1534	280Z	1599	Unknown Datsun
1536	300ZX		

16: Toyota

1610	Camry	1621	Land Cruiser
1611	Carina	1631	Mark II
1612	Celica	1680	Tercel
1613	Corolla	1691	Short Pickup
1614	Corona	1692	Long Pickup
1615	Crown	1698	Uncoded Toyota
1616	Cressida	1699	Unknown Toyota

17: Ford of Europe

1711	Capri Sport Coupe	1798	Uncoded European Ford
1750	Merkur XR4Ti	1799	Unknown European Ford
1770	Sierra XR4i		

18: Mazda (Toyo)

1811	808	1834	626
1812	1300	1835	GLC
1813	1600	1857	RX7
1821	Custom Coupe	1891	B1600 Pickup
1823	323	1892	Rotary Pickup
1831	RX-2		
1832	RX-3	1898	Uncoded Mazda
1833	RX-4	1899	Unknown Mazda

19: Fiat

1911	124	1931	X V9
1912	128	1998	Uncoded Fiat
1913	131	1999	Unknown Fiat
1921	850 Spider		

20: Volvo

2011	140	2030	242DL
2012	142	2031	240
2013	144	2032	260
2014	145	2033	245DL
2021	160	2041	1800
2022	164E	2098	Uncoded Volvo
		2099	Unknown Volvo

21: Audi

2111	100 GL Fox	2189	Quattro
2112	100LS	2190	5000
2121	Fox	2198	Uncoded Audi
		2199	Unknown Audi

22: Mitsubishi

2290 Uncoded Mitsubishi
2299 Unknown Mitsubishi

23: Honda

2311 Accord	2324 Prelude
2321 Civic	2398 Uncoded Honda
2322 Civic CRX	2399 Unknown Honda
2323 Civic CVCC	

24: Porsche

2411 911	2435 924
2412 911 Targa	2441 Turbo Carrera
2421 912 Coupe	2498 Uncoded Porsche
2431 914 Roadster	2499 Unknown Porsche

25: MG

2511 Midget	2598 Uncoded MG
2512 MGB	2599 Unknown MG
2513 MGB/GT	

26: Subaru

2611 DL	2631 STD
2621 G	2641 4WD
2622 GF	2698 Uncoded Subaru
2623 GL	2699 Unknown Subaru

27: Arrow

2711 Arrow Hatchback	2798 Uncoded Arrow
2712 Mini Pickup	2799 Unknown Arrow

28: GM/Canada

2811 Acadian	2851 Parisienne
2812 Astre	2861 Strato Chief
2821 Beaumont	2871 Astre Panel Truck
2831 Gr Parisienne	2898 Uncoded GM/Canada
2841 Laurentian	2899 Unknown GM/Canada

29: Chevrolet Truck

2901	1/2T Chassis Cab	2913	3/4T Sport Van
2902	1/2T Fleetside	2914	1T Cutaway, Hi-cube
2903	1/2T Suburban	2915	1T Chevy Van
2904	C/K Blazer	2916	1T Sport Van
2905	3/4T Chassis Cab	2917	LUV Pickup
2906	3/4T Fleetside	2920	S-10/T-10 Pickup
2907	3/4T Suburban	2925	M-10 Astro Van
2908	1T Chassis Cab	2933	S/T Blazer
2909	1T Fleetside	2960	Chevrolet 6000
2910	1/2T Chevy Van		
2911	1/2T Sport Van	2998	Uncoded Chevy Truck
2912	3/4T Chevy Van	2999	Unknown Chevy Truck

30: GMC Truck

3001	1/2T Chassis Cab	3018	160 Motorhome
3002	1/2TFender/wideside	3019	Classic Sprint
3003	1/2T Suburban	3020	S-15/T-15 Pickup
3004	Jimmy (C/K Jimmy)	3021	Caballero
3005	3/4T Chassis Cab	3022	Diable
3006	3/4TFender/wideside	3023	Handi Bus
3007	3/4T Suburban	3024	Handi Van
3008	1T Chassis Cab	3025	Panel
3009	1T Fender/wideside	3030	M-15 Safari Van
3010	1/2T Vandura	3033	S/T Jimmy
3011	1/2T Rally Wagon	3060	6000 Truck
3012	3/4T Vandura	3091	Brigadier
3013	3/4T Rally Wagon	3093	General
3014	1T Cutaway Van	3095	D9K064 Astro Truck Tractor
3015	1T Vandura	3098	Uncoded GMC Truck
3016	1T Rally Wagon	3099	Unknown GMC Truck
3017	140 Motorhome		

31: Ford Truck

3101	E-100 Club Wagon	3114	E-250 Econoline
3102	E-150 Club Wagon	3115	E-350 Econoline
3103	E-200 Club Wagon	3116	E-200 Econoline
3104	E-250 Club Wagon	3117	E-300 Econoline
3105	E-300 Club Wagon	3118	Courier
3106	E-350 Club Wagon	3120	Ranger R14
3107	F-100 Flareside	3125	Bronco II U14
3108	F-150 Flareside	3130	Aerostar
3109	F-250 Flareside		
3110	F-350 Flareside	3180	LTS-800 Salt Truck
3111	Bronco U15		
3112	E-100 Econoline	3198	Uncoded Ford Truck
3113	E-150 Econoline	3199	Unknown Ford Truck

32: Dodge Truck

3201	Sportsman 1/2 Ton	3210	1TSweptline,Utiline
3202	Sportsman 3/4 Ton	3212	D-50 Ram (Japan)
3203	Maxivan,wagon 3/4T	3213	Rampage Pickup
3204	Sportsman 1Ton	3216	1 3/4T Ram Van, B-350
3205	Maxivan,wagon 1Ton	3220	Caravan, Minivan
3206	4 x 4 Ramcharger	3225	Dakota PU
3207	4 x 2 Ramcharger	3230	Ram Raider
3208	1/2TSweptline,Utiline	3298	Uncoded Dodge Truck
3209	3/4TSweptline,Utiline	3299	Unknown Dodge Truck

33: Plymouth Truck

3301	Voyager 1/2 Ton	3306	4 x 4 Trail Duster
3302	Voyager 3/4 Ton	3307	4 x 2 Trail Duster
3303	Voyager 3/4T Maxi	3312	Horizon Pickup
3304	Voyager 1Ton	3320	Voyager II Minivan
3305	Voyager 1Ton Maxi	3398	Uncoded Plymouth Trk
		3399	Unknown Plymouth Trk

34: Jeep

3401	Jeepster, Commando	3411	DJ-6
3402	Wagoneer, J-100, Gladiator, Townside	3412	Unknown Jeep Truck
3403	J-10 Pickup short wheelbase (<310cm)	3413	CJ-5A
3404	J-20 Pickup long wheelbase (>310cm)	3414	DJ-5
3405	Cherokee	3415	CJ-6A
3406	CJ-6	3416	Unknown "Jeep" type
3407	CJ-5	3417	F4-134 (6-230)
3408	CJ-7	3418	Scrambler Pickup
3409	CJ-3B	3419	CJ-8, Scrambler
		3420	Comanche
		3498	Uncoded Jeep Vehicle
		3499	Unknown Jeep Vehicle

35: International Harvester/Transtar

3501	Scout F/E	3514	Pickup, Fender PU
3502	Scout Pickup	3515	Panel Body,Roadster
3503	Scout Traveltop	3516	SS II
3504	150 F/E	3517	Terra
3505	150 Pickup 1/2Ton	3518	Travelall other
3506	150 Travelall	3319	Traveler
3507	Travelall 1/2Ton	3320	Travelette
3508	3/4Ton Fender PU	3321	Utility
3509	Travelall 3/4 Ton	3522	XLC
3510	500 F/E	3571	S-series
3511	Bonus Load	3597	COF-9670 (Tractor)
3512	Cab Top	3598	Uncoded International
3513	Custom	3599	Unknown International

36: Eagle

3650 Medallion
3665 Premier

3680 Summit
3699 Unknown Eagle

40: Renault

4001 Fuego
4002 LeCar
4050 Medallion

4081 18i, Sportwagon
4098 Uncoded Renault
4099 Unknown Renault

41: Suzuki

4198 Uncoded Suzuki
4199 Unknown Suzuki

42: Mercedes-Benz

4219 190
4230 300
4242 420

4256 560
4298 Uncoded Mercedes
4299 Unknown Mercedes

43: ISUZU

4398 Uncoded Isuzu
4399 Unknown Isuzu

45: Acura

4501 Integra
4598 Uncoded Acura
4599 Unknown Acura

46: Peugeot

4601 304
4602 403
4603 404

4604 505/504
4698 Uncoded Peugeot
4609 Unknown Peugeot

50: BMW:

5001 Bavaria
5002 530C

5098 Uncoded BMW
5099 Unknown BMW

81: Large Truck

8106 Freightliner COE 6x4 Truck Tractor
8121 Kenworth K100E 6x4 COE Truck Tractor
8198 Uncoded Large Truck
8199 Unknown Large Truck

90: Large Bus

9001 Flexible Intracity (transit)
9002 Chevrolet Series 6000 Bus
9098 Uncoded Large Bus
9099 Unknown Large Bus

Appendix: **ENGLISH-TO-METRIC CONVERSIONS**

The following summary is provided to assist field investigators and others in converting the measurements requested in the UMIVOR from "English" to metric values.

(metric) equals	(English) times	(conversion factor)
LENGTH:		
millimeters (mm)	= inches	x (25.4)
meters (m)	= feet	x (0.3048)
kilometers (km)	= miles	x (1.609)
MASS (WEIGHT):		
kilograms (kg)	= pounds	x (0.4536)
kilograms (kg)	= tons	x (907.2)
PRESSURE:		
kilopascal (kPa)	= pounds/sq inch (psi)	x (6.895)
TEMPERATURE:		
degrees (Celsius)	= [degrees (Fahrenheit) - 32] x [5/9]	

Appendix: OPTIONAL DAMAGE PICTORIAL DIAGRAMS

On pages VD-3 and OV-2 of the UMIVOR Report are printed pictorial diagrams for a conventional four-door sedan. These diagrams should be used for recording the damage which occurred to the Case and Other Vehicles respectively.

For a Case or an Other Vehicle which has some other body style, one of the optional damage pictorial diagrams contained in this Appendix should be used instead. Photo-reproduce the most appropriate one, and insert it immediately following the respective page in the UMIVOR.

Optional damage pictorial diagrams for the types of vehicles listed below and on the next page have been included. A vehicle portrayed in one of the full-size diagrams (pages 131-159) may be either a Case or an Other Vehicle. One portrayed in a reduced-size diagram (pages 160-166) does not meet the criteria for being a Case Vehicle on a UMIVOR form, but may still be an Other Vehicle.

<u>Page Number</u>	<u>Vehicle Type</u> <u>Body Type</u>
	PASSENGER CAR
	Notchback or conventional
133	Two-door notchback coupe
134	Four-door notchback sedan (same as in UMIVOR)
135	Four-door sedan with rear or "opera" window"
	Fastback
136	Two-door fastback coupe
137	Two-door fastback coupe with wrap-around rear window
	Specialty or Sport
138	Two-door sport coupe
139	Two-door VW "Beetle"
	Hatchback
140	Two-door hatchback coupe (subcompact)
141	Four-door hatchback sedan (subcompact)
	Station wagon
142	Two-door station wagon
143	Four-door station wagon
	MULTI-PURPOSE PASSENGER VEHICLE
	Utility vehicle
144	Two-door (short-wheelbase) utility vehicle ("jeep"-type design)
145	Three-door (long-wheelbase) utility vehicle
	Pickup
146	Two-door conventional pickup truck (alone)

List of Optional Damage Pictorial Diagrams (Continued)

<u>Page Number</u>	<u>Vehicle Type</u> <u>Body Type</u>
147	Two-door pickup truck with canopy or shell
148	Two-door pickup car
149	Two-door pickup truck with extended cab (small window)
150	Two-door pickup truck with extended cab (large window)
151	Four-door pickup truck ("crew cab")
152	Pickup camper
153	General MPV/PU drawing
	Van
154	Cargo van
155	Forward-engine cargo van
156	Forward-engine passenger van with hinged side rear doors
157	Forward-engine passenger van with sliding side rear door
158	Hi-cube van
159	Cutaway van with motor home
160	Step-van
	TRUCK
	Straight truck
161	General straight-truck pictorial
162	Short-box straight truck
162	Long-box straight truck
163	Garbage truck
163	Motor home
	Tractor, articulated truck
164	Conventional tractor alone ("bobtail")
164	Cab-over-engine ("COE") tractor alone ("bobtail")
165	Conventional tractor with single-bottom semitrailer
165	Cab-over-engine ("COE") tractor with single-bottom semitrailer
166	Cab-over-engine ("COE") tractor with double-bottom trailers
166	Conventional tractor with single-bottom tanker semitrailer
	BUS
167	Forward-engine bus
167	Rear-engine bus
	RAILROAD LOCOMOTIVE
168	Streamliner
168	Switching engine

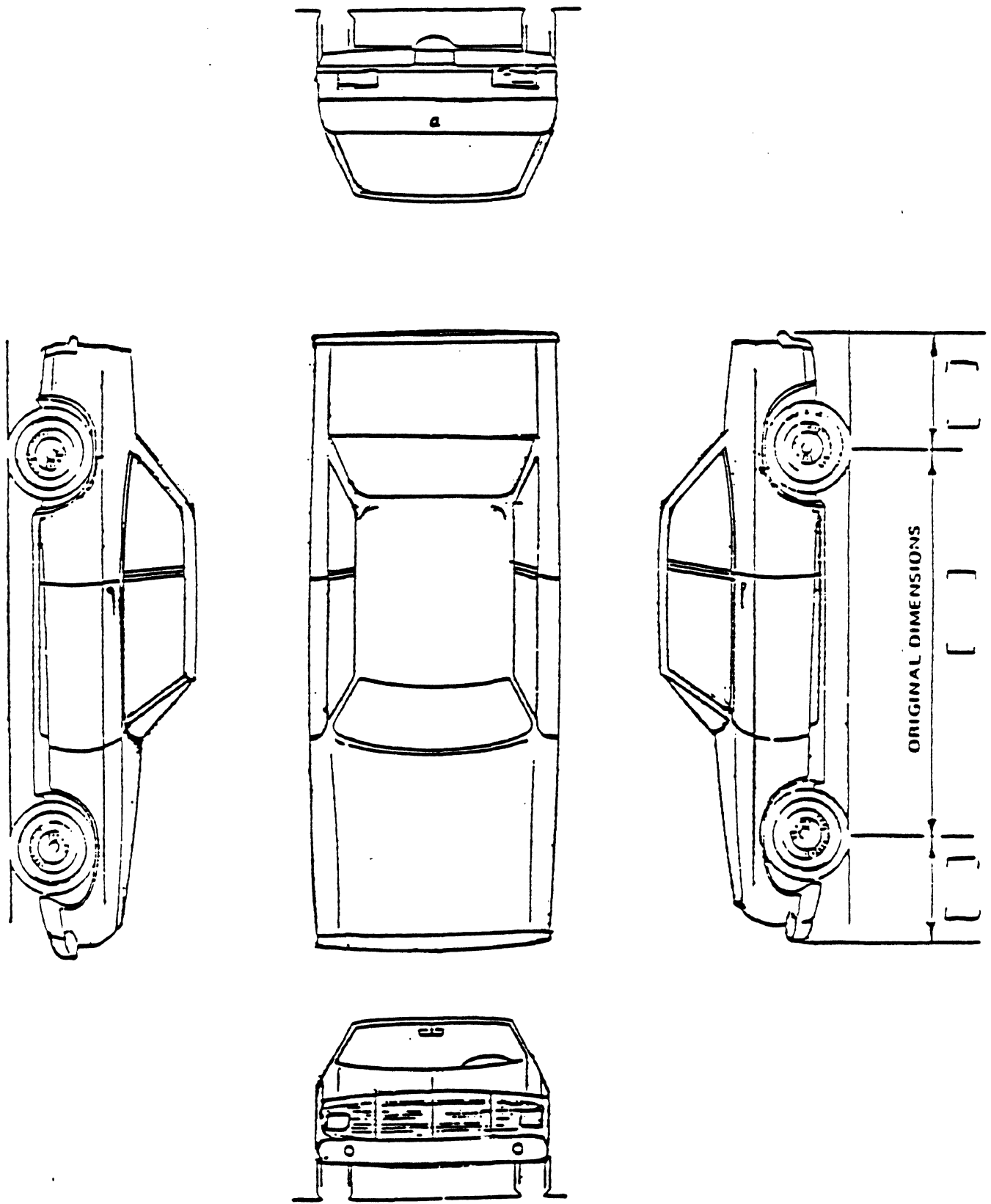

Optional Damage Pictorial Diagram:
Two-Door Notchback Coupe

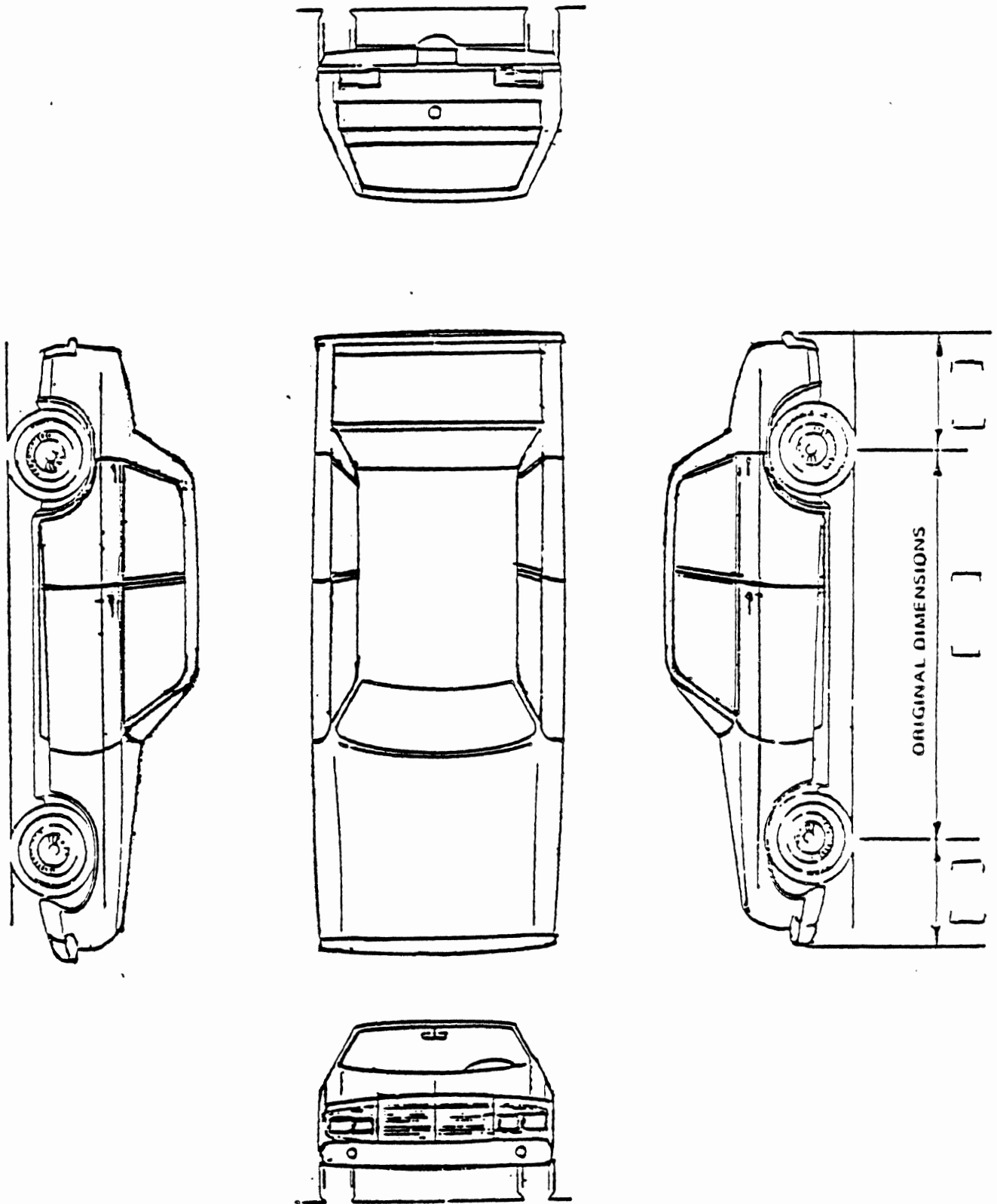

Optional Damage Pictorial Diagram:
Four-Door Notchback Sedan

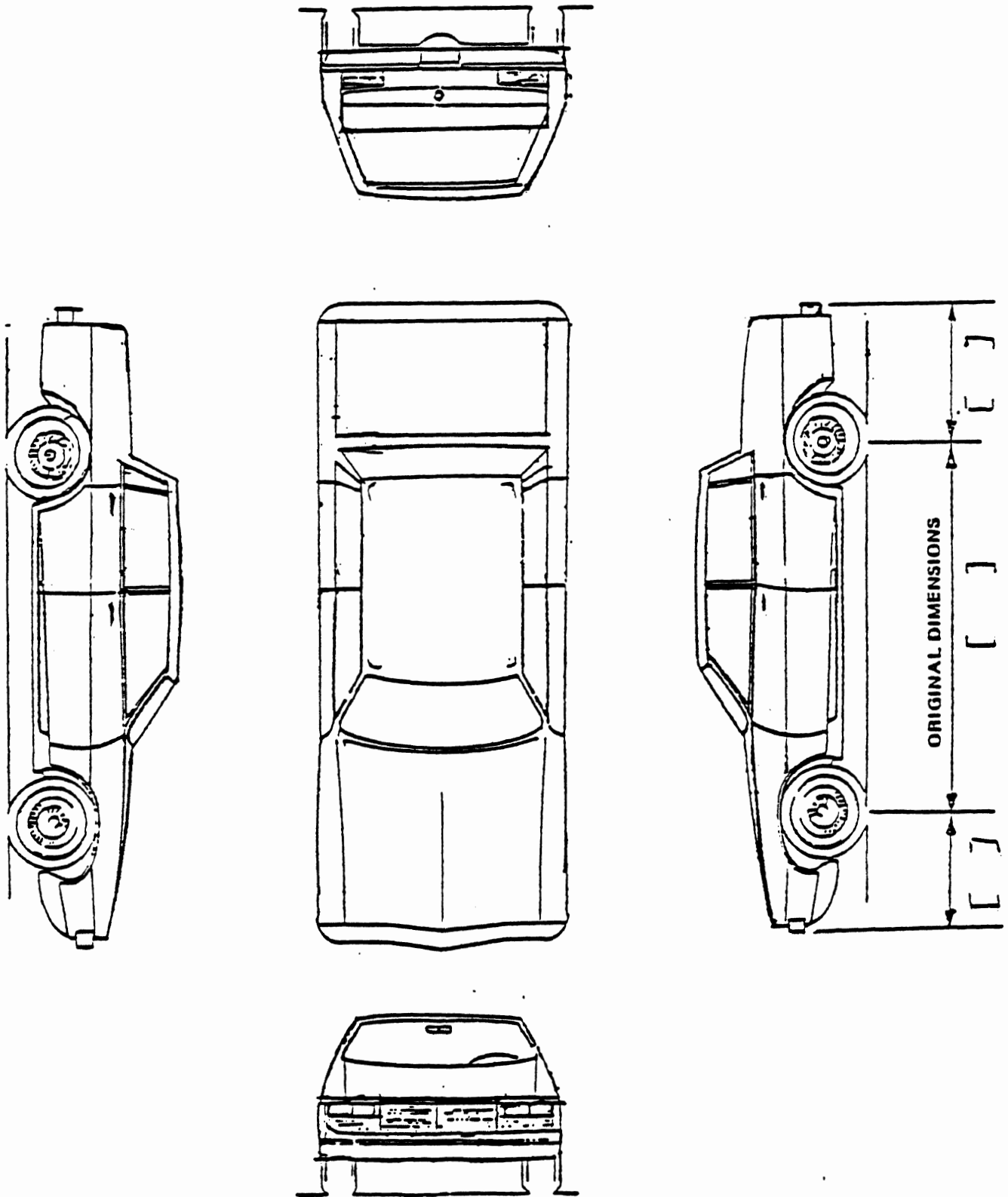

Optional Damage Pictorial Diagram:
Four-Door Sedan with Rear or "Opera" Windows

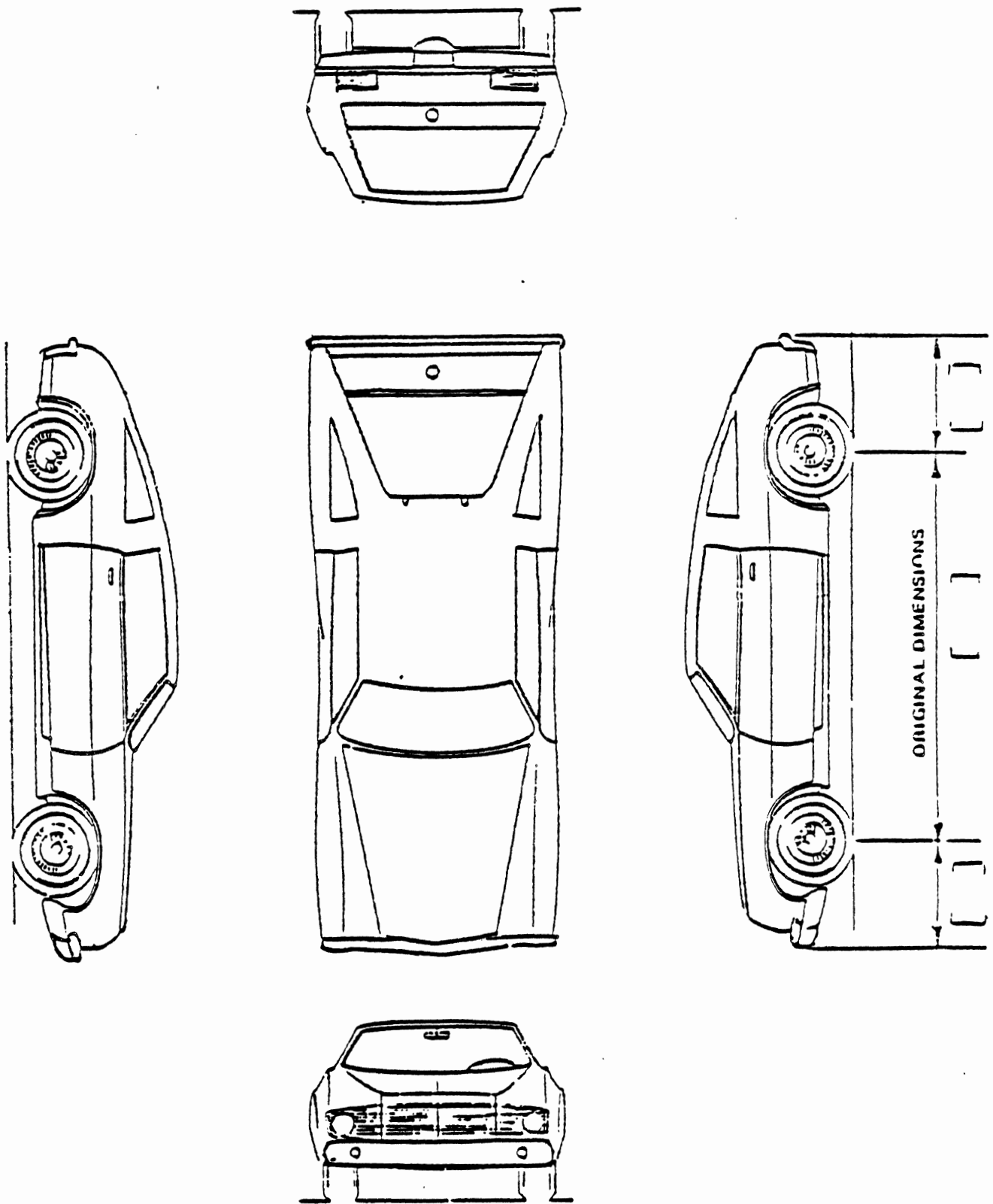

Optional Damage Pictorial Diagram:
Two-Door Fastback

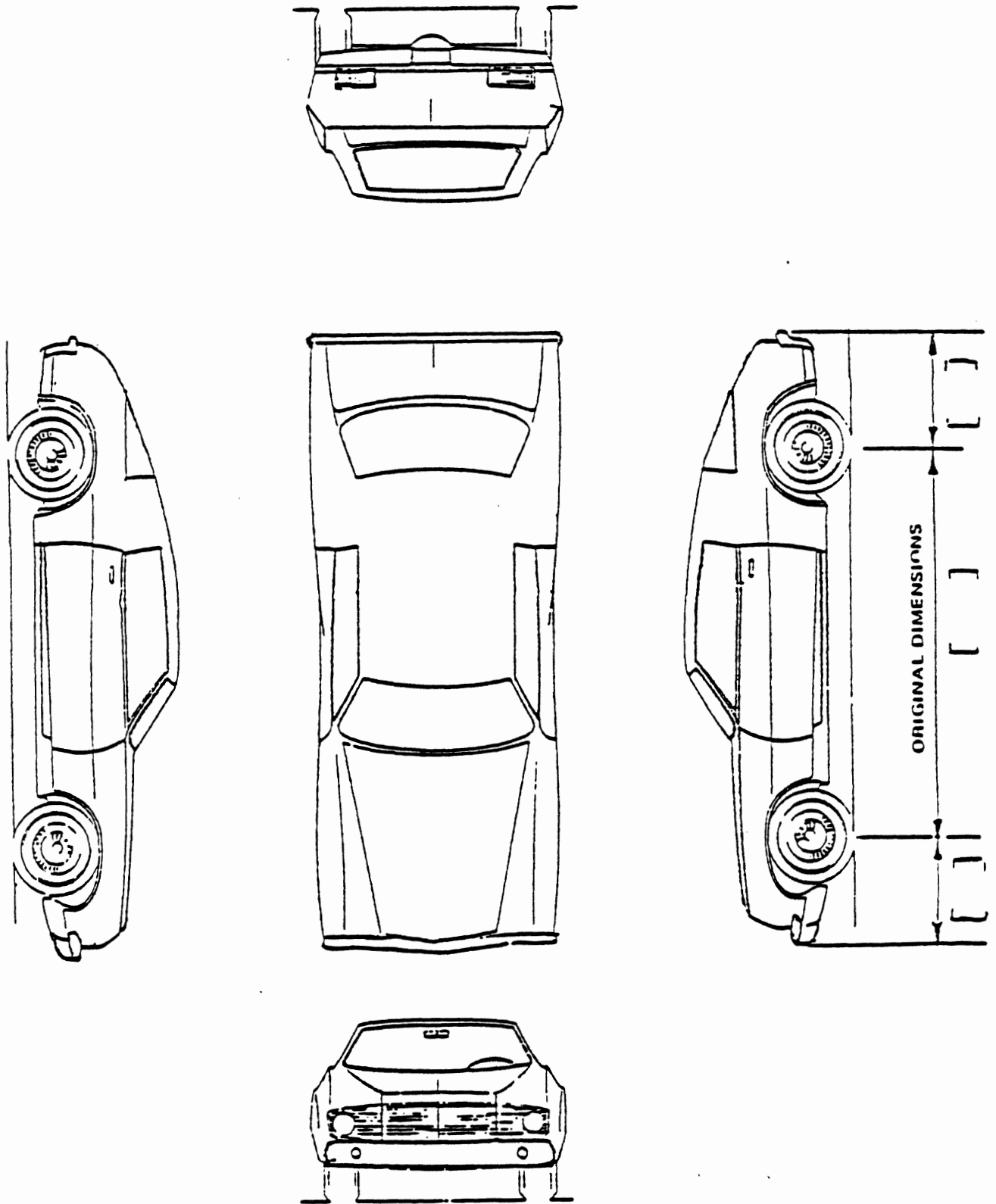

Optional Damage Pictorial Diagram:

Two-Door Fastback with Wrap-Around Rear Window

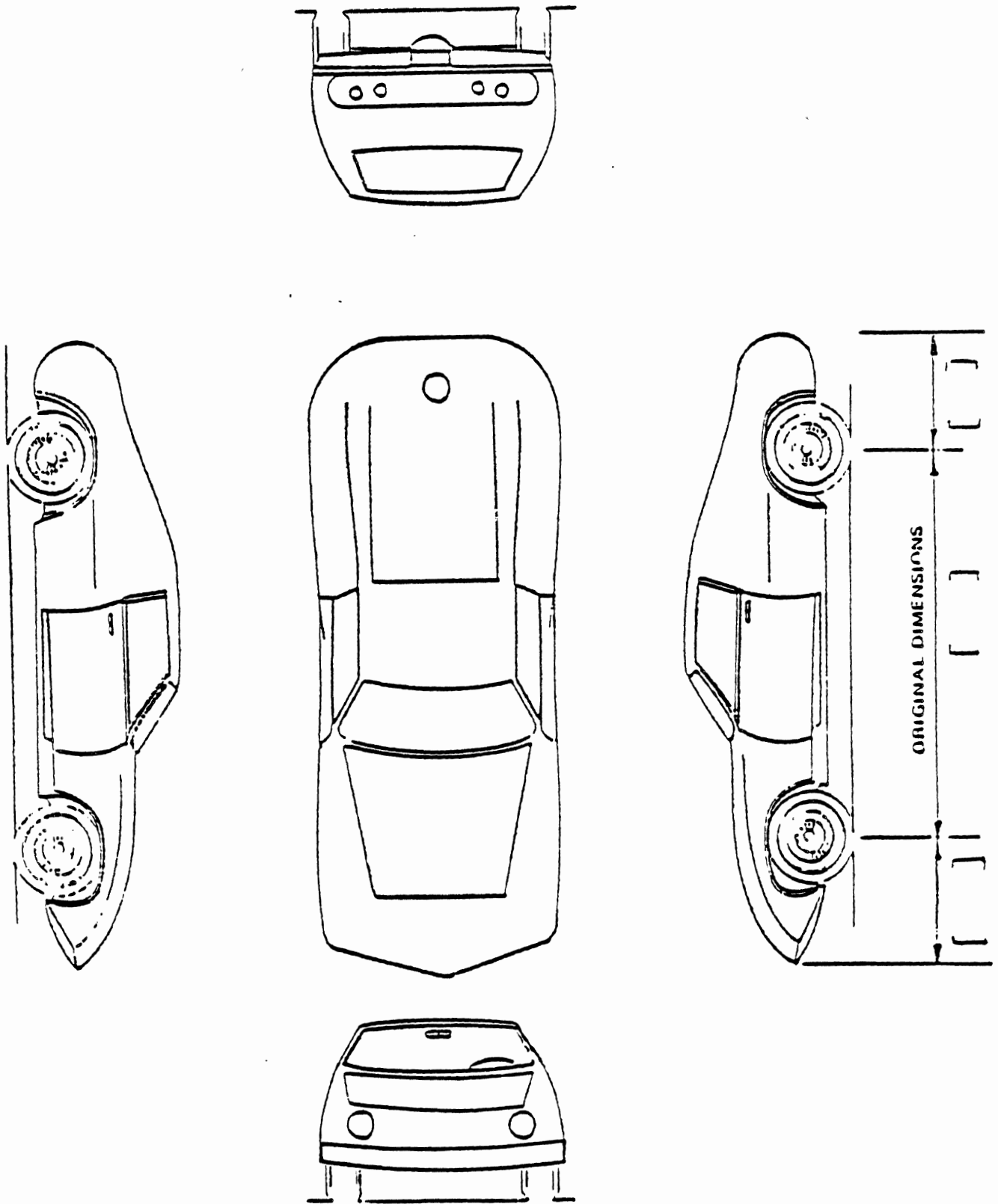

Optional Damage Pictorial Diagram:
Two-Door Sport Coupe

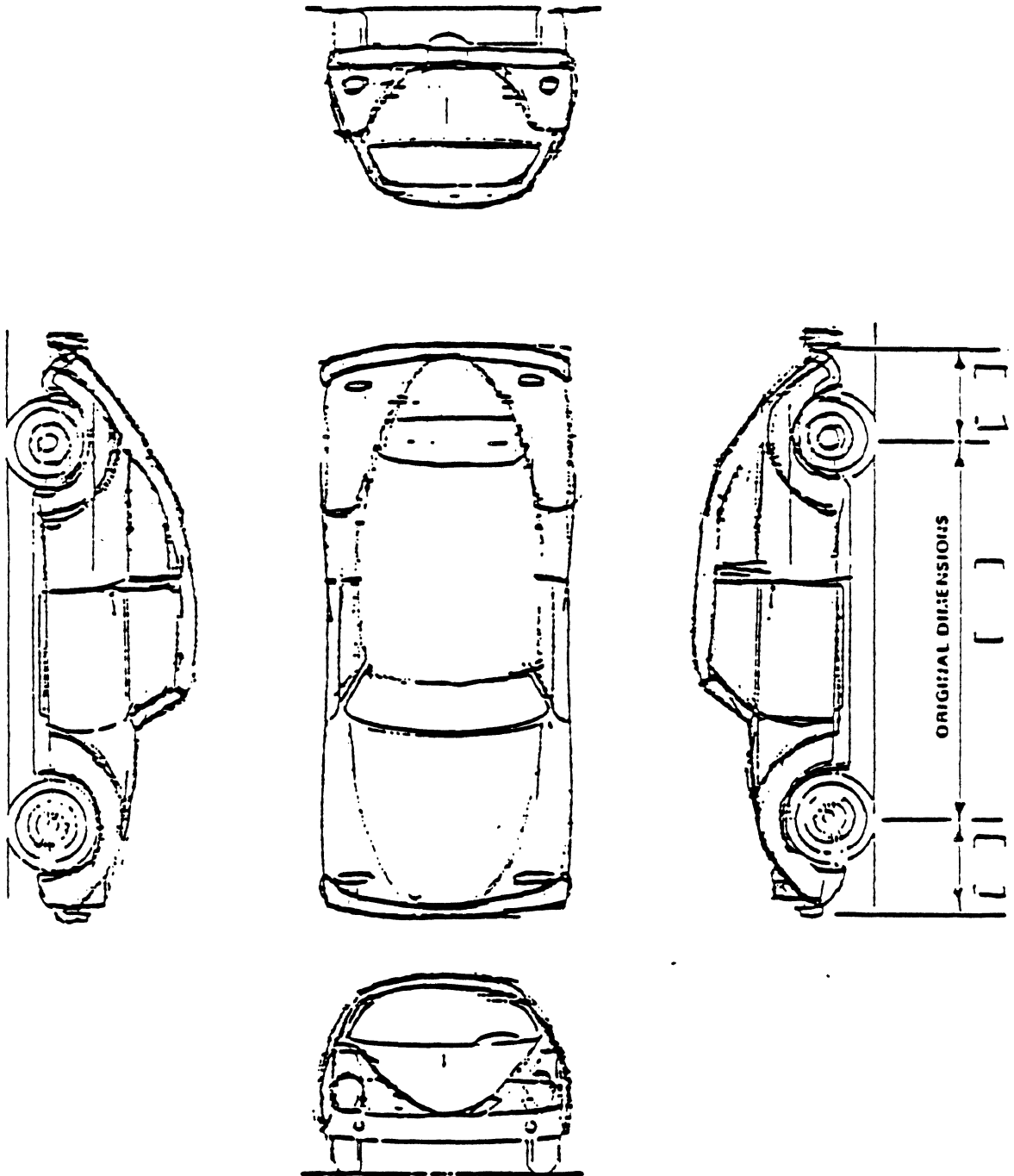

Optional Damage Pictorial Diagram:
Two-Door VW "Beetle"

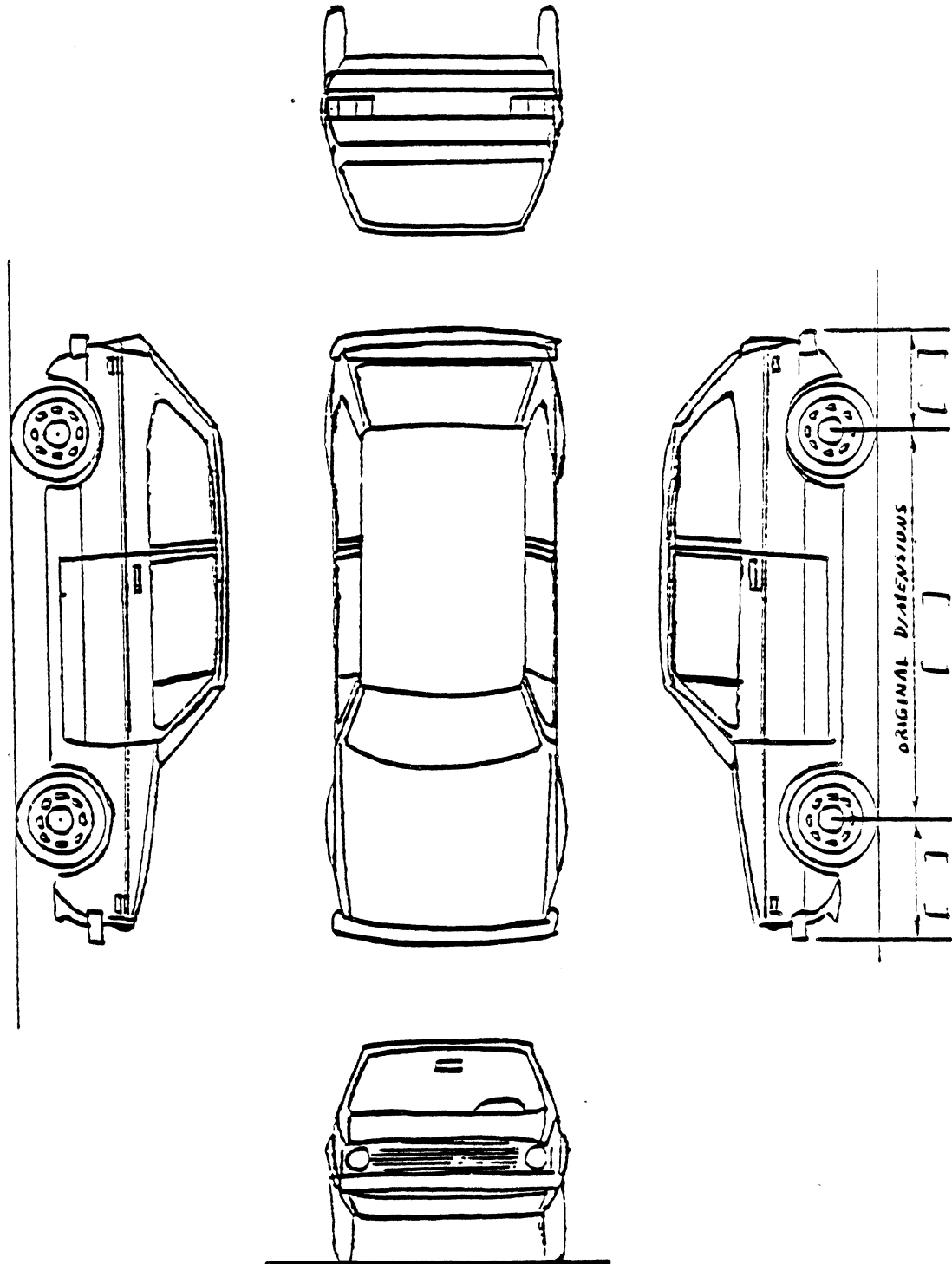

Optional Damage Pictorial Diagram:
Two-Door Hatchback Coupe (Subcompact)

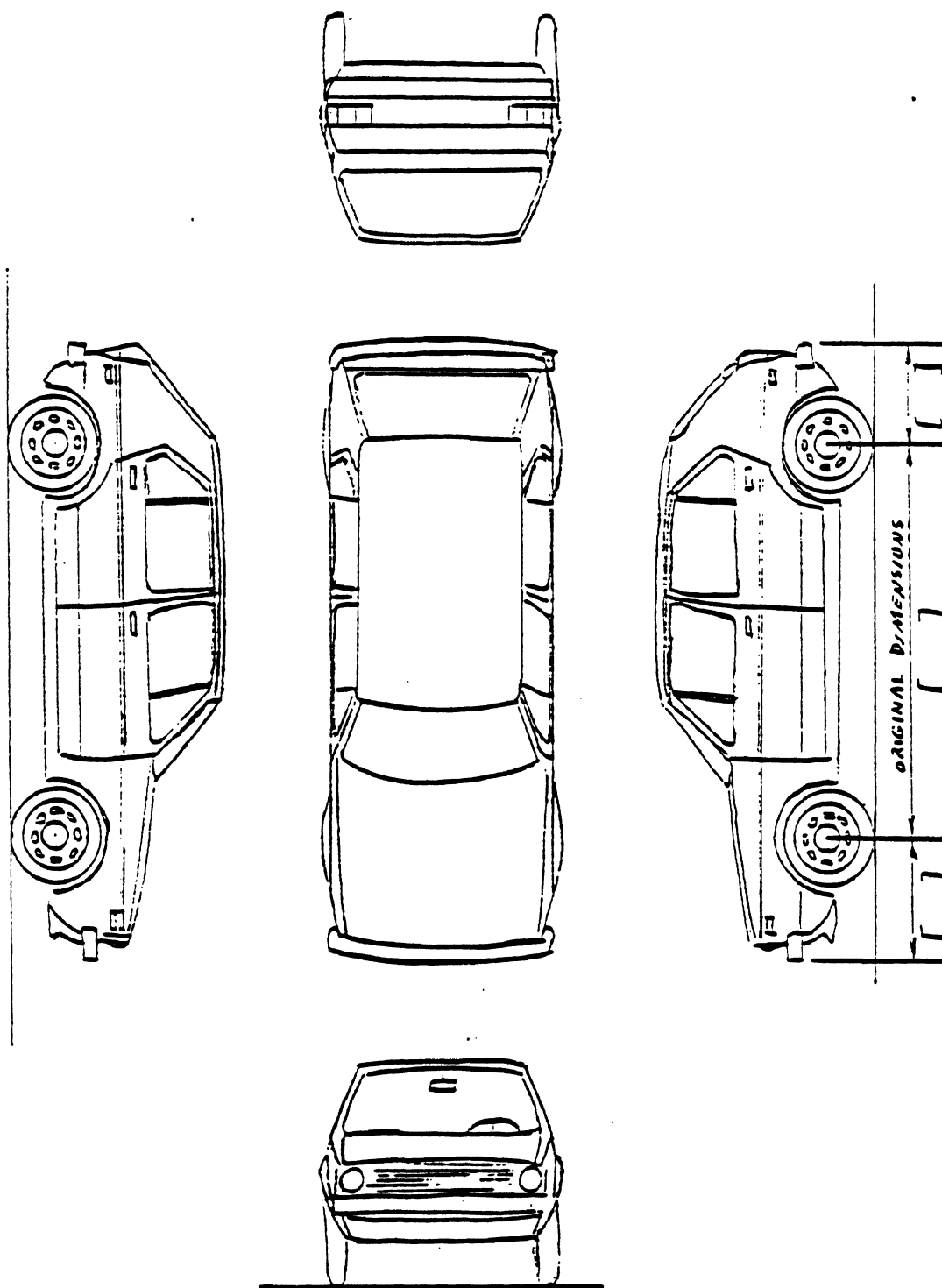

Optional Damage Pictorial Diagram:
Four-Door Hatchback Sedan (Subcompact)

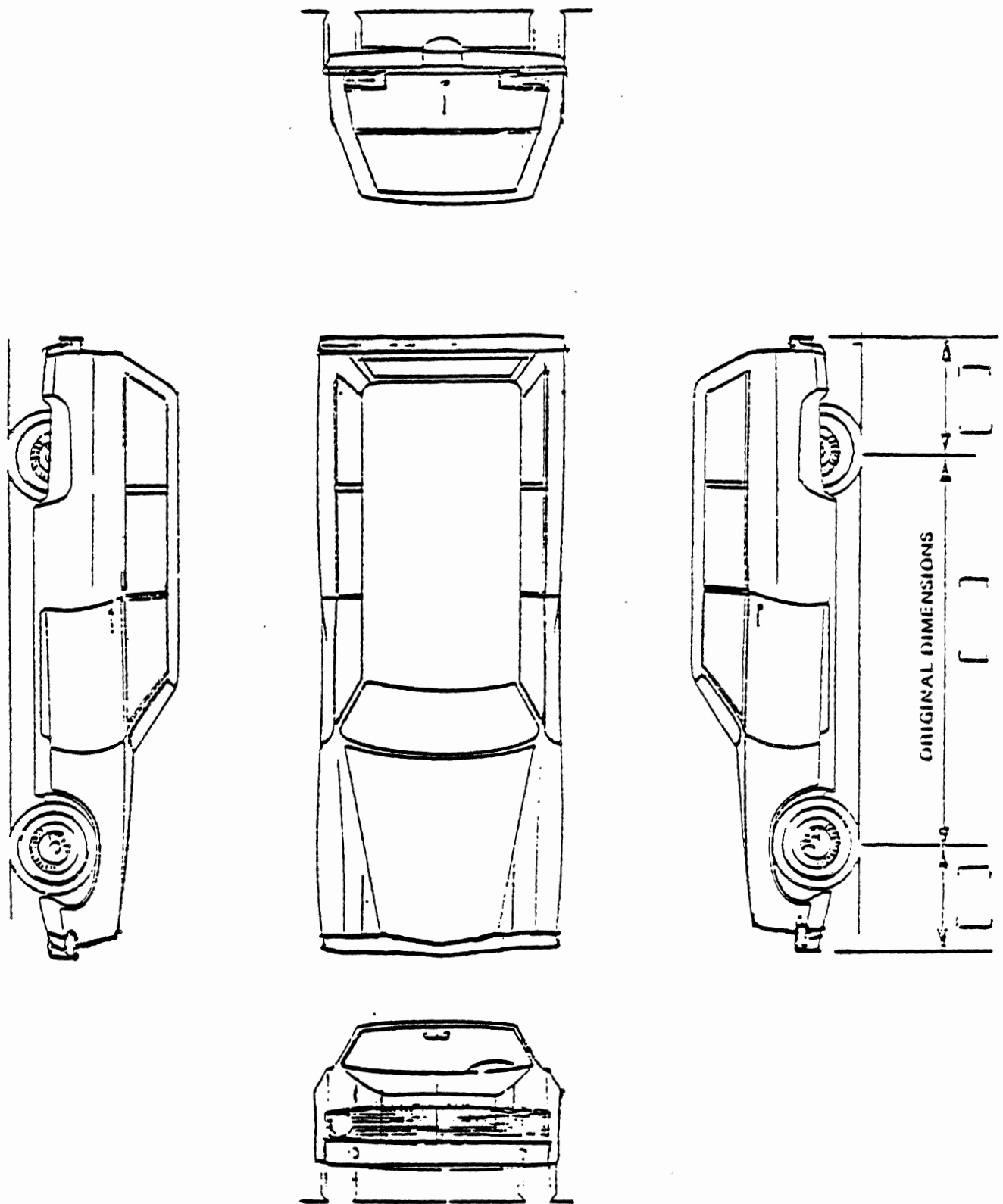

Optional Damage Pictorial Diagram:
Two-Door Station Wagon

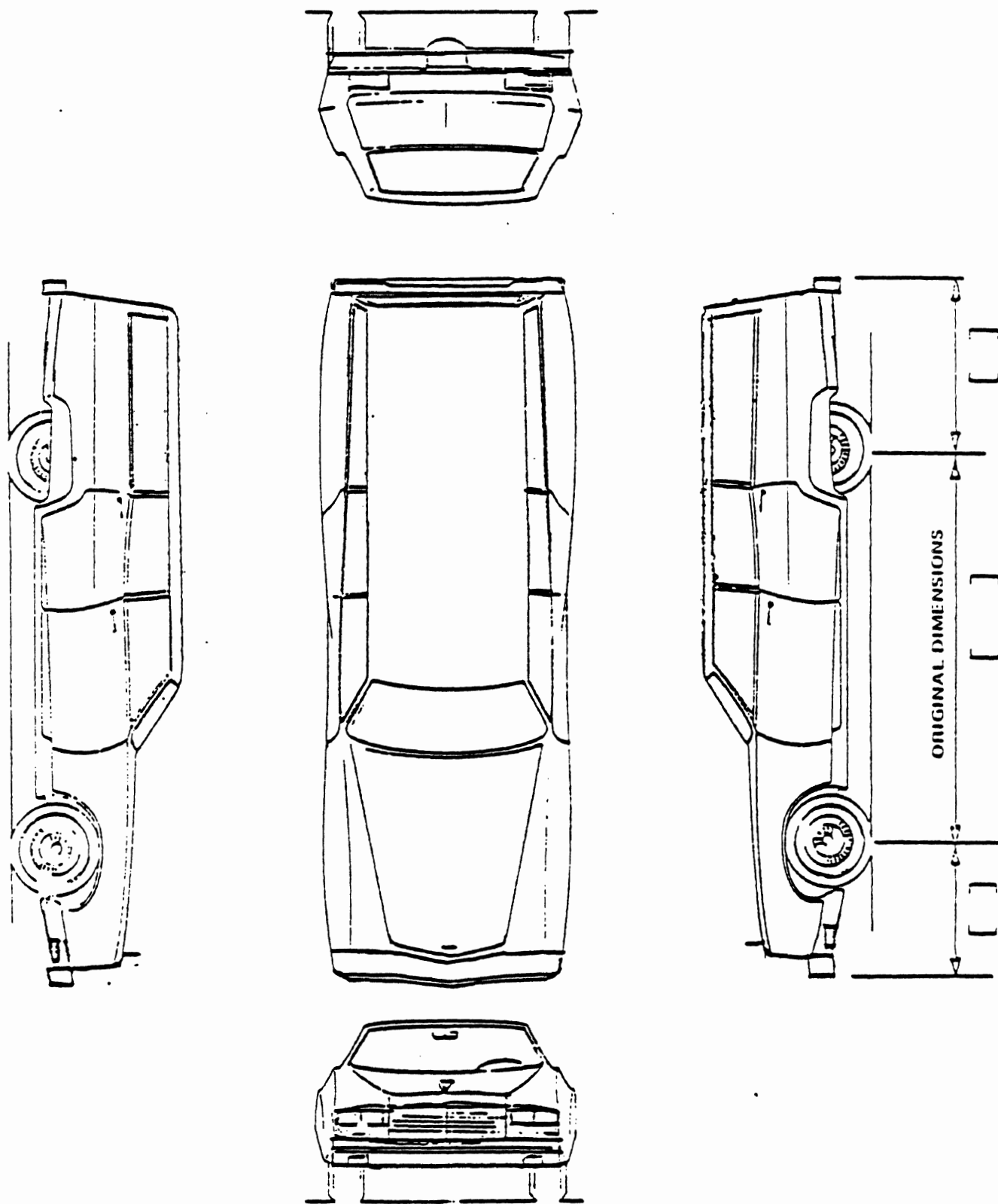

Optional Damage Pictorial Diagram:
Four-Door Station Wagon

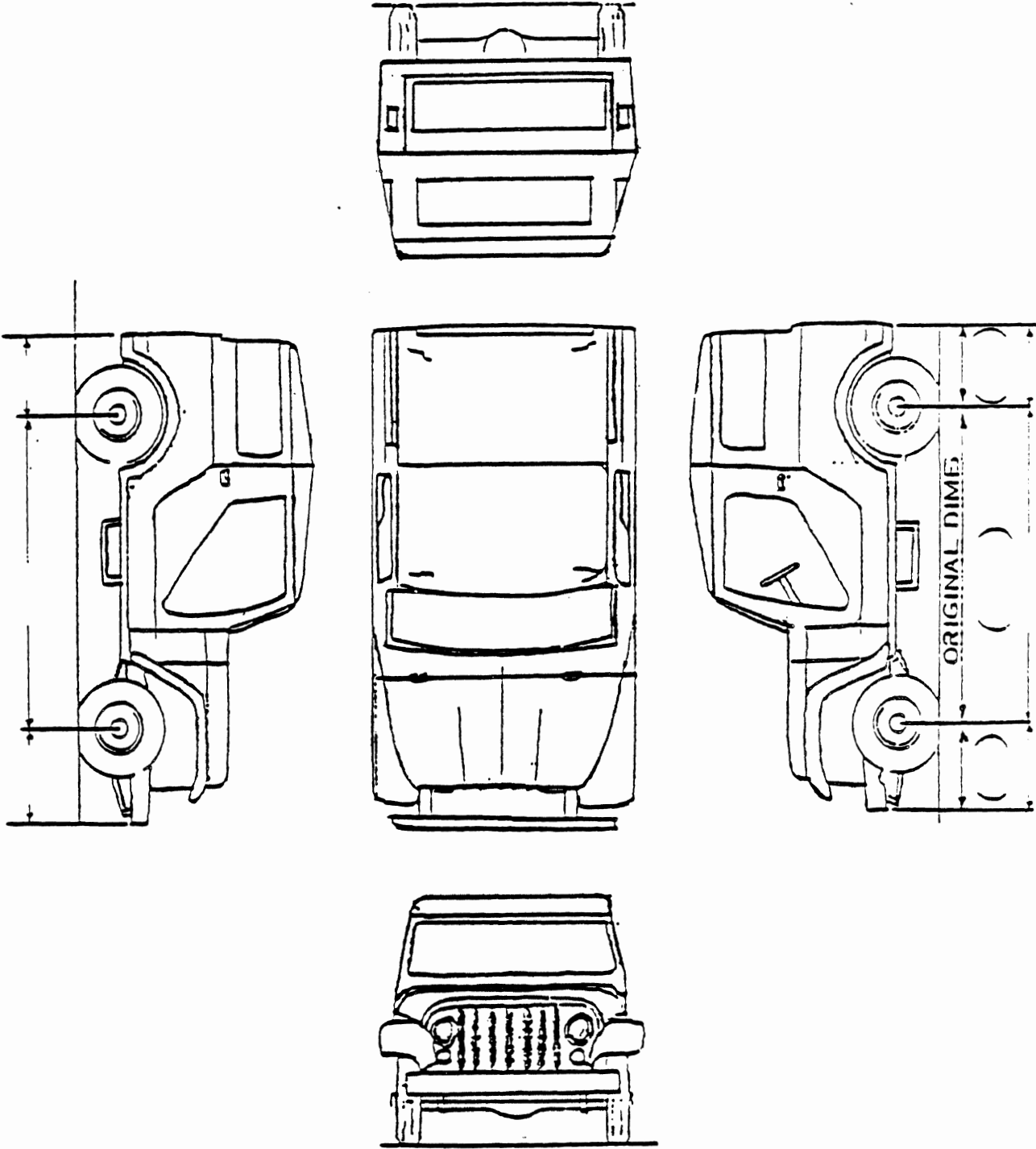

Optional Damage Pictorial Diagram:
 Two-Door (Short-Wheelbase) Utility Vehicle
 ("Jeep"-Type Design)

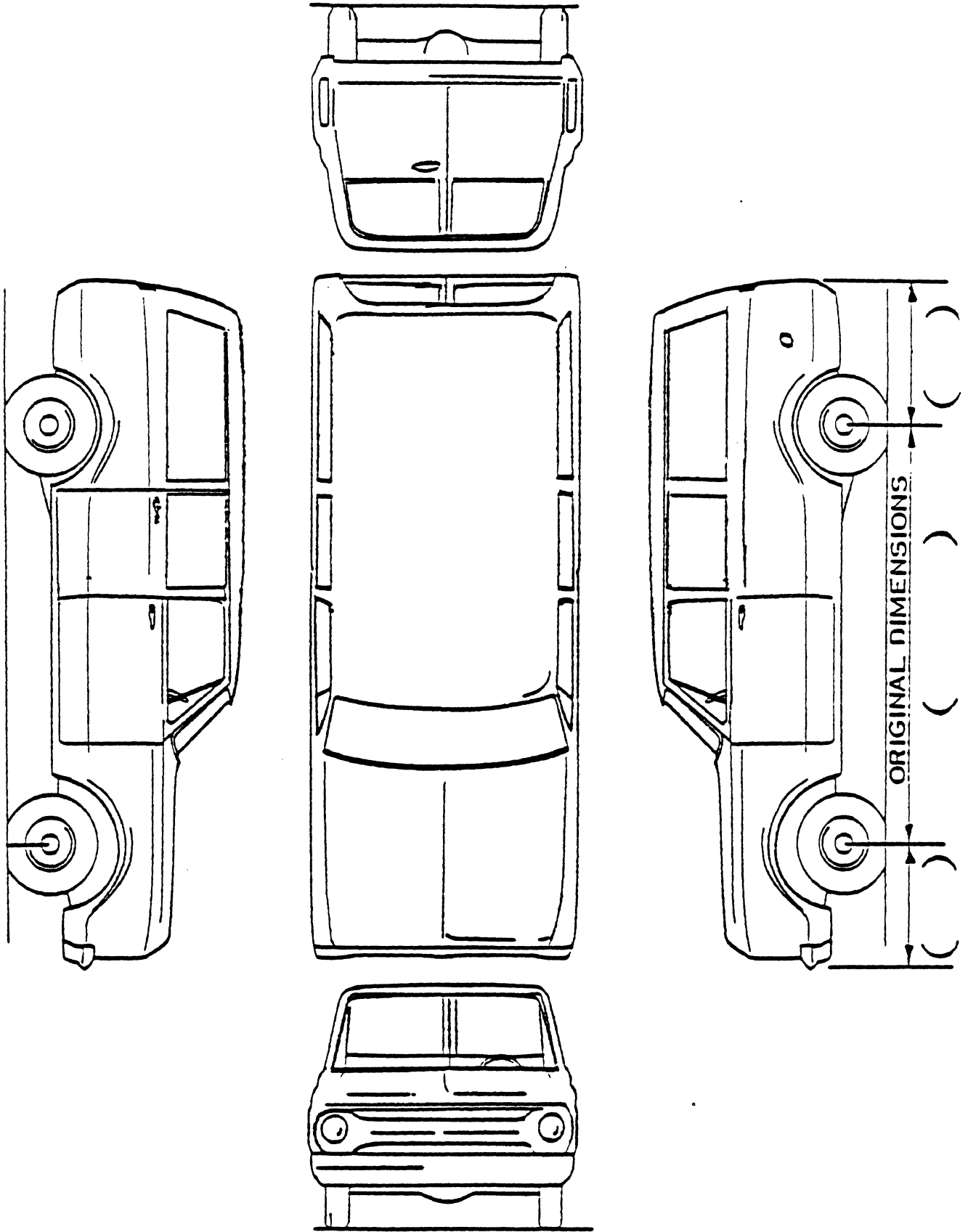

Optional Damage Pictorial Diagram:
Three-Door (Long-Wheelbase) Utility Vehicle

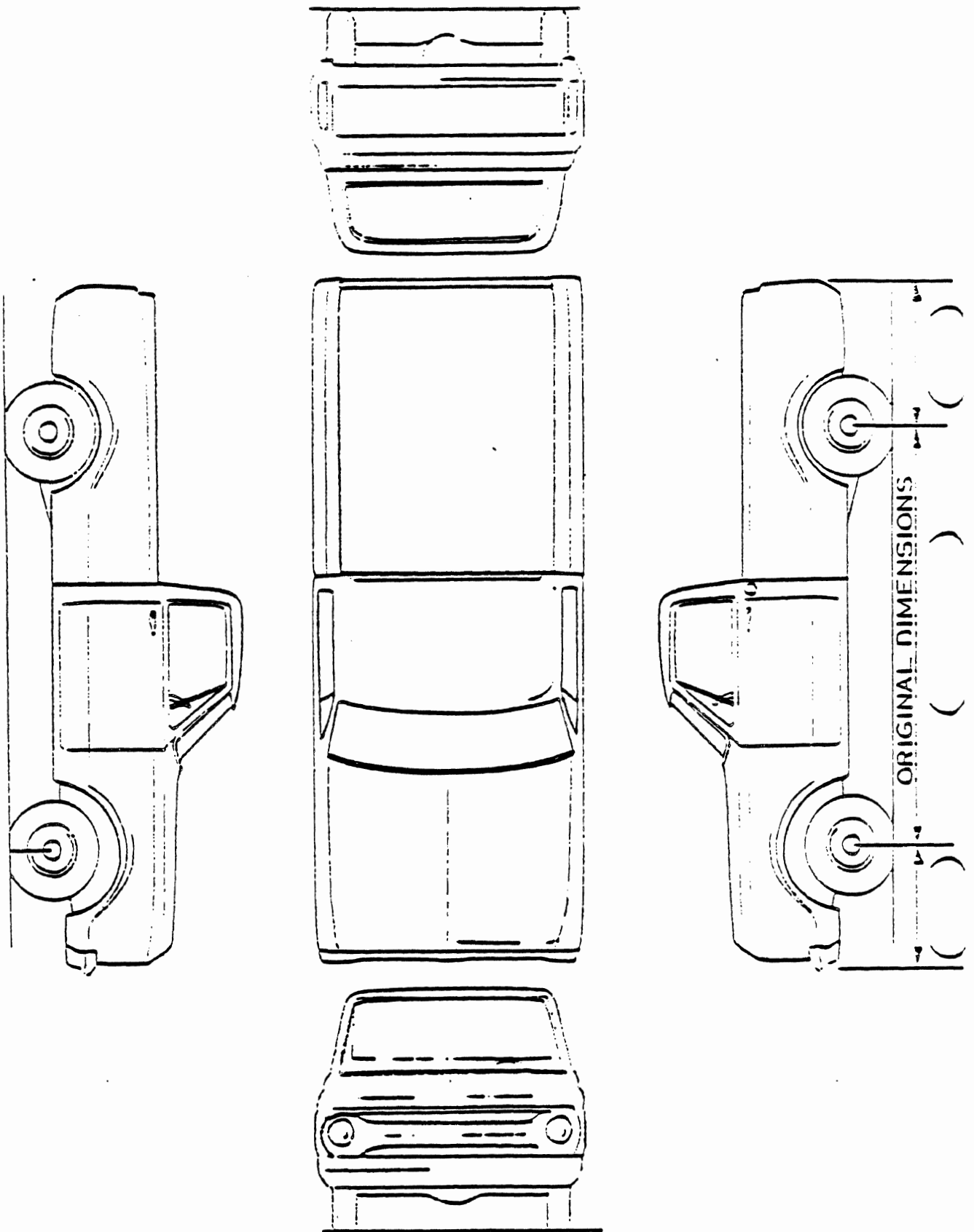

Optional Damage Pictorial Diagram:
Two-Door Conventional Pick-Up Truck (Alone)

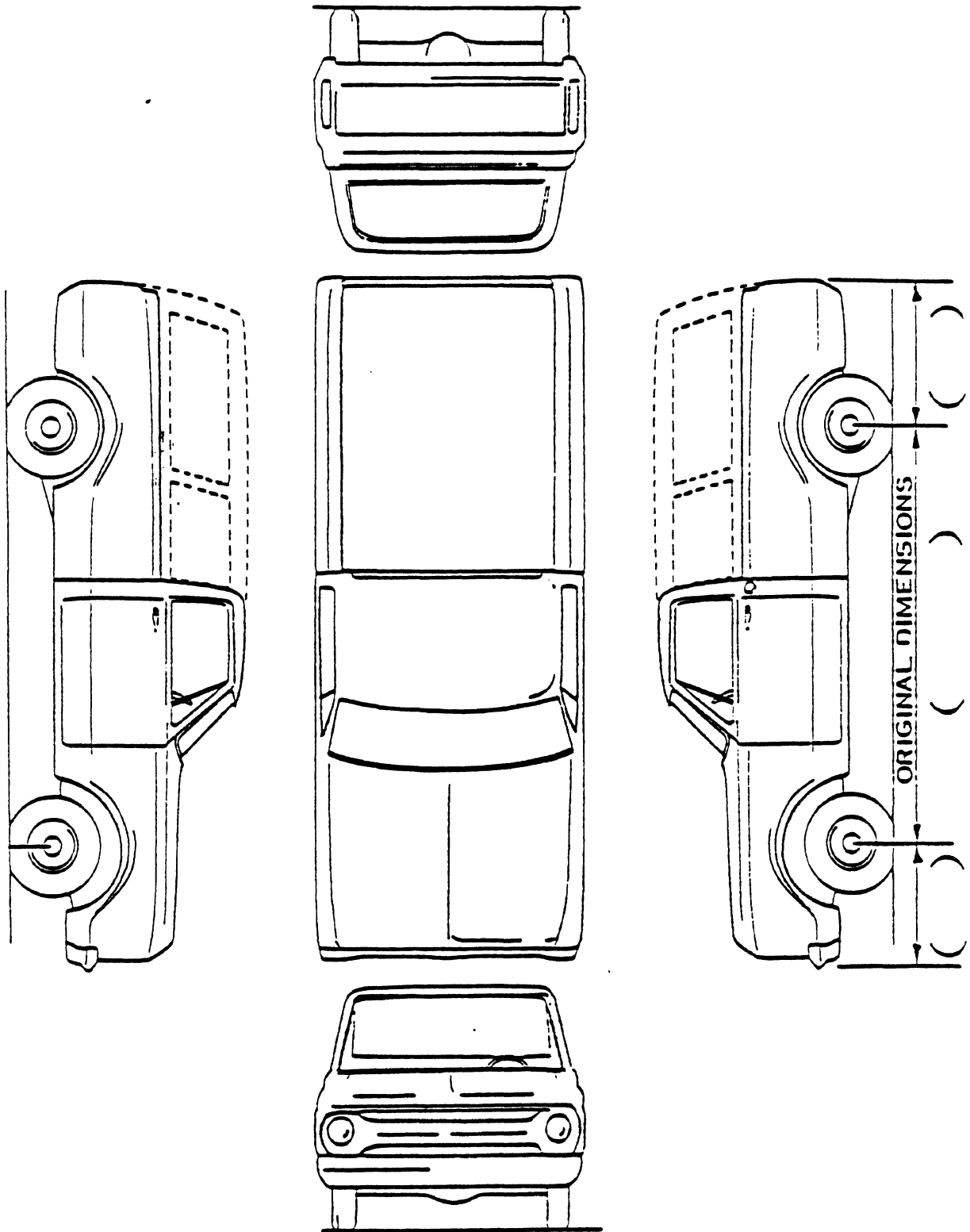

Optional Damage Pictorial Diagram:
Two-Door Pick-Up Truck with Canopy or Shell

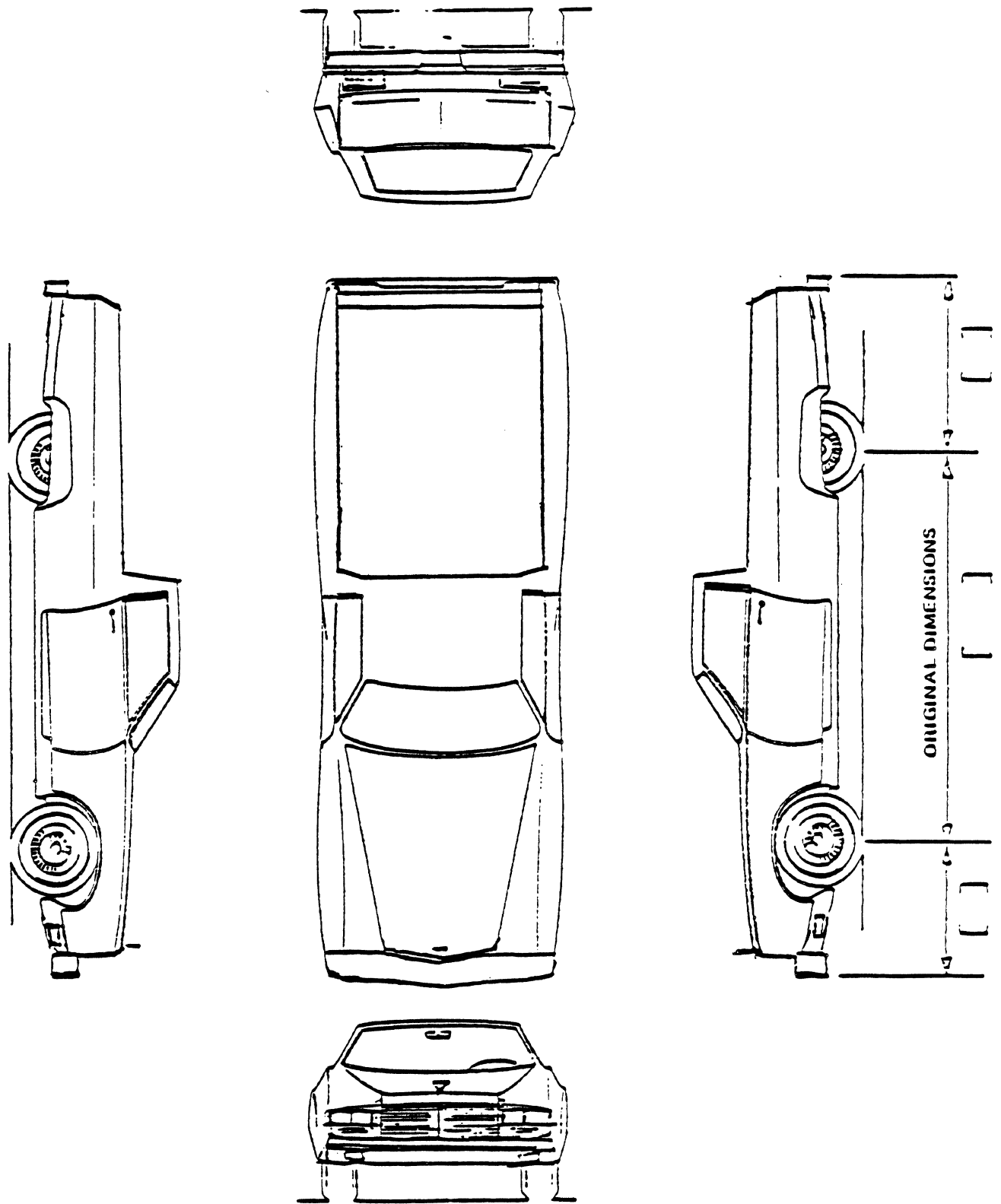

Optional Damage Pictorial Diagram:
Two-Door Pick-Up Car

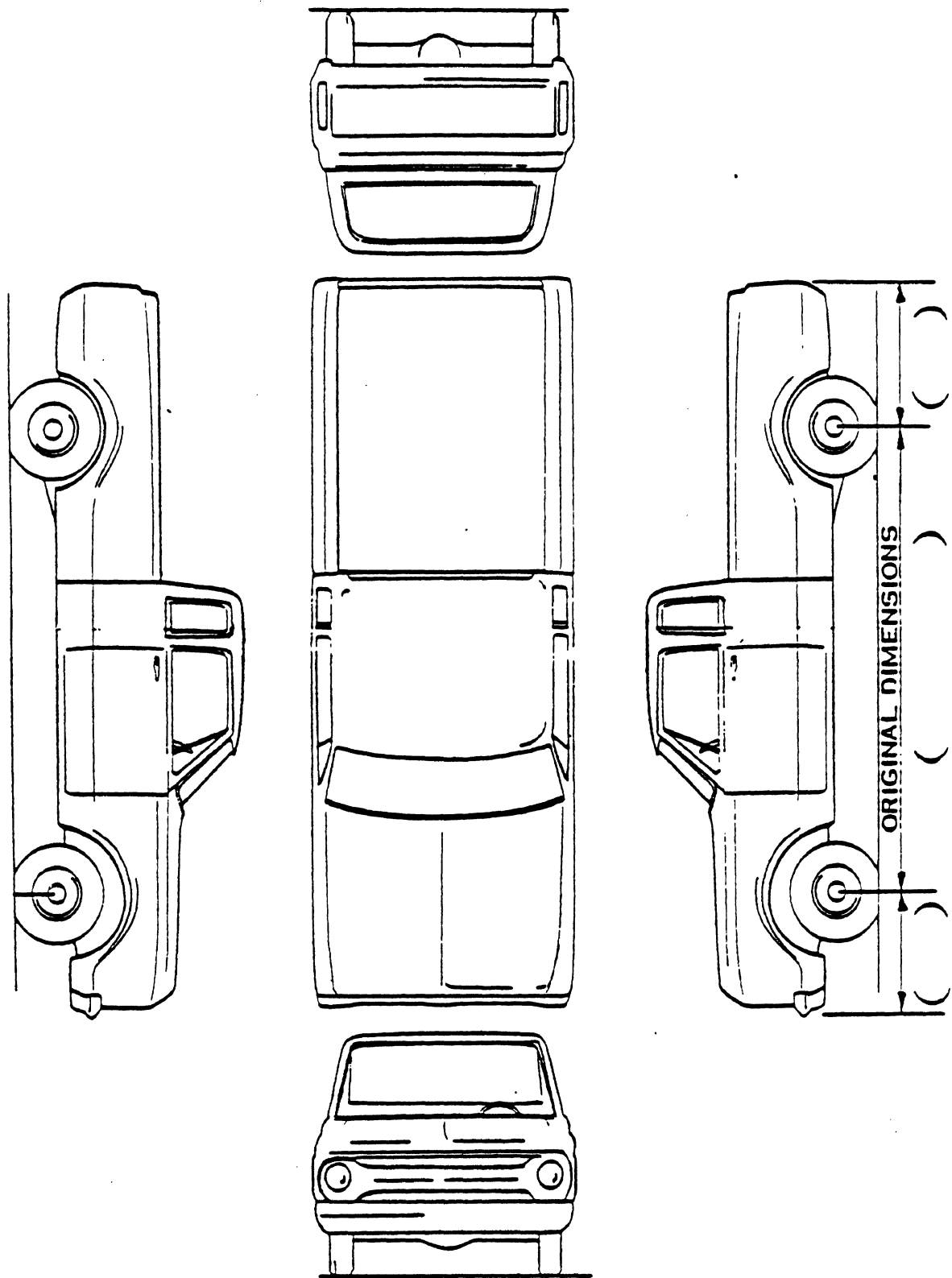

Optional Damage Pictorial Diagram:

Two-Door Pick-Up Truck with Extended Cab (small window)

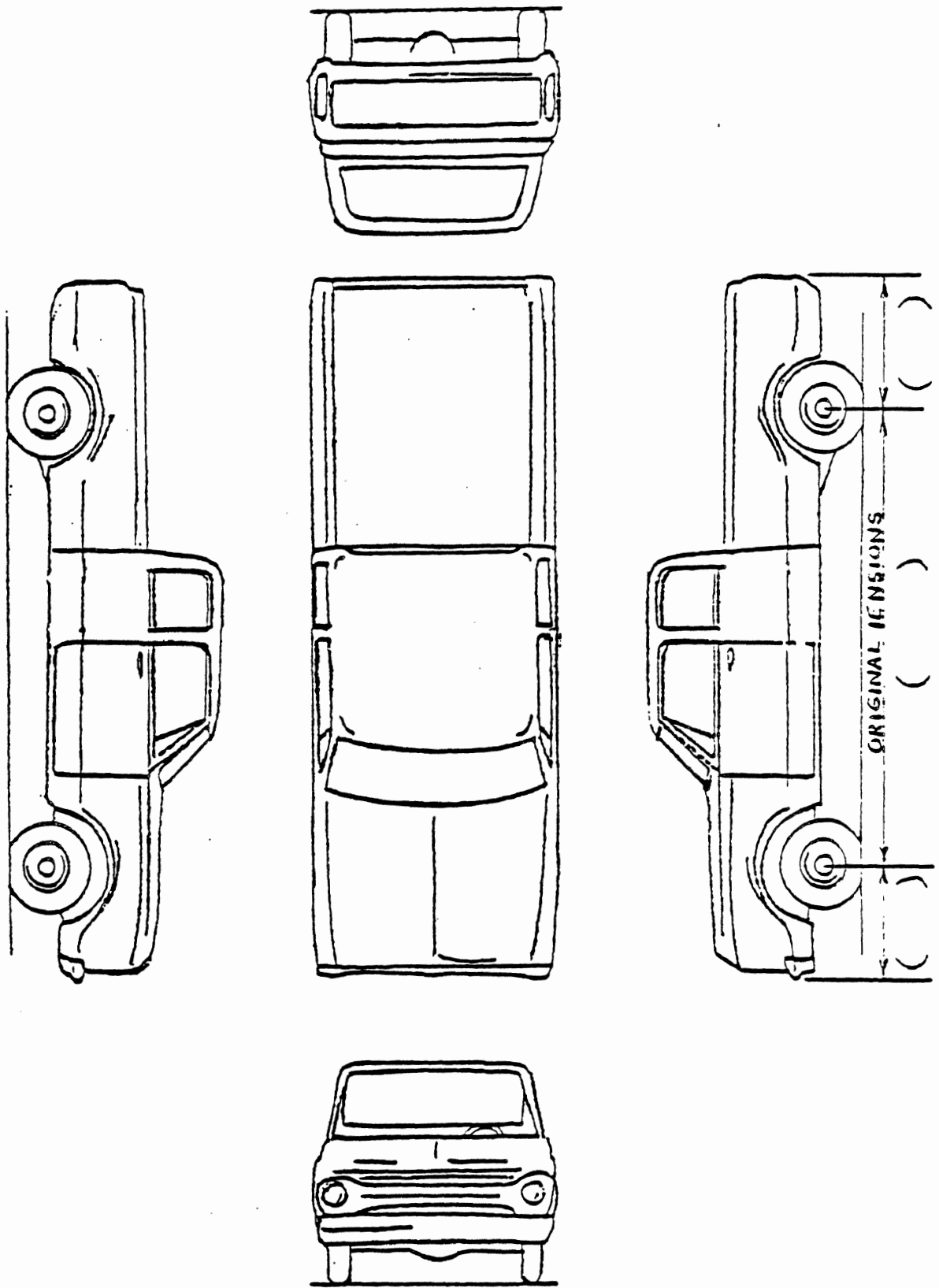

Optional Damage Pictorial Diagram:

Two-Door Pick-Up Truck with Extended Cab (large window)

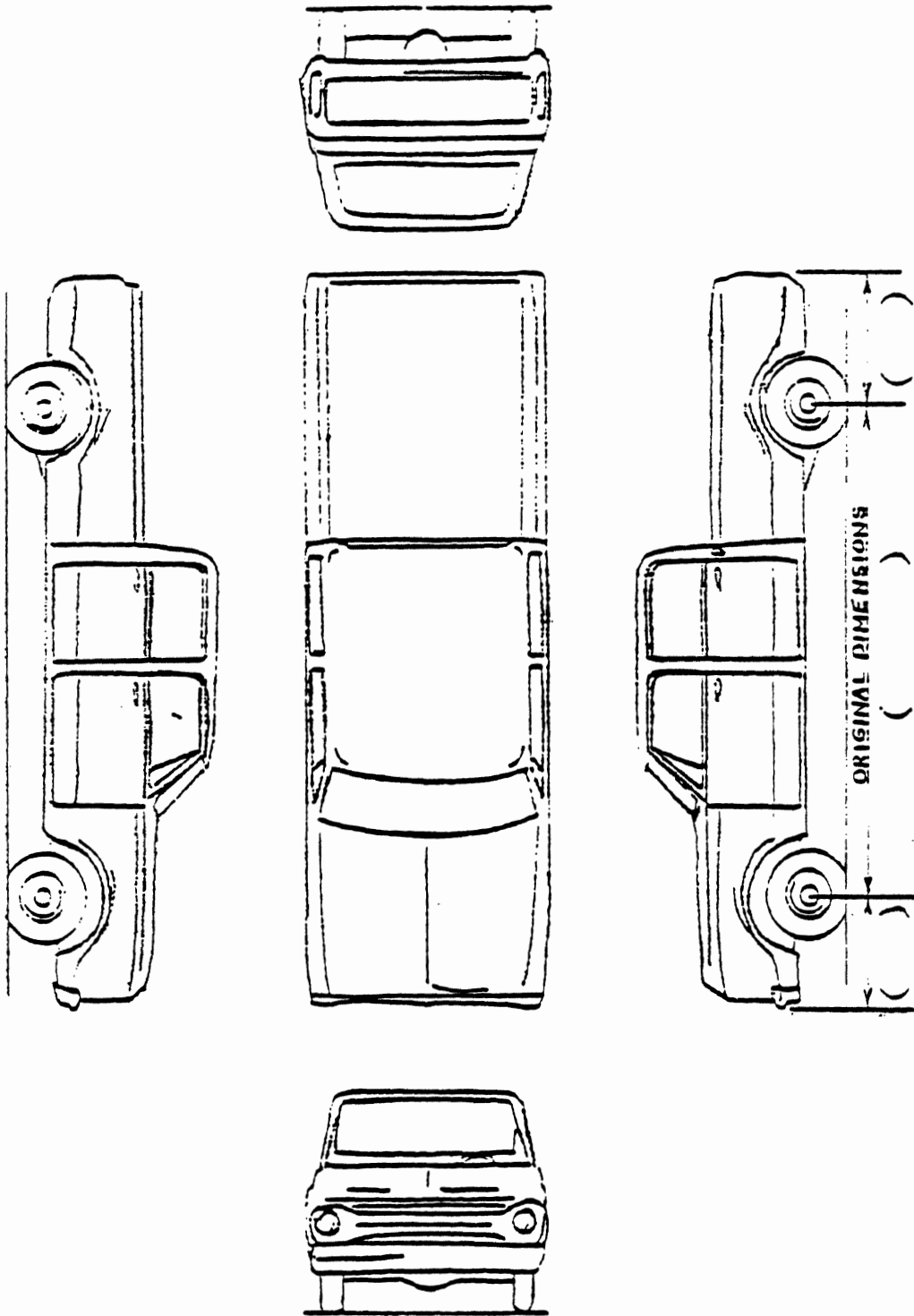

Optional Damage Pictorial Diagram:
Four-Door Pick-Up Truck ("Crew Cab")

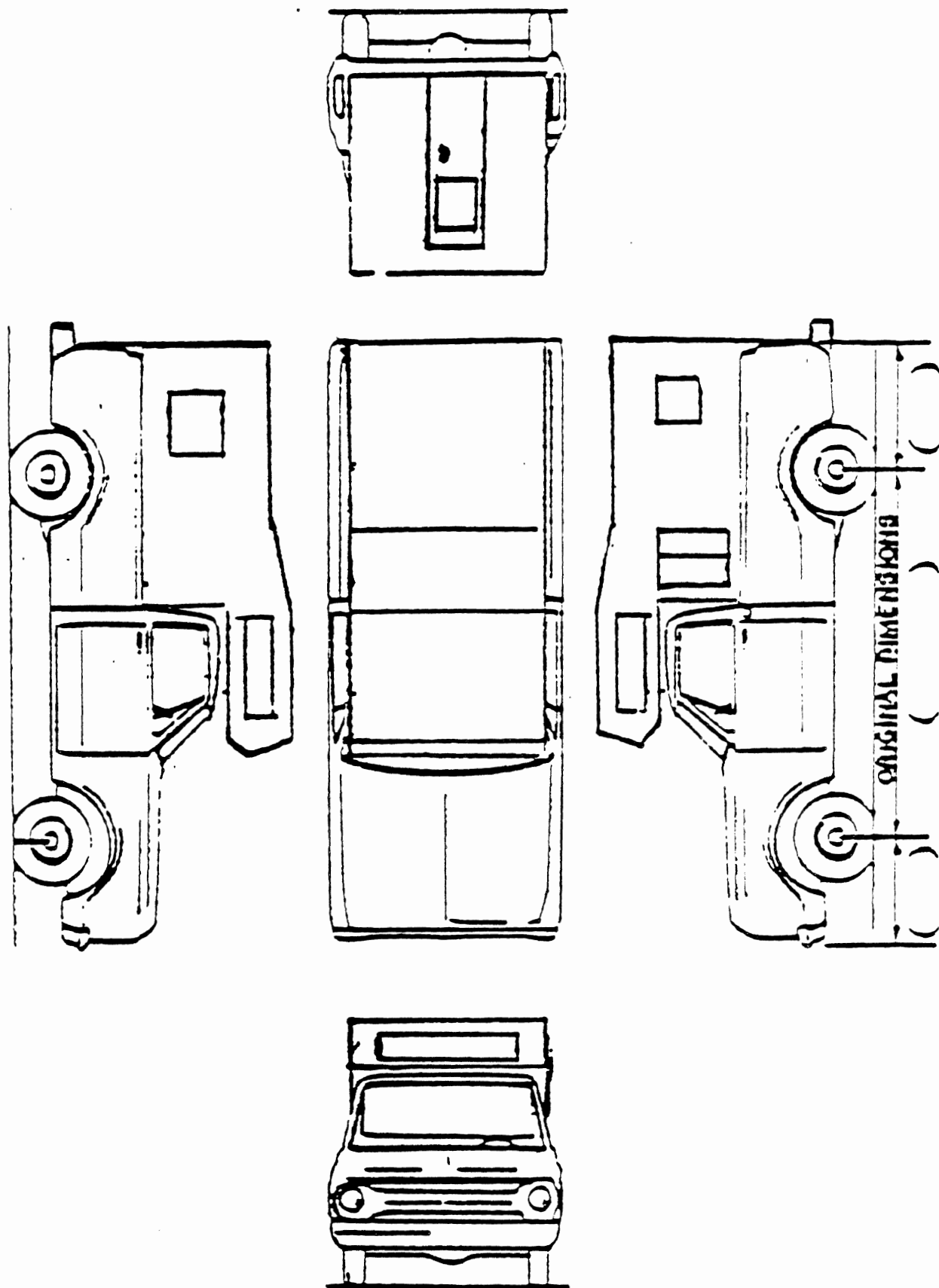

Optional Damage Pictorial Diagram:

Pick-Up Camper

Optional Damage Pictorial Diagram:
General "MPV/PU" Drawing

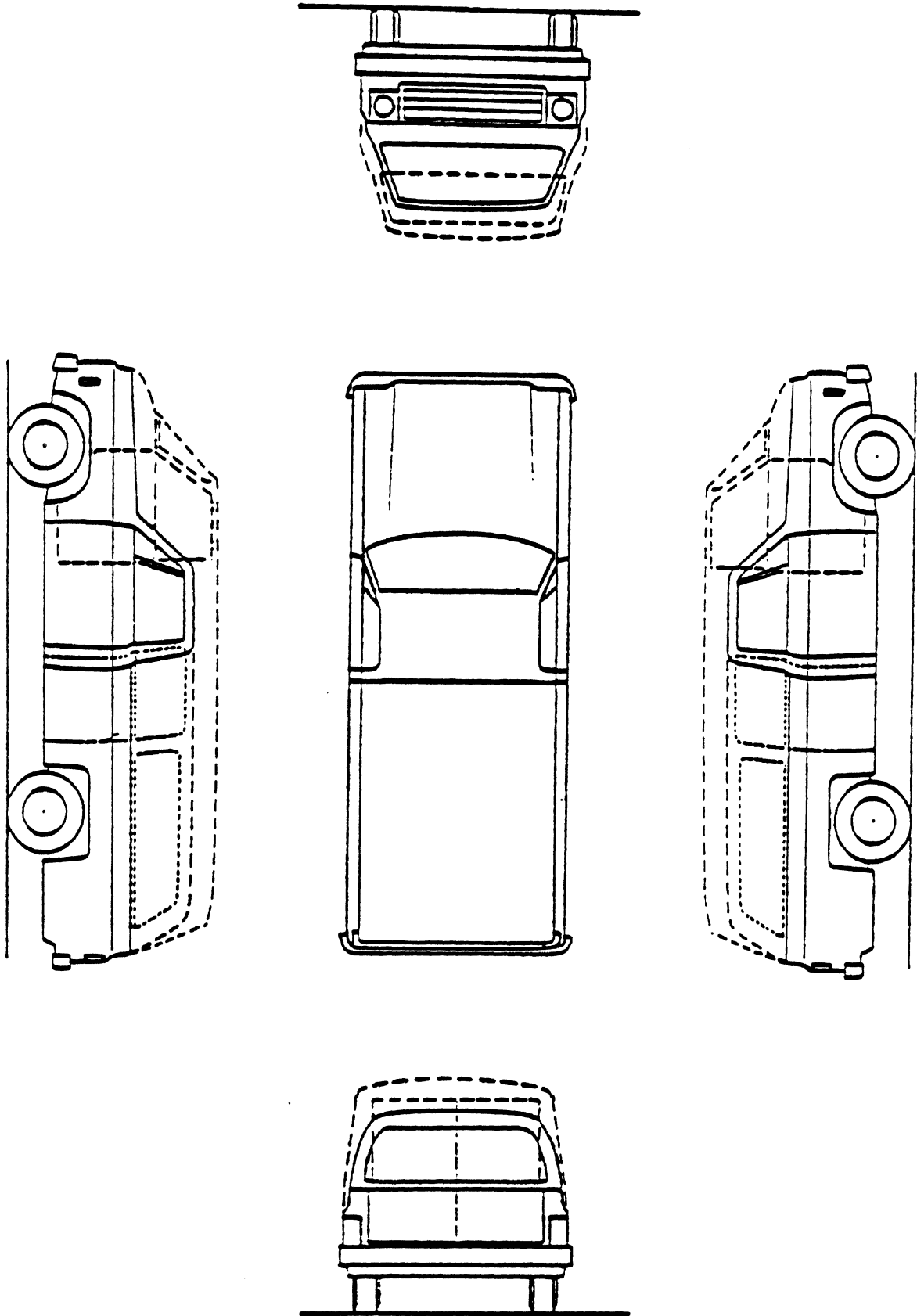

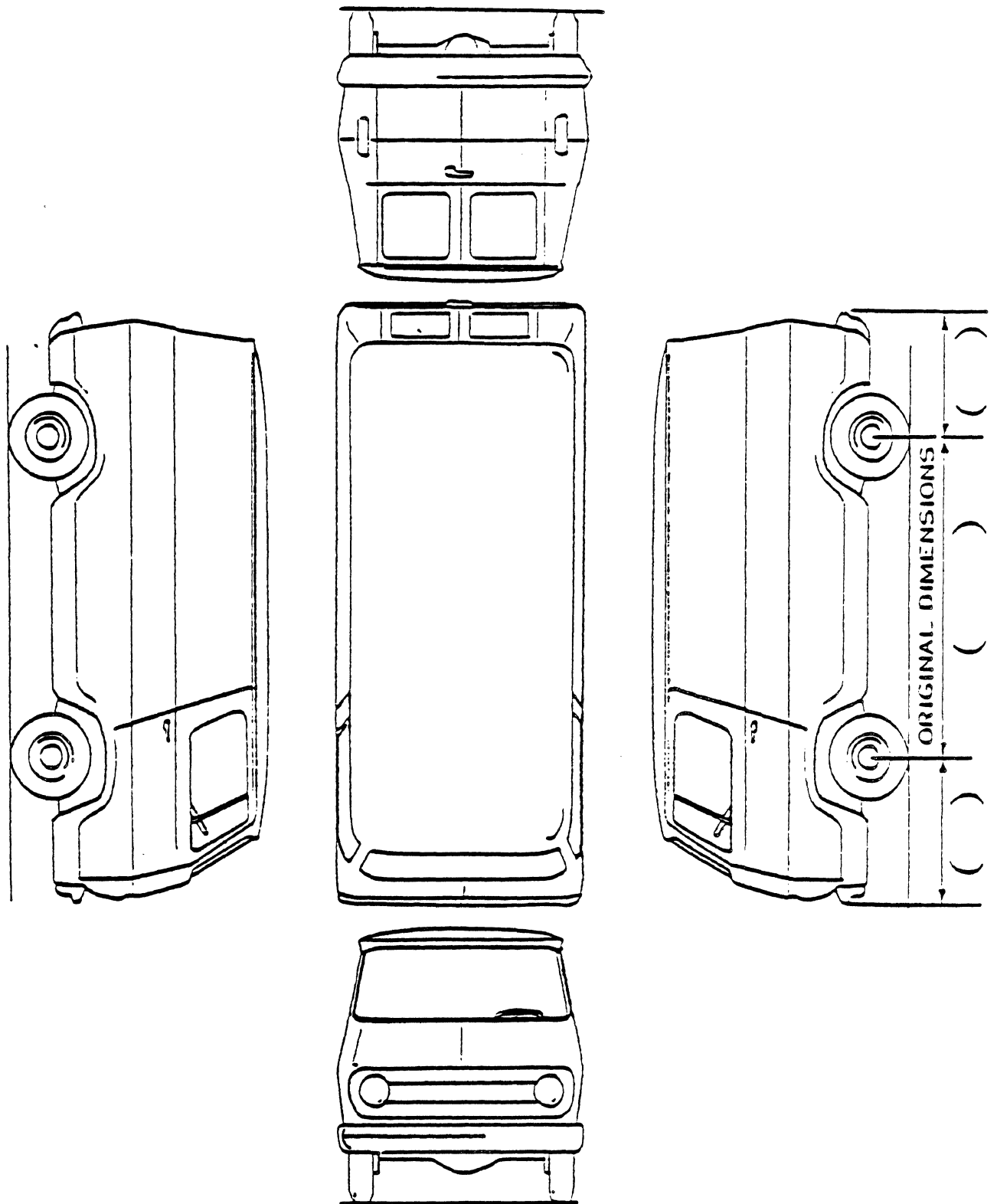

Optional Damage Pictorial Diagram:

Cargo Van

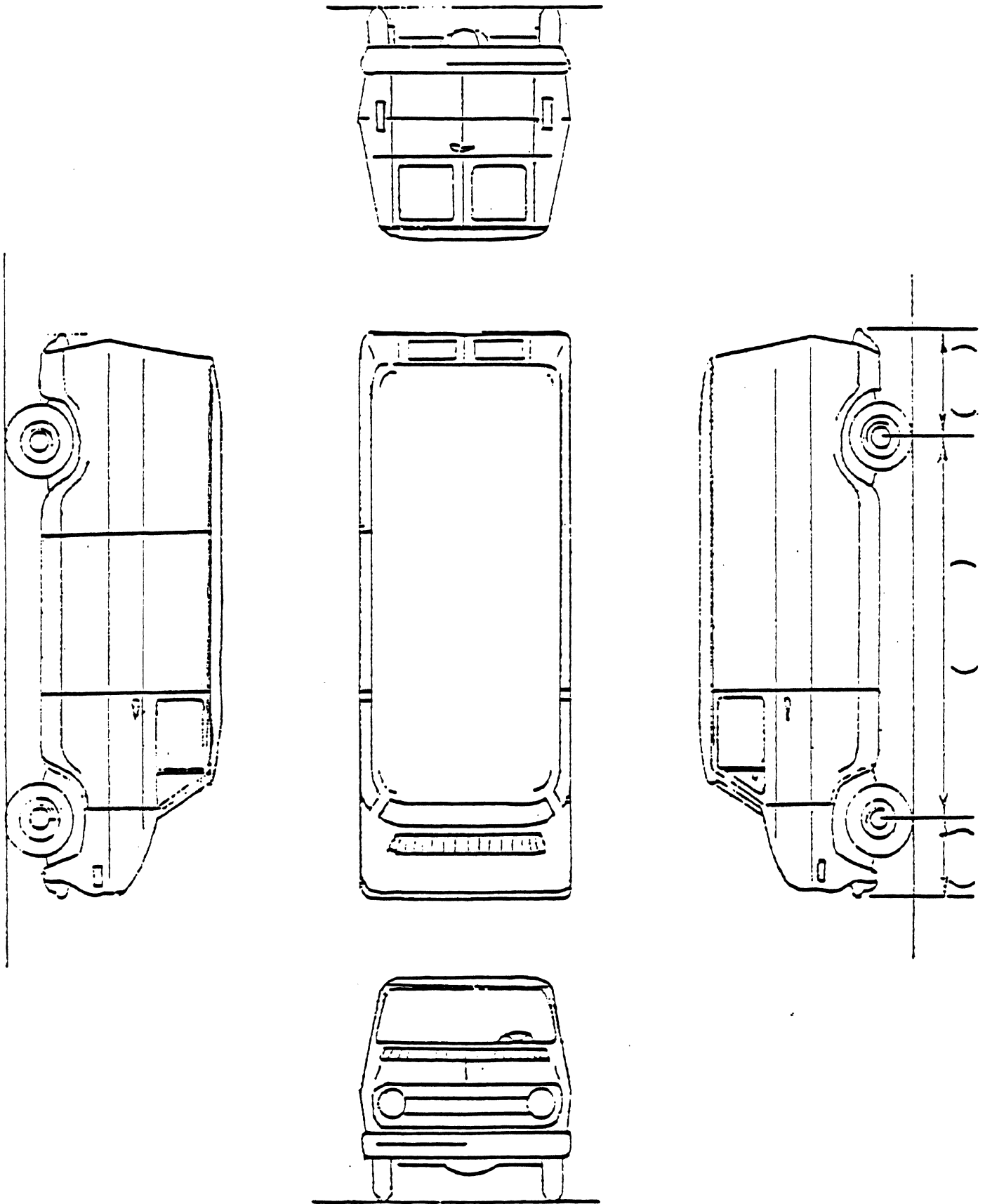

Optional Damage Pictorial Diagram:
Forward-Engine Cargo Van

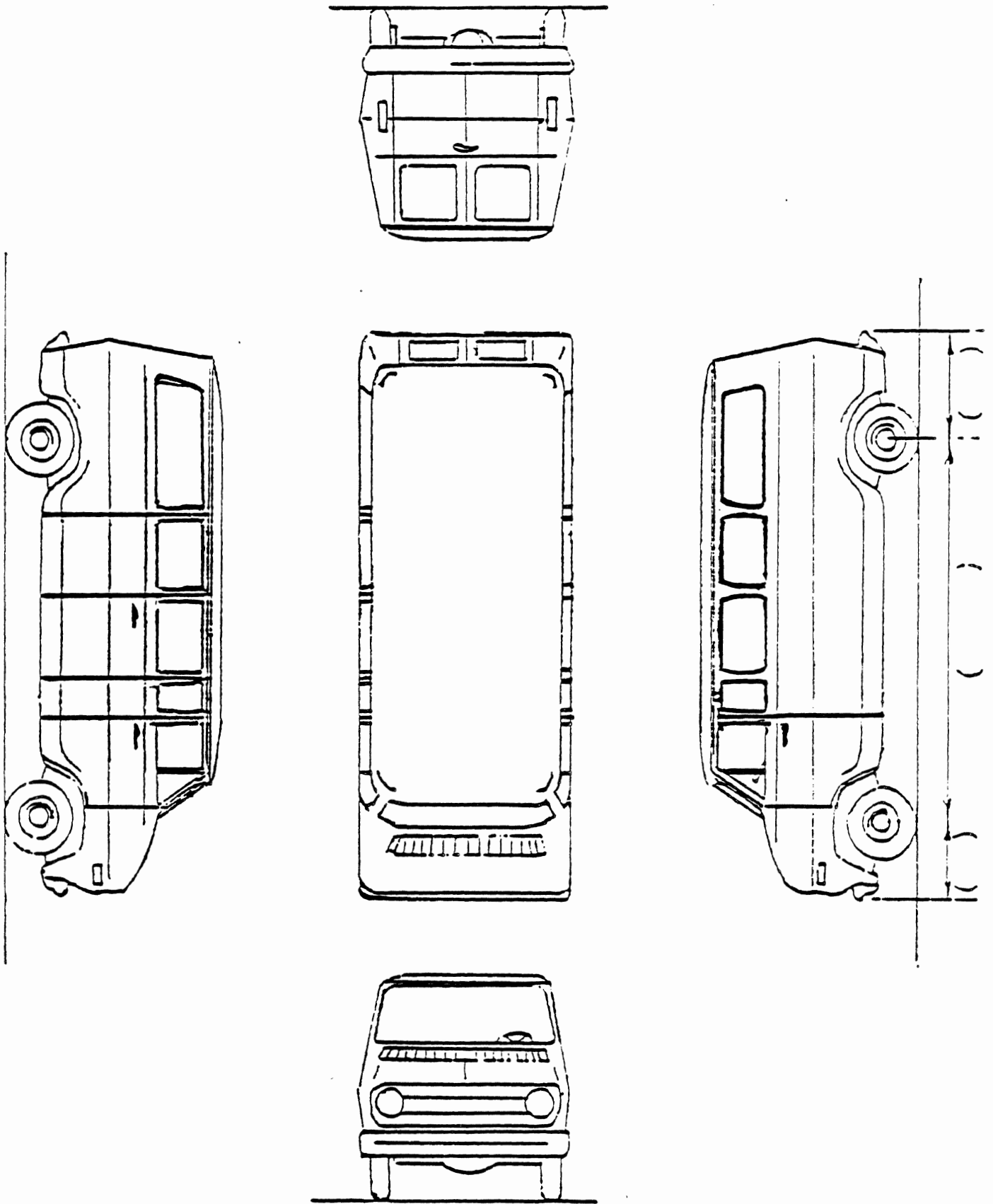

Optional Damage Pictorial Diagram:

Forward-Engine Passenger Van with Hinged Side Rear Doors

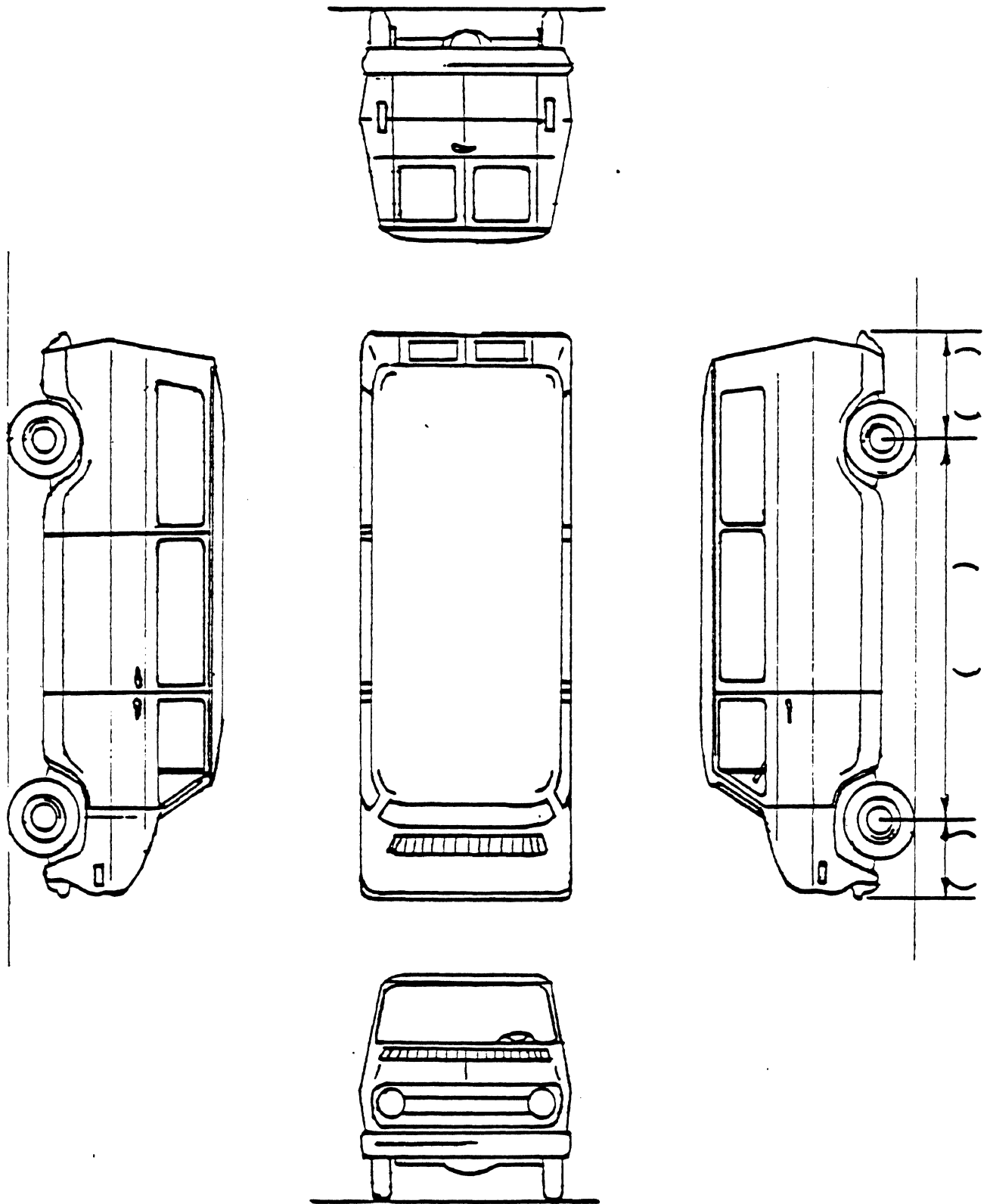

Optional Damage Pictorial Diagram:

Forward-Engine Passenger Van with Sliding Side Rear Door

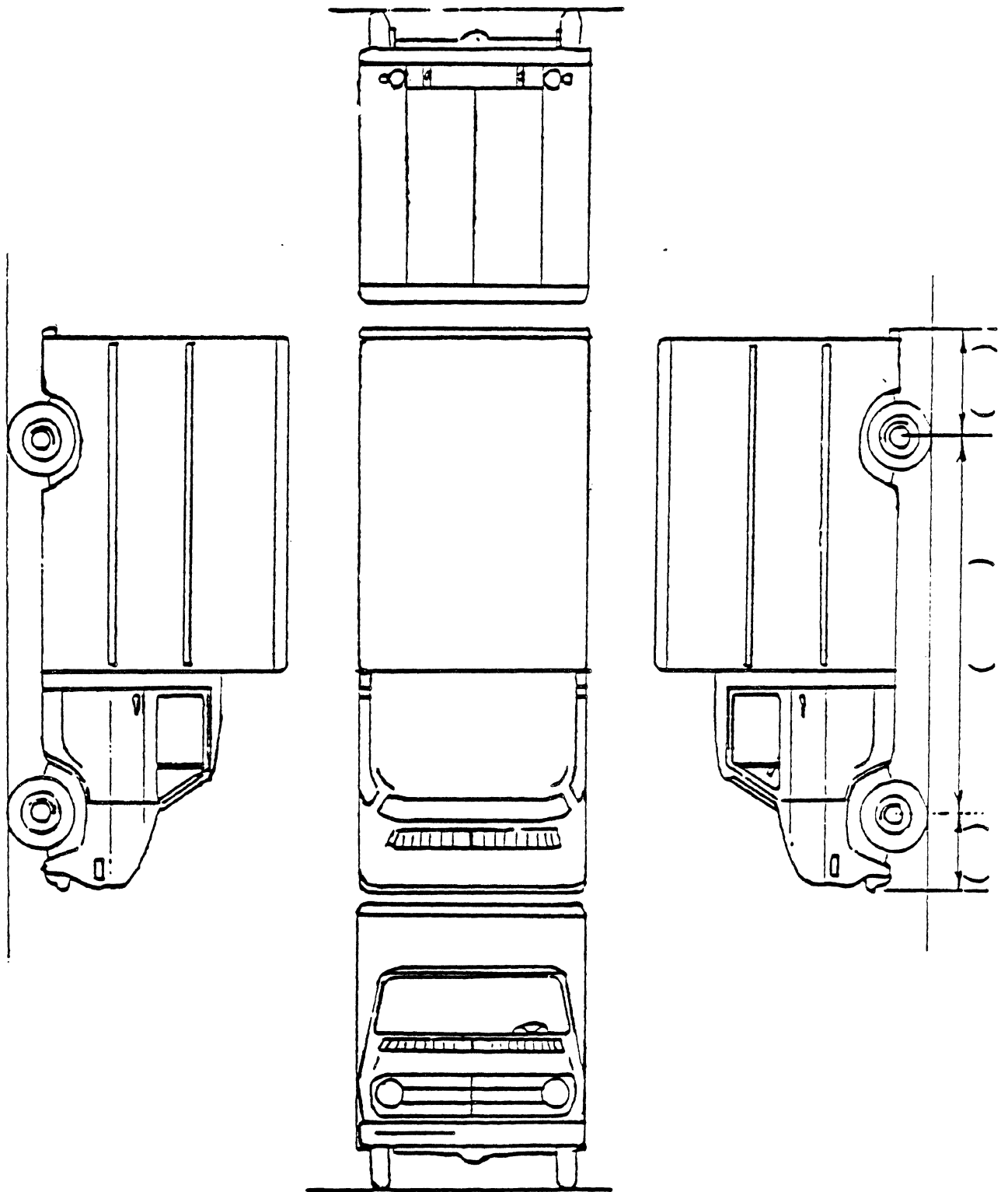

Optional Damage Pictorial Diagram:

Hi-Cube Van

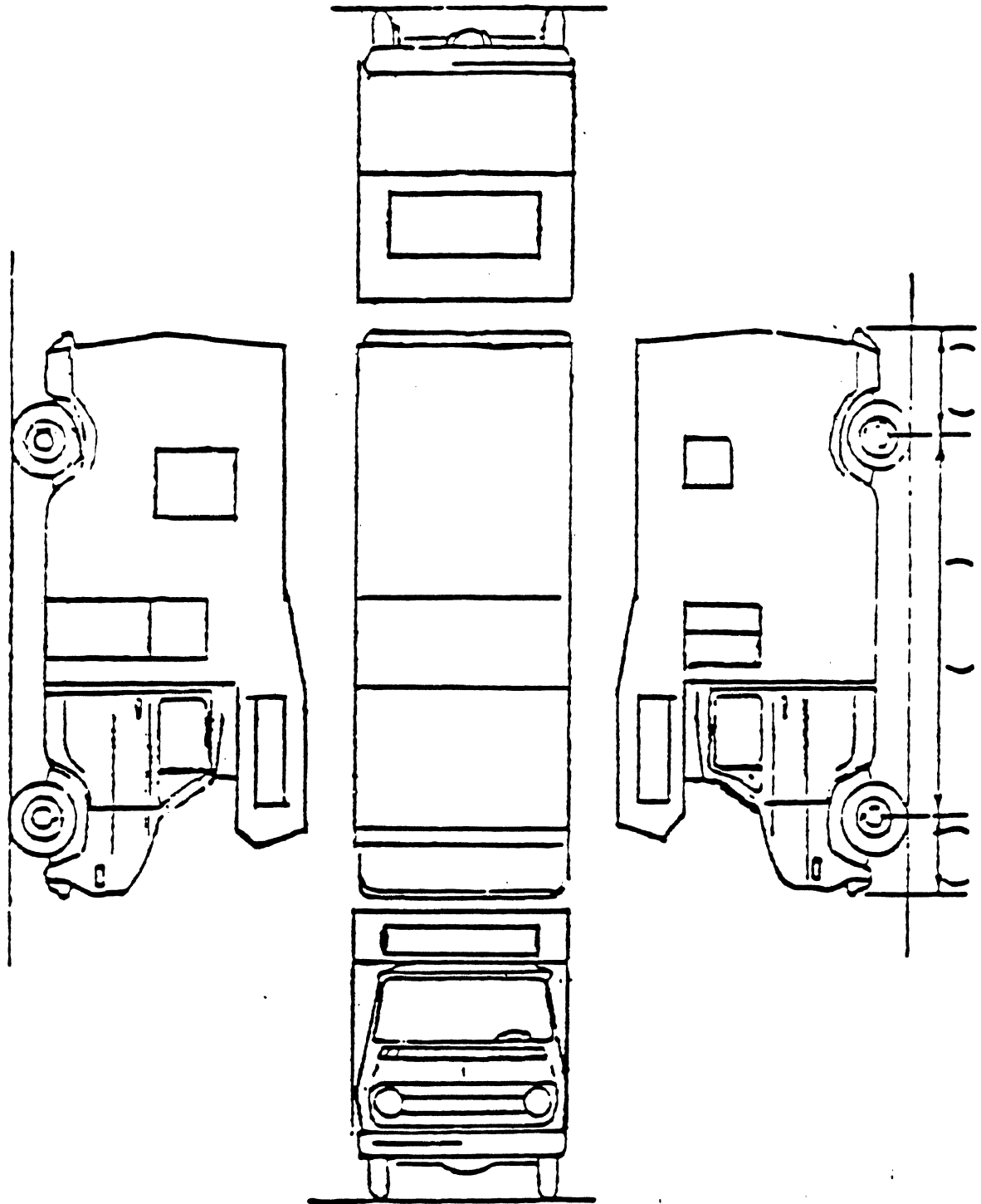

Optional Damage Pictorial Diagram:
Cutaway Van with Motor Home

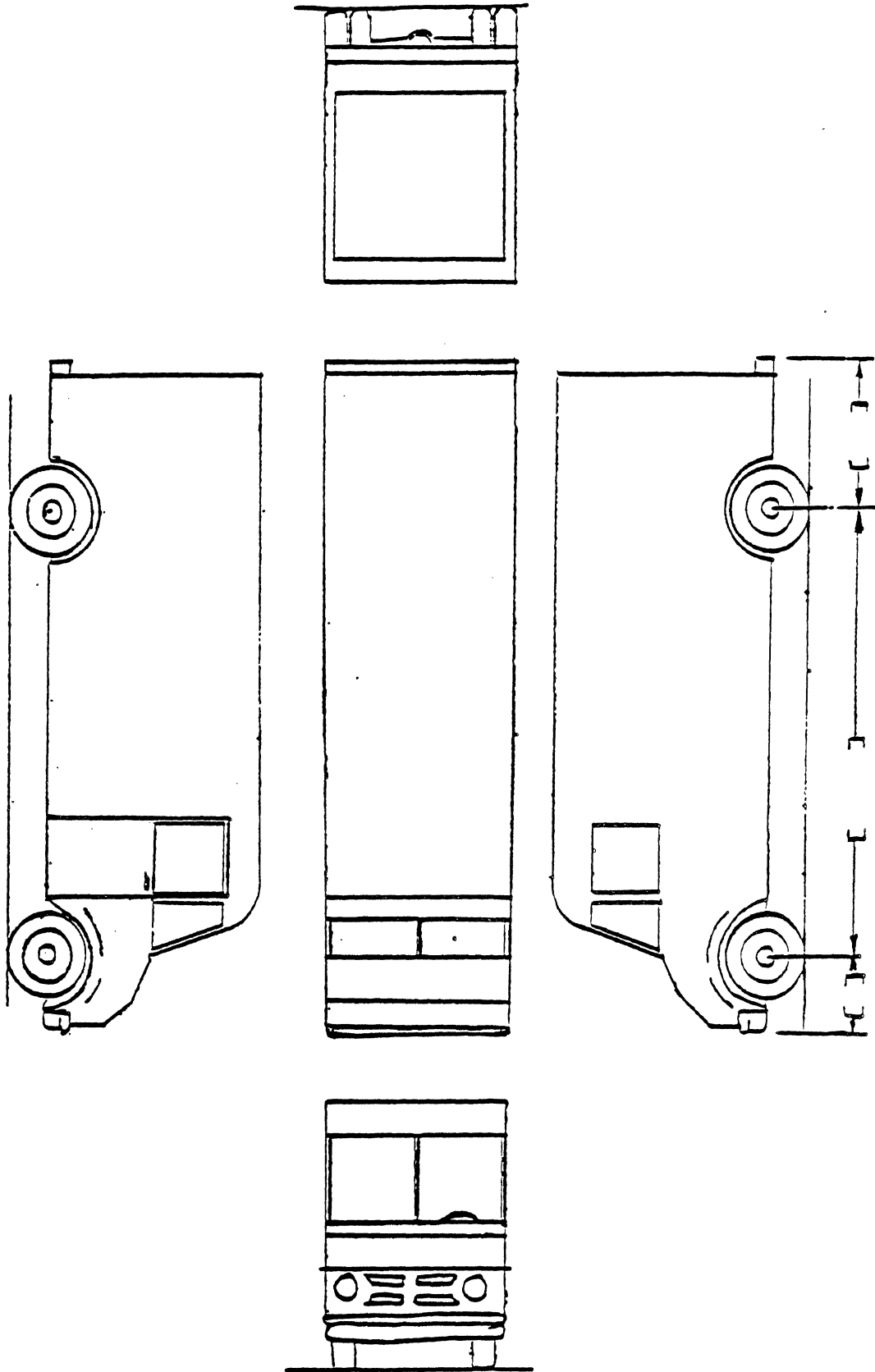

Optional Damage Pictorial Diagram:

Step-Van

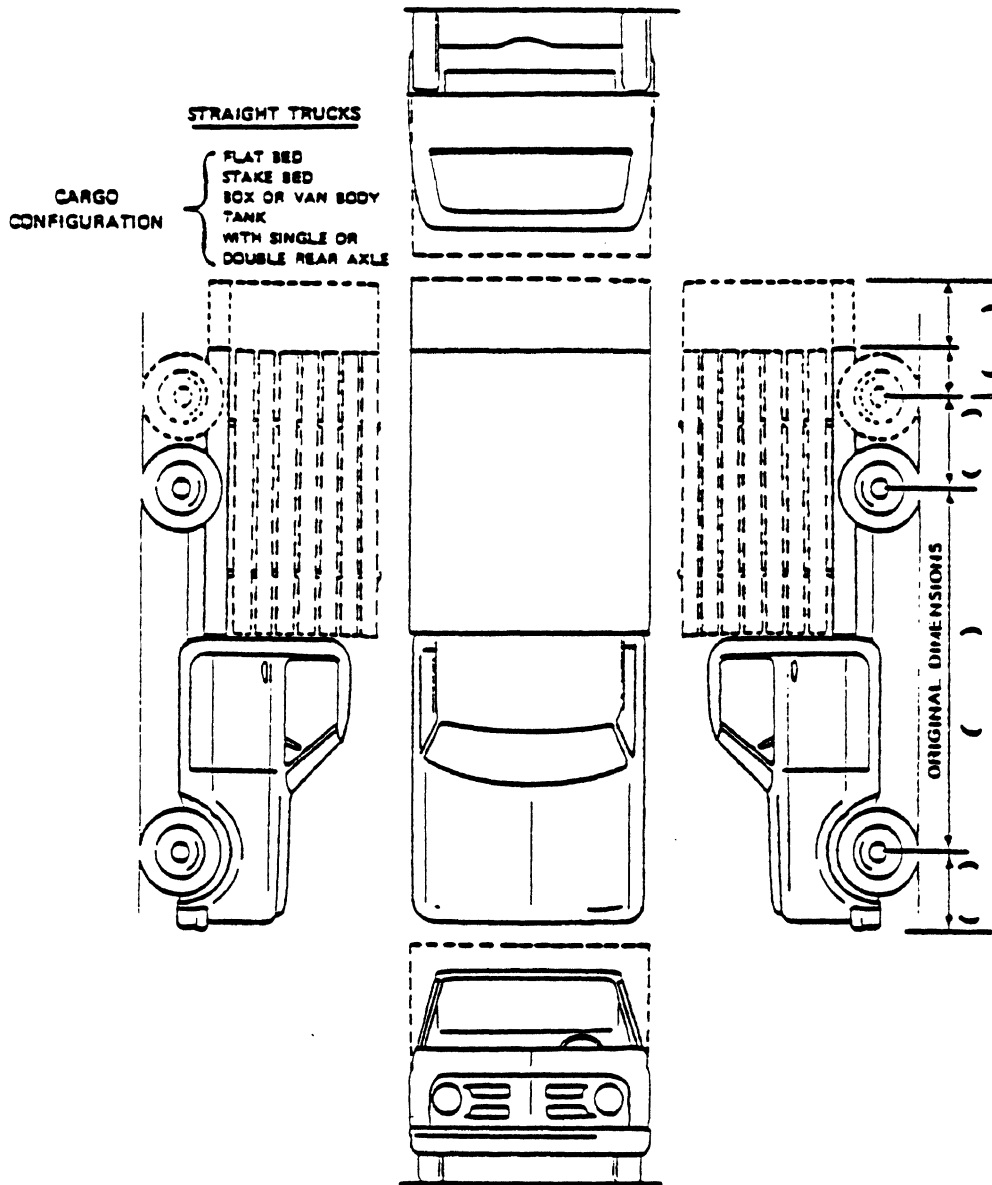

Optional Damage Pictorial Diagram:
General Straight-Truck Pictorial

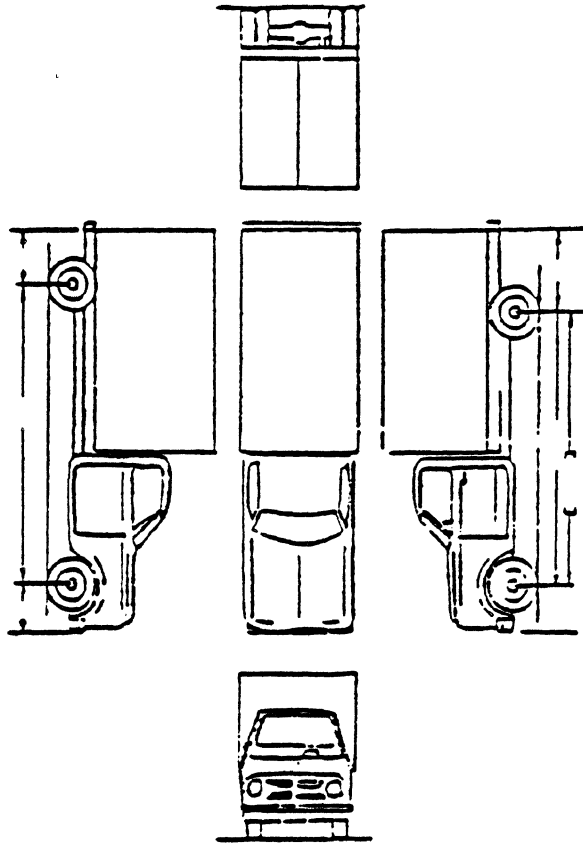

Optional Damage Pictorial Diagram:

Short-Box Straight Truck

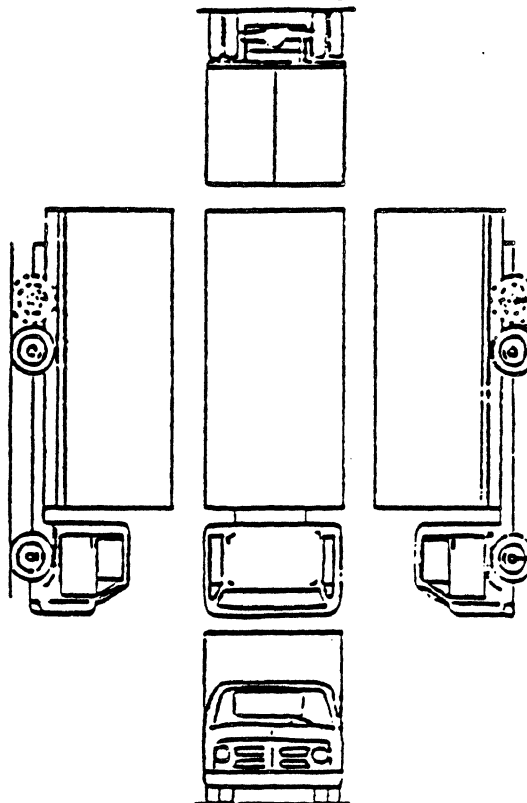

Optional Damage Pictorial Diagram:

Long-Box Straight Truck

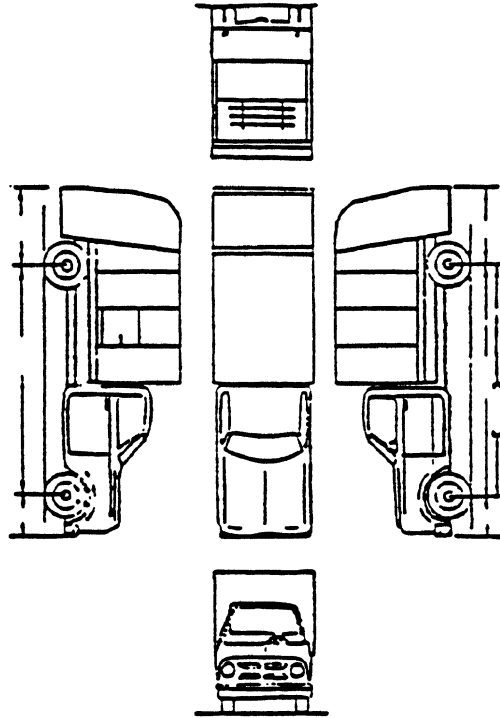

Optional Damage Pictorial Diagram:

Garbage Truck

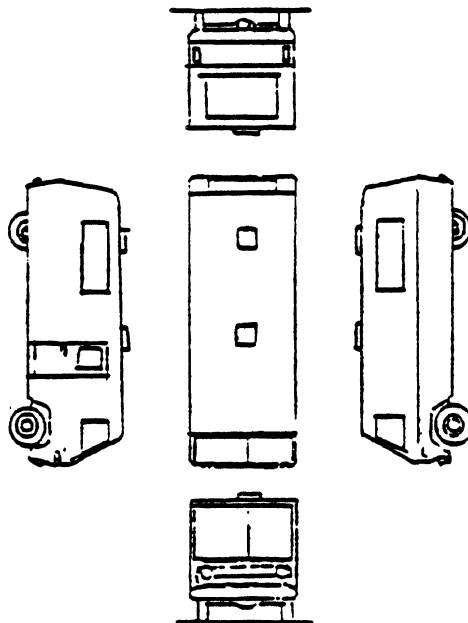

Optional Damage Pictorial Diagram:

Motor Home

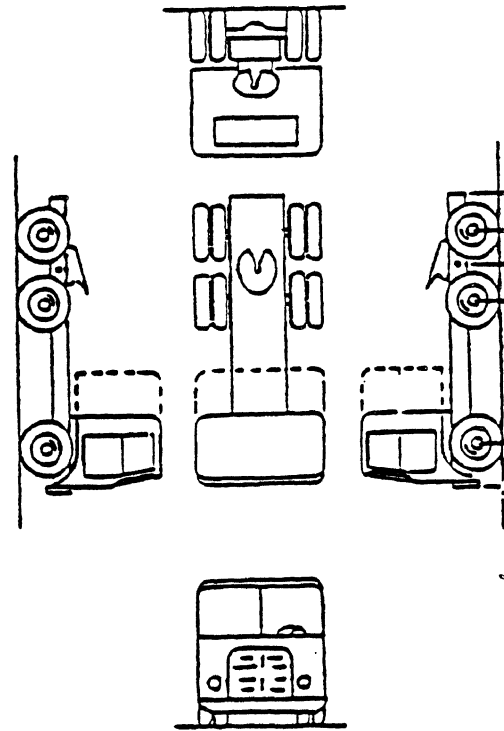

Optional Damage Pictorial Diagram:
Conventional Tractor Alone ("Bobtail")

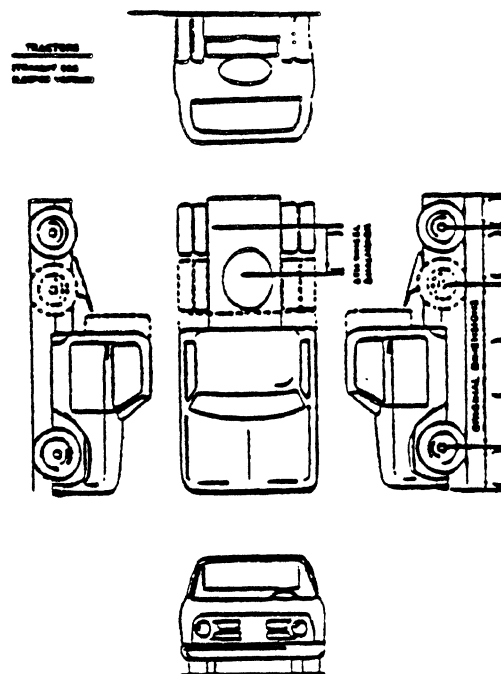

Optional Damage Pictorial Diagram:
Cab-Over-Engine ("COE") Tractor Alone ("Bobtail")

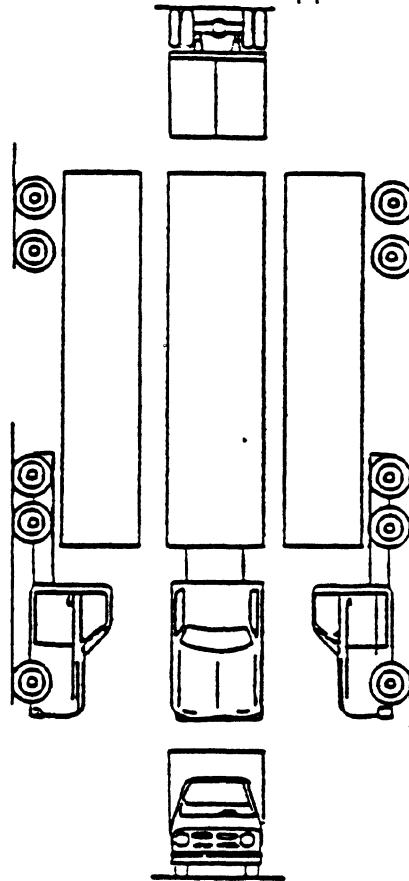

Optional Damage Pictorial Diagram:

Conventional Tractor
with Single-Bottom Semitrailer

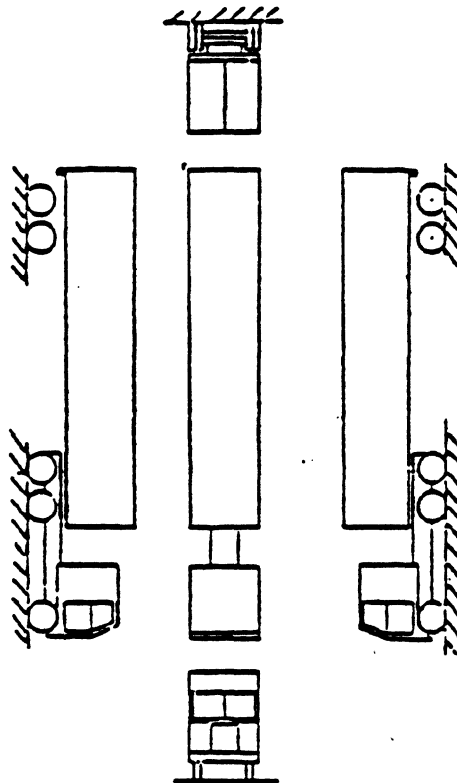

Optional Damage Pictorial Diagram:

Cab-Over-Engine ("COE") Tractor
with Single-Bottom Semitrailer

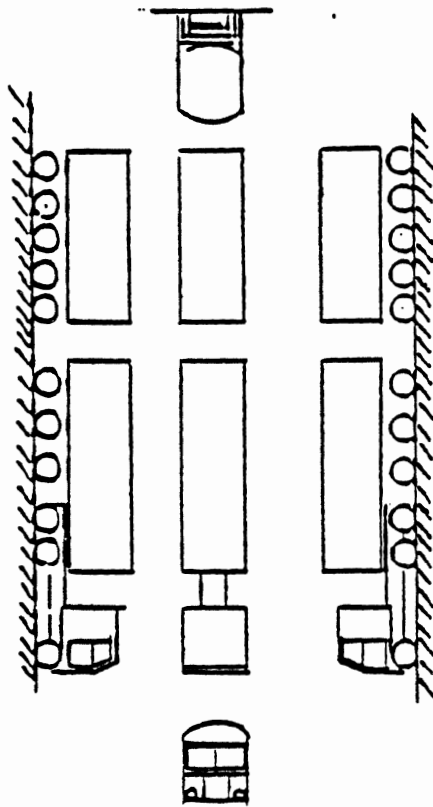

Optional Damage Pictorial Diagram:

Cab-Over-Engine ("COE") Tractor
with Double-Bottom Trailers

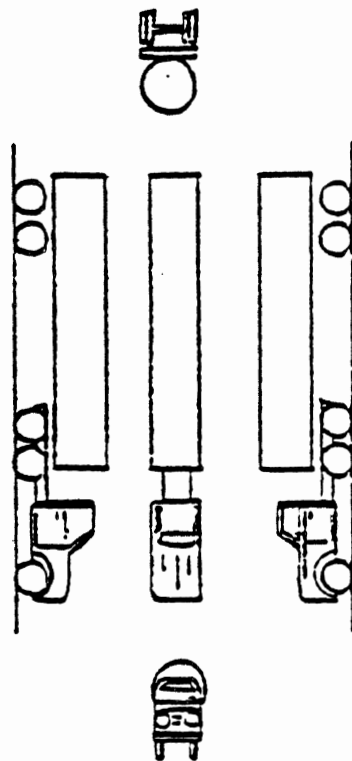

Optional Damage Pictorial Diagram:

Conventional Tractor with
Single-Bottom Tanker Semitrailer

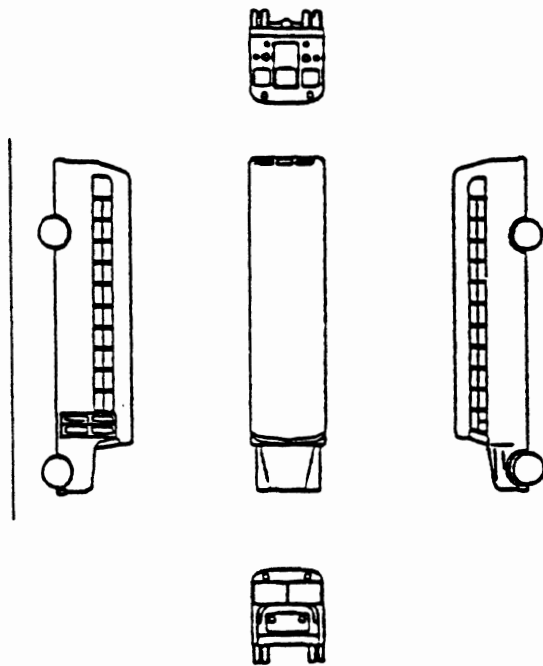

Optional Damage Pictorial Diagram:

Forward-Engine Bus

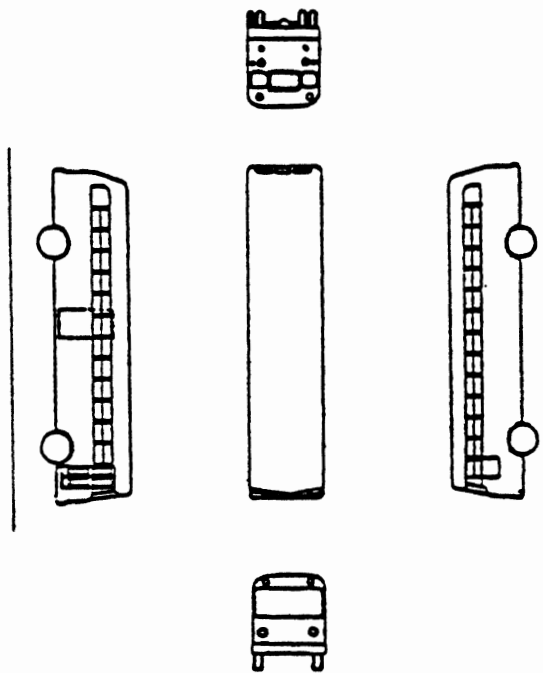

Optional Damage Pictorial Diagram:

Rear-Engine Bus

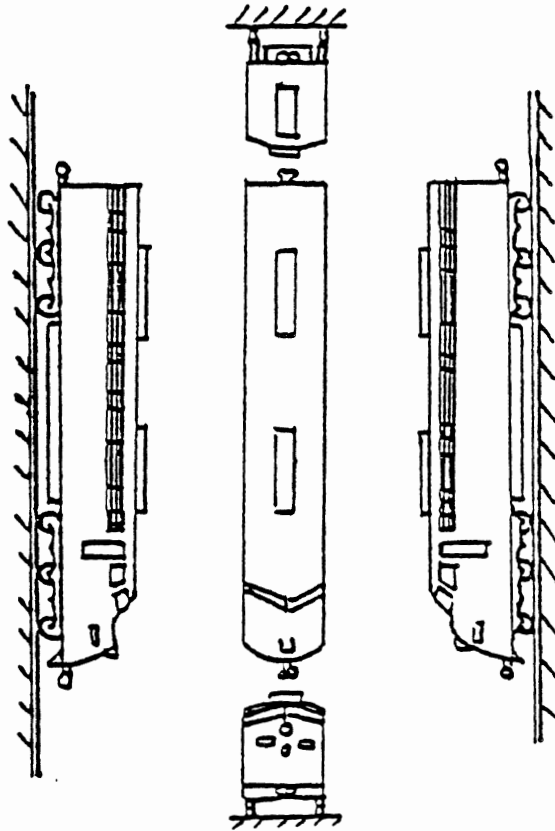

Optional Damage Pictorial Diagram:

Streamliner

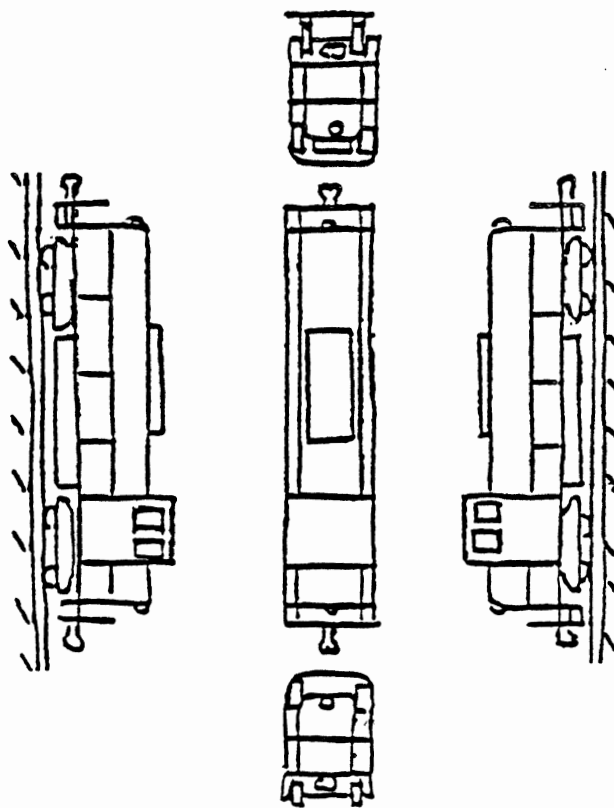

Optional Damage Pictorial Diagram:

Switching Engine

Appendix: PILLAR STRUCTURE

DEFINITION AND INCLUSION OF PILLARS

"Pillars" are the vertical structural components which form the skeletal perimeter of the passenger compartment.

To qualify to be reported on a UMIVOR Form, a pillar must meet one of the following two definitions:

- 1) A pillar must frame a door opening; or
- 2) (For an upper pillar only) a pillar must constitute the rear-most side structural component of the passenger compartment "canopy" (the "greenhouse" or roof-support structure).

Note that this constitutes a change from prior definitions. This change is necessary because of the difficulty encountered in the field distinguishing between a true structural component, and a mere cosmetic "stringer" or other superficial sheet-metal component which provides little structural support.

Prior definitions of "pillar" frequently required that the investigator perform substantial body surgery on a vehicle, if a determination were to be made whether or not a non-door-framing sheet-metal configuration actually had the structural strength to qualify as a pillar. However, this extraordinary effort was rarely performed.

Attempts to obtain a workable, consistent description of "pillar structure" (as it may have differed from one vehicle model to another) have not been successful.

Therefore, to maintain the integrity of the data set being compiled into the computer file, the definition of "pillar" as stated above has been adopted.

Other types of pillars (for instance, the tailgate pillar on a pick-up truck) are not to be recognized; namely, UMIVOR questions about a pillar in that location should be answered "not applicable."

Pillars are labelled alphabetically, sequentially rearward from the forward-most one. Alphabetic designators "A," "B," and "C" are assigned only once, each for a particular vertical longitudinal plane containing a pillar structure. As demonstrated later, a particular pillar need not be present on both the left and right sides. The fourth (if any) and all subsequent pillars are identified as "D-pillars."

The lower pillar starts at the top of the beltline and extends downward to and including its attachment to the lower side rail. The upper pillar starts immediately above the beltline and extends upward to and including its attachment to the roof side rail.

THE "A-PILLAR"

The lower A-pillar usually contains the front-door hinge plate, and the upper A-pillar usually frames the front windshield. If the windshield is folded down (for instance, on a "jeep"-type vehicles), the presence of the upper A-pillar should still be coded. However, if that windshield framework has been removed altogether, then no upper A-pillar is present.

THE "B-PILLAR"

The lower B-pillar usually contains the front-door striker plate. On a two-door vehicle, the upper B-pillar may also frame the side rear window. A "hardtop" has no upper B-pillar. (Some vehicles called "hardtops" by the manufacturers may not meet the UMIVOR criterion for this designation, since some form of upper-B-pillar structural component may be present.)

The lower B-pillar also contains the rear-door hinge or striker plate, if the vehicle has a rear door on that side.

THE "C-PILLAR"

A two-door vehicle has an upper C-pillar only if it frames the rear of the side rear window, or if there is a rear hatchback. A two-door vehicle has no lower C-pillar which qualifies for being recorded on the UMIVOR, unless there is a rear tailgate or a hatchback which extends below the beltline.

On a vehicle which has a rear door on that side, the lower C-pillar contains the rear-door striker or hinge plate.

THE "D-PILLAR"

The D-pillar(s), when present, usually frame in the hatchback or rear gate area. Most conventional passenger cars do not have D-pillars. Exceptions include four-door models with a window behind the side rear door (for instance, some hatchbacks, sedans with "opera windows," and station wagons).

In those cases, the vehicle has an upper D-pillar, but no lower D-pillar unless there is an associated door and latch (following the same criteria as discussed for lower C-pillars in the previous paragraph), or unless there is a tailgate or hatchback.

If there is a rear-most pillar which meets this description of a D-pillar, but there is no C-pillar forward of that location on either the left or the right side of the vehicle, then this rear-most pillar is a C-pillar instead.

PICTORIAL DESCRIPTIONS

The pictorial descriptions on this and the next few pages should help explain the above discussions. The shaded area constitutes the designated pillar.

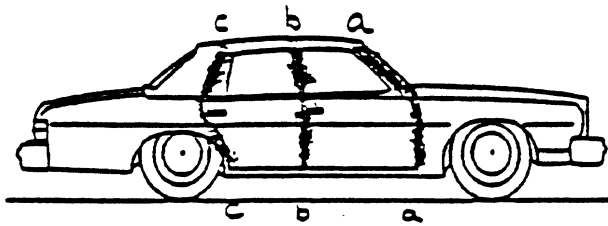

Figure 1:
Conventional Four-Door
Notchback Sedan

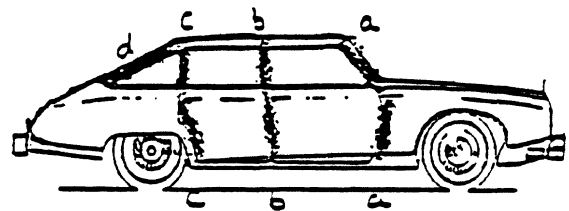

Figure 2:
Four-Door Fastback Sedan
With Rear or "Opera" Window

Figure 1 represents a conventional four-door sedan of the type shown on page VD-3 of the UMIVOR Form.

Figure 2 is for a similar type of sedan, but which has a window on the side behind the rear door opening. If the vehicle has a rear hatch opening which exposes a portion of the passenger compartment below the beltline, there would also be a lower D-pillar.

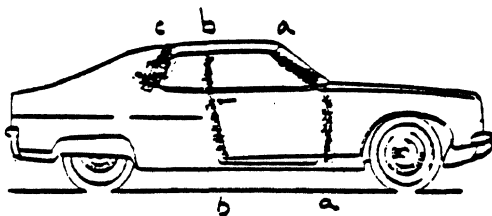

Figure 3:
Conventional Two-Door
Notchback Coupe

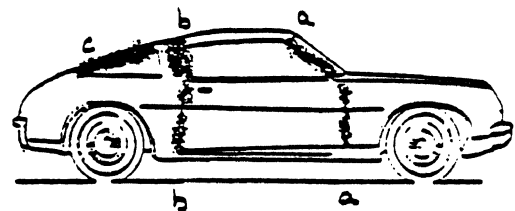

Figure 4:
Two-Door Fastback Coupe

Figure 3 represents a conventional two-door coupe. There is no side rear door, and thus there is no lower C-pillar exposed in the passenger compartment.

Figure 4 represents a two-door fastback coupe with a conventional rear window. If the vehicle has a rear hatch opening which exposes a portion of the passenger compartment below the beltline, there would also be a lower C-pillar.

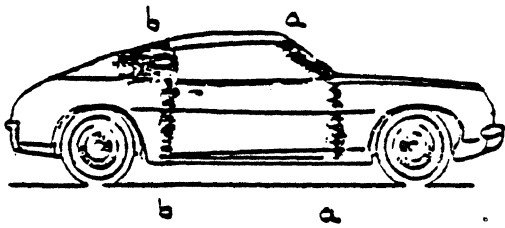

Figure 5:
Two-Door Fastback Coupe
w/Wrap-Around Rear Window

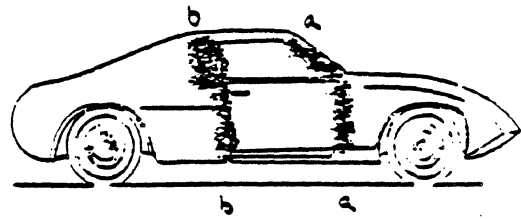

Figure 6:
Two-Door Sport Coupe

Figure 5 represents a two-door fastback coupe with a wrap-around rear window (such as on a Chevrolet Camaro). Note that there is no upper C-pillar in this design.

Figure 6 represents a two-door coupe (including a specialty coupe such as a Chevrolet Corvette) which has no rear window. The entirety of the upper rear flank structure is considered to be a single upper B-pillar.

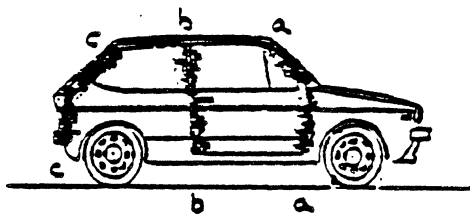

Figure 7:
Two-Door Subcompact
With Rear Hatch

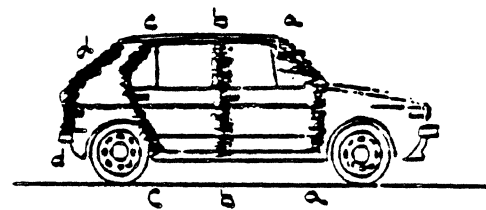

Figure 8:
Four-Door Subcompact
With Rear Hatch

Figures 7 and 8 represent the mini- or subcompact-car type, for instance as characterized by the recent General Motors "X" bodies. Since these vehicles have a rear hatch opening which exposes a portion of the passenger compartment below the beltline, they also have a lower rear-most pillar.

Figures 9 and 10 represent the two-door and four-door types of station wagons. These can be distinguished from the mini-cars in the immediately previous figures by the following guideline:

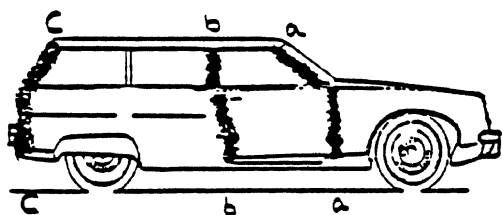

Figure 9:
Two-Door Station Wagon
With Rear Tailgate

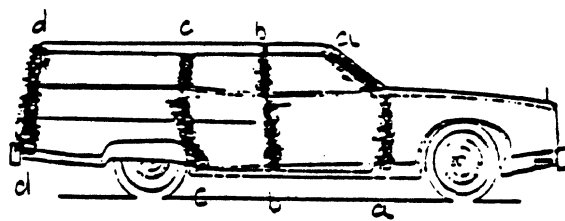

Figure 10:
Four-Door Station Wagon
With Rear Tailgate

If the distance between the rearmost point of the vehicle and the top of the rear window is less than the distance between the top of the rear window and the B-pillar, then the vehicle is a station wagon instead of a hatchback.

Since the rear gate extends below the beltline, there is a lower portion of the rear-most pillar.

Note that in Figure 9, the roof structural support midway between the back of the front door and the rear pillar does not frame a door opening, and thus does not qualify as a pillar for the UMIVOR Form.

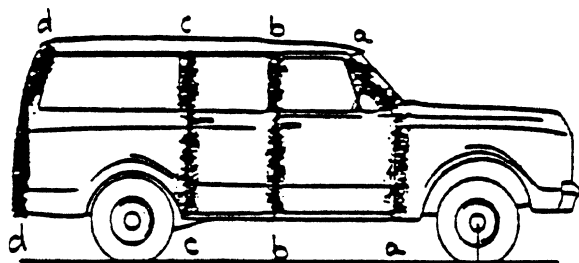

Figure 11:
Four-Door Utility Vehicle
With Rear Tailgate

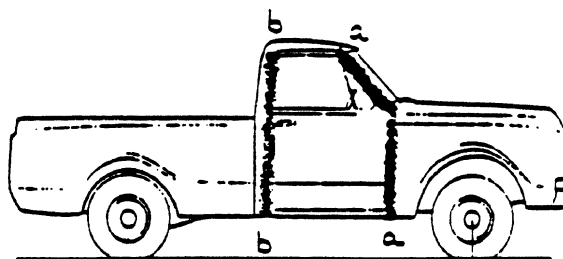

Figure 12:
Conventional Two-Door
Pick-up Truck

Figure 11 represents a long-wheelbase, four-door utility vehicle with a rear tailgate. If the left side of the vehicle has no side rear door, then there is no left-side C-pillar.

For a short-wheelbase, two-door utility vehicle, this same general pictorial would apply, except that the C-pillar would be at the rear of the vehicle. If the vehicle has a roof covering, an upper C-pillar would probably be present, but a lower C-pillar would be present only if there is a rear tailgate. (The Ford Bronco, for an example of this type of vehicle, has no rear tailgate, and thus no lower C-pillar.)

Figure 12 represents a conventional, two-door pick-up truck with no seat or side window behind the front door. Note that the rear-most pillar (the tailgate)

is not coded on the UMIVOR, since it does not enclose a portion of the passenger compartment.

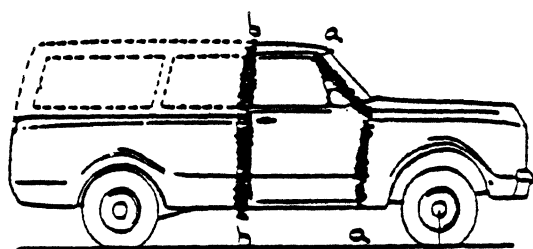

Figure 13:
Two-Door Pick-up With
Rear Shell or Canopy

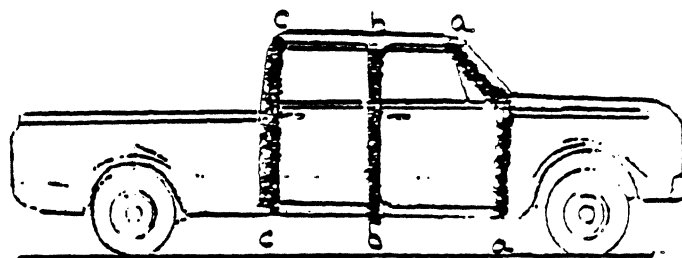

Figure 14:
Four-Door Pick-up Truck

Figure 13 represents a conventional two-door pick-up with no side window behind the front door, but with a rear shell or canopy which encloses an area behind the primary passenger compartment. Pillars behind the B-pillar are not coded in the UMIVOR, because they do not enclose the primary passenger compartment.

Figure 14 represents a four-door pick-up truck (with a "crew cab"). For a more conventional two-door pick-up truck with a side window behind the front door (whether or not there is a seat or storage space present), there is an upper C-pillar, but no lower C-pillar since there is no side rear door.

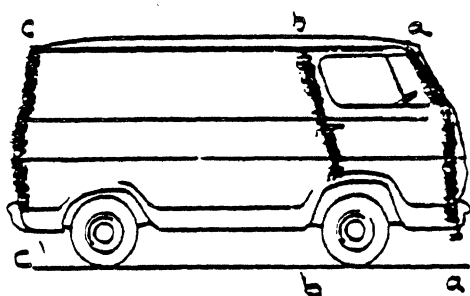

Figure 15:
Two-Door Van
(No Side Rear Door)

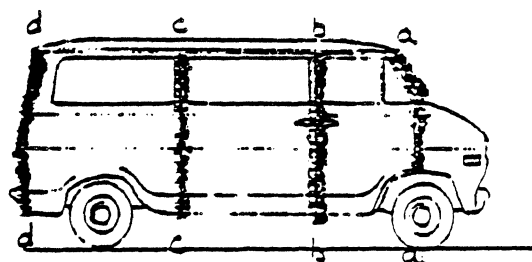

Figure 16:
Three-Door Van (Sliding
or Hinged Side Rear Door)

Figure 15 represents an infrequently found type of van which has no side door behind the front door. There is no C-pillar on either the left or the right side.

Figure 16 represents a more conventional type of van with a side rear hinged or sliding door on the right side. There is a right C-pillar, because there is a right side rear door. However, there is no left C-pillar unless there is also a left side rear door (this is not customary).

Appendix: WINDSHIELD CODES

The following list has been compiled from the best available (but admittedly limited) information.

In the lists on the following pages, "Code Number" refers to the DOT-assigned, two-digit number printed in the glazing monogram. The "M" Number" also appears in that monogram.

The "Alphabetic Code" refers to the two-letter code which is contained in the lists on the next several pages, or which appears in the M.V.M.A. Accident Investigation Manual. This two-letter code is the actual entry to be placed in columns 74 and 75 on page ED-6.

The only numeric entries which may appear in those columns are those shown on page ED-6, for the "uncoded" (97), "not applicable" (98), and "unknown" (99) codes.

The "Original Equipment" alphabetic code should be used when the windshield bears the "Original Mark" monogram, as shown in the following table. If the "Replacement Mark" is present instead, enter the "Service Replacement" code.

TABLE 6

REPLACEMENT WINDSHIELD MONOGRAM MARKS

Original Mark	Replacement Mark		
	PPG	LOF	DCL
Flo-Lite	Float	Float	Float
Soft-Ray	Sun-Shade Solex Duplate	E-Z-Eye	

Code Number, Manufacturer

<u>"M"</u> <u>Number</u>	Alphabetic Code <u>Original</u> <u>Equipment</u>	<u>Service</u> <u>Replacement</u>	<u>Other Notes</u>
15:	LOF (Libby-Owens-Ford)		
3	AB		
4	AT	BQ	
6	AX	BU	
10	TB		
20	AC		
21	AU	BR	
22	AY	BV	
23	AF	BC	
24	AM	BJ	
25	AH	BE	
26	AP	BL	
27	DK	DP	
28	DL	DR	
29	BA	BW	
30	TA		
31	DA	DE	
32	DB	DF	
34	DL	DR	
35	DM	DS	
	YR		Plate, other information unknown
	YS		Float, other information unknown
	YX		LOF, other information unknown

Code Number, Manufacturer

<u>"M"</u> <u>Number</u>	<u>Alphabetic Code</u> <u>Original</u> <u>Equipment</u>	<u>Service</u> <u>Replacement</u>	<u>Other Notes</u>
18: PPG (Pittsburgh Plate and Glass)			
1-2 A	NB		(Opel)
21	AA	DN	
21.1	AD		
22	TD		
23	AS	BP	
23.1	AW	BT	
23.2	AV	BS	
25	AE	BB	
25.1	AJ	BF	
30	AL	BH	
30.2	AQ	BM	(GM)
30.2	BM		(Opel)
32	TC		
52	CA	CE	
52.1	CK	CP	
53	CB	CF	(GM)
53	CD		(AMC)
53.1	CL	CR	
97	CA	CE	
97.1	CK	CP	
98	CB	CF	
98.1	CL	CR	
	YN		Plate, other information unknown
	YP		Float, other information unknown
	YW		PPG, other information unknown
19: DCL (Duplate)			
33	RE		
33.1	RE		
34	AN	BK	(GM '70)
34	EL		(GM '72)
34	RF		?
45	EA		(GM)
45	SA		(AMC)
45.1	EK		
46	EB		(GM)
46	SB		(AMC)
46.1	EL		
53	EA		
53.1	EK		
54	EB		
54.1	EL		
	YM		Float, other information unknown
	YV		DCL, other information unknown

Code Number, Manufacturer

<u>"M"</u> <u>Number</u>	<u>Alphabetic Code</u> <u>Original</u> <u>Equipment</u>	<u>Service</u> <u>Replacement</u>	<u>Other Notes</u>
21: Chrysler			
11	KA		
22	KD		
44	LB		
51	LA		
52	MB		
54	MA		
	YL		Chrysler; other information
	unknown		
22: Guardian			
53	RS		
54	RT		
55	RU		
65	RK		
78	RA, RC, RD		
85	RG, RH		
26: Corning			
15	PA		
16	QA		
32: Lacktex			
3	NE		
5	NG		
36: Sicursn			
1	NF		
46: Crinamex			
21	VA		

Code Number, Manufacturer

<u>"M"</u> <u>Number</u>	<u>Alphabetic Code</u> <u>Original</u> <u>Equipment</u>	<u>Service</u> <u>Replacement</u>	<u>Other Notes</u>
75: Carlite (Ford)			
30	FA		
31	FB		
55	HA		('71)
55	KG		('74-'75)
56	HB		('71)
56	KH		('74-'75)
57	GC		('71)
57	KJ		('74-'75)
58	JA		('71)
58	KN		
59	JB		(Ford '71)
59	NC		(Opel '72)
59	KP		(Ford '74-'75)
60	GH		
61	GB		('71)
61	KD		('74-'75)
62	GI		
63	KE		
73	KF		
78	RB		
80	GD		
81	KL		
82	GA		('71)
82	KM		('74-'75)
90	GE		
91	GF		
92	GG		
93	KR		
95	GJ		
	YK		Unknown Carlite

Appendix: **OIC CODES AND COMBINATIONS**

The Occupant Injury Classification (OIC) is a series of independently defined classification facets which are combined as a sequence of alphanumeric characters to describe an injury in the following terms:

Body Region
Aspect
Diagnosis of Lesion
Body System/Organ
Severity

The following codes may be used for the Body Region entry:

H	Head-Skull	C	Chest (ribs)
F	Face	M	Abdomen
N	Neck	P	Pelvis-Hip
S	Shoulder	Y	Lower Extremities
X	Upper Extremities	T	Thigh
A	Arm (upper)	K	Knee
E	Elbow	L	Leg (below knee)
R	Forearm	Q	Ankle-Foot (toes)
W	Wrist-Hand (fingers)	O	Whole Body
B	Back	U	Unknown

The following codes may be used for the Aspect entry, but only certain combinations of Body Region and Aspect codes are permissible (as listed later in this Appendix):

R	Right	P	Posterior/Back
L	Left	S	Superior/Upper
B	Bilateral	I	Inferior/Lower
C	Central	W	Whole Region
A	Anterior/Front	U	Unknown

The following codes may be used for the diagnosis of lesion:

A	Abrasion	N	Crush
B	Burn	P	Perforation, Puncture
C	Contusion	R	Rupture
D	Dislocation	S	Sprain
E	Severance, Transection	T	Strain
F	Fracture	V	Avulsion
G	Detachment, Separation	O	Other
K	Concussion	U	Unknown
L	Laceration	Z	Fracture with dislocation
M	Amputation		

The following codes may be used for the system or organ entry:

A	Arteries, Veins	M	Muscles
B	Brain	N	Nervous system
C	Spinal cord	O	Eyes
D	Digestive	P	Pulmonary, Lungs
E	Ears	Q	Spleen
G	Urogenital	R	Respiratory
H	Heart	S	Skeletal
I	Integumentary	T	Thyroid, Other Endocrine glands
J	Joints	V	Vertebrae
K	Kidneys	W	All systems in region
L	Liver	U	Unknown

The following codes may be used to indicate severity of injury:

0	None	4	Severe
1	Minor	5	Critical
2	Moderate	6	Maximum
3	Serious	9	Unknown

The following code combinations are valid for Body Region and Aspect:

<u>Body Region:</u>		<u>Aspect:</u>
H	(Head)	R,L,B,P,S,I,W
F	(Face)	R,L,B,P,S,I,W
N	(Neck)	R,L,B,A,P,W
S	(Shoulder)	R,L,B
X,A,E,R,W	(Upper Extremities)	R,L,B
Y,T,K,L,Q	(Lower Extremities)	R,L,B
C	(Chest)	R,L,B,C,W
M	(Abdomen)	R,L,B,C,S,I,W
B	(Back)	S,C,I,W
P	(Pelvis, Hip)	R,L,A,P,W
O	(Whole Body)	R,L,A,P,S,I,W

The following code combinations are valid for sytem/organ shown:

<u>System/Organ:</u>	<u>Lesion:</u>	<u>Aspect:</u>	<u>Body Region:</u>
S	Sketetal	C,F,G,O	* Any except M
(S)	Teeth	F,V,D,Z,O	I F
V	Vertebrae	C,F,S,D,Z,R,O	* N,B,P
J	Joints	F,S,D,G,Z,C,O	* F,P
(J)	Ligaments	F,S,D,G,Z,R,C,O	* S,W,E,Q,K
		L,C,S,T,O	* S,W,E,Q,K
D	Digestive	L,C,V,A,R,P,O	* F,N,M,C
L	Liver	L,C,A,F,V,R,P,O	R,S M
N	Nervous System	L,C,V,P,R,O	* Any except H
B	Brain	L,C,K,V,R,O	* H
C	Spinal Cord	L,C,P,V,R,E,O	* H,N,B,P
E	Ears	L,C,A,V,R,D,B,P,O	R,L,B H
O	Eyes	L,C,A,V,R,B,P,G,O	R,L,B F
	Cardiovascular		
A	Arteries	L,V,R,E,P,O	* Any except H
	Veins		
H	Heart	L,C,R,P,O	C C
Q	Spleen	L,C,F,R,P,O	L M
G	Urogenital	L,C,A,V,P,E,O	I M
K	Kidneys	L,C,A,F,V,P,R,O	R,L,B M
(G)	Bladder	L,C,A,R,P,O	I M
R	Respiratory		
(R)	Trachea	L,C,A,F,V,D,B,N,P,O	A N
(R)	Windpipe	L,C,F,R,B,X,N,P,O	C C
P	Lungs	L,C,F,V,R,P,O	R,L,B C
M	Muscles	L,C,V,R,T,O	* Any Region
I	Skin	L,C,A,B,P,O	* Any Region
W	All Systems	M,N,B,O	* N,S,X,A,E,R,
W,	in region		Y,T,K,L,Q
		N,B,O	* H,N,C,M
		B,O	* F,B,P
(W)Pertitoneum		L,C,P,R,O	* M

"U" ("unknown") is valid in any position in any combination. An asterisk ("*") indicates: see Region/Aspect combination table above.

ANNOTATED BIBLIOGRAPHY

Bibliographic references are listed in four groups:

Vehicle Identification
Vehicle Specifications
Vehicle Damage Reporting
Medical and Physiological Conditions

Within each of these four, those items which should be acquired by each field investigator and editor are indicated by an asterisk (*). The remaining items contain supplemental information or discussion, or pertain to specialized areas of concern.

VEHICLE IDENTIFICATION

*Passenger Vehicle Identification Manual. National Automobile Theft Bureau, Palos Hills, Illinois.

Published annually, this "VIN Manual" is useful in corroborating VIN structures, and in defining certain vehicle-model and option-package parameters based on the VIN structure and contents. Information is provided on both domestic and foreign vehicles.

Commercial Vehicle Identification Manual. National Automobile Theft Bureau, New York, New York, 1973.

This was the first edition of the commercial-vehicle equivalent to the immediately preceding item. Later revisions may be available, but this Manual was not intended to be re-issued annually.

Federal Motor Vehicle Safety Standard Number 115: Vehicle Identification Number.

"This (FMVSS) standard specifies requirements for a vehicle identification system to simplify vehicle information retrieval and to reduce the incidence of accidents by increasing the accuracy and efficiency of vehicle defect recall campaigns."

FMVSS Standard No. 115, paragraph S1.

VEHICLE SPECIFICATIONS

Accident Investigation Manual; Passenger Cars, Multi-Purpose Vehicles, Motor Trucks. Motor Vehicle Manufacturer's Association, Detroit, Michigan.

This Manual was published annually by the MVMA, and contains most of the information required about any domestically manufactured passenger vehicle which would be reported as a Case Vehicle on a UMIVOR Report.

Red Book. National Market Reports, Inc., Chicago, Illinois.

The Red Book contains information (including a VIN summary) on each make, line, series, and model of passenger vehicle manufactured for domestic sale in the United States. Updated eight times each year, the Red Book is intended primarily as a guide for used-car evaluations. However, this publication is also useful for determining the shipping weight of these vehicles (as required on the UMIVOR Report), and for verifying the existence of certain model options (engine size, body styles, etc.).

Canadian Red Book. National Market Reports, Inc., Chicago, Illinois.

Although this version of the Red Book contains many duplications from the version cited immediately above, it also contains information on passenger vehicles of Canadian manufacture which are not intended for U.S. resale, and thus have not been listed in the regular Red Book. For the investigation of Canadian accidents, this reference item should certainly be used.

Truck Blue Book. National Market Reports, Inc., Chicago, Illinois.

This is the truck version of the conventional Red Book, although it also duplicates information about light trucks (pickups, vans, and other multi-purpose passenger vehicles). This reference also contains information about truck VIN's (including those of light-duty trucks also covered by the conventional Red Book).

Tire Guide. The Tire Information Center, Commack, New York.

This Guide is published annually, and lists the standard and optional tire sizes for each vehicle manufactured for sale in the U.S. Also included are designations of rim size, maximum inflation ratings (for use on the particular vehicle), and a cross-listing of interchangeable tire sizes.

VEHICLE DAMAGE REPORTING

SAE J224MAR80: Collision Deformation Classification. Society of Automotive Engineers, Inc., Warrendale, Pennsylvania, 1980.

This "SAE Recommended Practice" is published in the annual SAE Handbook. It constitutes the current, official discussion and interpretation of the use of the "Collision Deformation Classification" ("CDC").

SAE J1301: Truck Deformation Classification. Society of Automotive Engineers, Inc., Warrendale, Pennsylvania, 1980.

This "SAE Recommended Practice" is also published in the annual SAE Handbook. It is the large-truck equivalent of the CDC standards in SAE J224 MARCH 80.

*CRASH 3 User's Manual. DOT-HS-805 732, National Highway Traffic Safety Administration, Accident Investigation Division, Washington, D.C., February, 1981

(Abstract:)

The CRASH computer program is an accident investigation aid aimed at achieving improved accuracy and uniformity in the interpretation of physical evidence from automobile accidents. The program can provide estimates of impact speeds and speed changes on the basis of two separate analytical techniques. ... This report contains detailed instructions for users of the CRASH computer program.

MEDICAL AND PHYSIOLOGICAL CONDITIONS

*The Abbreviated Injury Scale (1985 Revision). American Association for Automotive Medicine, Arlington Heights Illinois, 1985.

This document is the latest revision of the AIS, and supersedes earlier versions. It is absolutely essential for injury coding.

Baker, S.P.; O'Neill, B.; Haddon, W., Jr.; and Long, W.B. "Injury Severity Score: A Method for Describing Patients with Multiple Injuries and Evaluating Emergency Care." Journal of Trauma, Volume 14, Pages 187-196, 1974.

This paper may be used for a more detailed explanation of the development of the ISS.

Marsh, J.C. "Existing Traffic Accident Injury Causation Data Recording Methods and the Proposal of an Occupant Injury Classification Scheme." Proceedings of the Sixteenth Conference of the American Association for Automotive Engineers, New York, October 19-21, 1972.

Marsh, J.C. An Occupant Injury Classification Procedure Incorporating the Abbreviated Injury Scale. Presented to the NATO Committee on the Challenges of Modern Society, Road Safety Pilot Study, Accident Investigation Final Workshop, Brussels, Belgium, June 28-29, 1973.

*Petrucelli, Elaine; States, J.D.; Huelke, D.F.; and Hames, Lee N. Injury Coding Manual, Revised Edition, 1983. DOT-HS-9-02233, Institute for Research in Public Safety, Indiana University, Bloomington, Indiana, 1983.

This Manual is the latest updated OIC directory, incorporating the AIS-80. It contains medical diagrams and definitions, and is an invaluable resource for injury coding.