

NSRP

March 1991
NSRP 0322

NATIONAL SHIPBUILDING RESEARCH PROGRAM

The Movement and Storage of Pipe and Shapes

U.S. DEPARTMENT OF TRANSPORTATION
Maritime Administration and the U.S. Navy

in cooperation with
National Steel and Shipbuilding Company
San Diego, California

The Movement and Storage
of
Pipe and Shapes

Task: N-1-87-3

Submitted to:

National Steel and Shipbuilding Company
under NASSCO P.O.# MU124557-D

March 29, 1991

Principal Investigators:
Albert W. Horsmon, Jr. and Howard M. Bunch
The University of Michigan
Transportation Research Institute
Marine Systems Division
Ann Arbor, Michigan 48109-2150

1. Report No. NSRP-0322		2. Government Accession No.		3. Recipient's Catalog No.	
4. Title and Subtitle THE MOVEMENT AND STORAGE OF PIPE AND SHAPES				5. Report Date March 1991	
				6. Performing Organization Code	
7. Author(s) The Marine Systems Division				8. Performing Organization Report No. UMTRI--91-14	
9. Performing Organization Name and Address The University of Michigan Transportation Research Institute 2901 Baxter Road, Ann Arbor, Michigan 48109				10. Work Unit No. (TRAIS)	
				11. Contract or Grant No. NASSCO PO#MU124557-D	
12. Sponsoring Agency Name and Address National Steel and Shipbuilding Co. (NASSCO) Harbor Drive and 28th St., Box 85278 San Diego, CA 92138				13. Type of Report and Period Covered Technical Report	
				14. Sponsoring Agency Code DOT-MarAd-1-87-3	
15. Supplementary Notes NASSCO was the managing sponsor of the research for this report with the Maritime Administration of the U.S. Department of Transportation. The project was performed as part of the National Shipbuilding Research Program managed research.					
16. Abstract Movement and storage of pipe and shapes is investigated. The investigators draw on data gathered from shipyards, material distributors and manufacturers to explain the problem and to develop viable solutions. Applicable literature on material handling in general, and pipe and shape handling in particular, is reviewed. General principles of material handling are analyzed for application to the subject materials. A system is described for classifying pipe and shapes into unit loads and the attributes of various moving and storing devices are described. Finally, a methodology is presented for analyzing a material handling system and choosing the best alternatives. A case study is used to explain the model.					
17. Key Words Shipbuilding, material handling, pipe, pipe handling, structural shapes, shape handling, pipe storage, shape storage.				18. Distribution Statement	
19. Security Classif. (of this report) Unclassified		20. Security Classif. (of this page) Unclassified		21. No. of Pages 107	22. Price

MOVEMENT AND STORAGE OF PIPE AND SHAPES

CONTENTS

I.	INTRODUCTION.....	1.
II.	PROBLEM DEFINITION	4.
III.	REVIEW OF PREVIOUS STUDIES AND LITERATURE.....	9.
IV.	PRINCIPLES OF MATERIAL HANDLING	17.
V.	UNIT LOAD DEFINITION.....	24.
VI.	ANALYSIS OF MOVEMENT AND STORAGE METHODS.	29.
VII.	MATERIAL HANDLING SYSTEM DESIGN	48.
VIII.	CASE STUDY	62.
IX.	SUMMARY AND CONCLUSIONS	75.
X.	REFERENCES	79.
XI.	APPENDIX.....	81.
	A. Industrial Truck Association.....	A1-1
	B. Material Handling Institute Member List	B1-1
	1. Automated Storage/Retrieval Systems.....	B1-2
	2. Conveyor Section	B2-1
	3. Crane Manufacturers Association.....	B3-1
	4. Industrial Metal Containers Section.....	B4-1
	5. Plastic Products Section	B5-1
	6. Rack Manufacturers Institute	B6-1
	7. Shelving Manufacturers Association.....	B7-1
	C. Storage Building.....	C1-1

FOREWORD

This report is a product of a program directed by the National Shipbuilding Research Program (NSRP) and the Ship Production Committee (SPC) of the Society of Naval Architects and Marine Engineers (SNAME). This particular research project was funded by the Maritime Administration (MARAD) of the United States Department of Transportation (DOT) as prime contractor and National Steel and Shipbuilding Company (NASSCO) as subcontractor and direct contract administrator under NASSCO PO No. MU124557-D.

Appreciation is expressed to the following people for their assistance in providing information for this report:

Mike Mako, USX, South Chicago, IL,
Kevin Linauer, La Barge Pipe and Tube, St. Louis, MO,
Randy Missel and Susan Salata, NASSCO, San Diego, CA,
Michael Atwood, Livingston Pipe and Tube, Staunton, IL.
Michael Schultz, UNITEC Construction Services, Ann Arbor,
MI.
Lee Cooper, Oxytechnik USA, Wilmington, DE.
Gary Peters, Pettibone, Baraga, MI.
Frank Flemmens, Acco Products, York, PA.
Steve Maguire, Avondale Shipyard, New Orleans, LA.
Gary Gajdzik and Dick Gorman, USS/Kobe Steel, Lorain, OH.
Robert Hillstrom, Southwest Marine, Inc.

The study was performed at the University of Michigan Transportation Research Institute by Albert W. Horsmon, Jr. and Brant R. Savander, assisted by graduate student Bryant Bernhard. Howard M. Bunch was project director.

THE MOVEMENT AND STORAGE OF PIPE AND SHAPES

I. INTRODUCTION

The movement and storage of pipe and shapes in many shipyards may be a function that is in need of continual process improvement. Handling these cumbersome objects is an unavoidable task in the construction and repair of any vessel. The Facilities and Environmental Effects Panel (SP-1) of the Ship Production Committee of SNAME has identified the efficient handling of pipe and shapes as a critical element in the pursuit of an efficient and productive shipbuilding initiative.

The traditional method for handling any item in a shipyard is to use available equipment in an "efficient" manner. The method of equipment utilization is continually being altered to optimize this "efficiency."

This report is structured to analyze the issues related to the movement and storage of pipe and shapes. Section II defines problems involved with material handling in general, and movement and storage of pipe and shapes in particular. The section also summarizes the findings of the literature search.

Section III reviews many of the previous NSRP reports, and other literature, to develop the background and basis for this study. This review also serves to provide an additional reference source for dealing with pipe and shapes movement in the marine construction industry. Problems experienced in material handling in general and pipe and shapes handling in particular are discussed.

Section IV discusses general material handling principles. These principles provide guidelines for those involved in the design and analysis of existing and possible alternative systems.

Section V describes the benefits of using unit loads to characterize the machinery and materials in a handling system. A unit load code for pipe and shapes is proposed.

Section VI describes the attributes of the various types of movement and storage devices. Fork trucks, straddle carriers, lifter loaders, cranes

and other machines are investigated. Storage hardware and software devices are also investigated. Cantilever racks, pallet racks, bar code readers and printers, and specialty accessories are described in this section.

Section VII implements the information developed in the previous sections. A "generic" shipyard is developed to serve as a basis for any shipyard material manager looking at the movement and storage needs of his or her particular yard. A methodology is described for analyzing pipe and shapes material handling problems. The body of the report describes the over-all methodology, while a specific case study is presented in Section VIII. This case study utilizes concepts developed by manufacturers of pipe and structural shapes, harvesters and distributors of timber, and general material handling specialists.

Some of the material handling problems discussed in this study are best solved by a distinct type of machinery. Often this machinery is described by brand name and model as the best solution to a particular phase of a handling situation. There was no intention on the part of the investigators to endorse any brand or make of machinery, nor does this indicate an endorsement of any manufacturer by any organization associated with these studies.

The appendices list the many sources of information used by the investigating team.

II. PROBLEM DEFINITION AND METHOD OF APPROACH

Pipes come in various diameters, wall thicknesses and materials. Structural shapes come with similar attributes plus the added variable of different shapes. Some of the many attributes that need to be considered for handling pipe and shapes are shown in Table II-1 and II-2, respectively.

Table II-1
PIPE ATTRIBUTES

MATERIAL	DIAMETER	SIZE WEIGHT ¹	LENGTH ²	ALLOY ³	COATING	PACKAGING
STEEL	<2"	40,80,120	20,SRL	A1,A2, A3	PAINT/ OTHER	BUNDLES
STEEL	>2" , <12"	40,80,120	20,SRL,DRL	A1,A2, A3	PAINT/ OTHER	LOOSE BUNKS
STEEL	>12"	40,80,120	20,SRL,DRL	A1,A2, A3	PAINT/ OTHER	LOOSE BUNKS
CRES ²	< 2"	80,120	20	A4,A5, A6	N/A	BUNDLE/BOX
CRES	> 2"	80,120	20	A4,A5, A6	N/A	BUNDLES
ALUMINUM	<3"		20	A7,A8	MILL/PAINT	BUNDLES
ALUMINUM	>3"		20	A7,A8	MILL/PAINT	BANDED
COPPER	< 2"		20	N/A	N/A	BUNDLE/BOX
COPPER	>2"		20	N/A	N/A	BUNDLE/BOX
CU-NI	< 2"		20	A9,A10	N/A	BUNDLE/BOX
CU-NI	> 2"		20	A9,A10	N/A	BUNDLE/BOX
FRP	< 4"		20,40	A11,A12	A,B	BUNDLE
FRP	> 4"		20,40	A11,A12	A,B	LOOSE BUNKS

source: Study Team

¹Numbers in the Weight column refer to standard iron pipe size (IPS), weight schedules, pipe schedules (sizes).

²Refers to possible code designations for the various strengths of pipe.

³CRES refers to corrosion resistant pipe.

The scope of the problem definition was limited to moving pipe and shapes from the delivery vehicle to storage, possibly to and from a pre-processing site, and then to the initial production processing location. It generally does not include movement or storage in the pipe or steel fabrication shops, although some methods discussed for bulk storage may be adapted to in-process storage. For pipe, it included handling spools out of the shop and into the first outfitting stage, including handling involved for kitting. Kitting is the grouping of pipe spools into outfit packages ready for zone outfitting.

Table II-2
SHAPE ATTRIBUTES

MATERIAL	PRODUCT	ALLOY ⁴	SIZE		FINISH
			LENGTH ⁵	WEIGHT/FT ⁶	
STEEL	FLAT BAR	A,B,C	1,2,3	7,8,9	COATED/NOT
STEEL	ANGLE	A,B,C	1,2,3	7,8,9	C/NC
STEEL	CHANNEL	A,B,C	1,2,3	7,8,9	C/NC
STEEL	TEE	A,B,C	1,2,3	7,8,9	C/NC
STEEL	PIPE	A,B,C	1,2,3	7,8,9	C/NC
STEEL	I-BEAM	A,B,C	1,2,3	7,8,9	C/NC
STEEL	WIDE I-BEAM	A,B,C	1,2,3	7,8,9	C/NC
STEEL	OTHER BARS	A,B,C	1,2,3	7,8,9	C/NC
STEEL	SQUARE TUBE	A,B,C	1,2,3	7,8,9	C/NC
ALUMINUM	FLAT BAR	D,E,F	4,5,6	10,11,12	C/NC
ALUMINUM	ANGLE	D,E,F	4,5,6	10,11,12	C/NC
ALUMINUM	CHANNEL	D,E,F	4,5,6	10,11,12	C/NC
ALUMINUM	TEE	D,E,F	4,5,6	10,11,12	C/NC
ALUMINUM	I-BEAM	D,E,F	4,5,6	10,11,12	C/NC
ALUMINUM	PIPE	D,E,F	4,5,6	10,11,12	C/NC
ALUMINUM	SQUARE TUBE	D,E,F	4,5,6	10,11,12	C/NC

source: Study Team

The ultimate goal of changing a handling system can be related to reducing costs. This goal can be pursued by concentrating on one or more of the following objectives suggested by The Material Handling Institute^{7, 4} [12]

⁴Refer to possible code designations for the various strengths of shapes.

⁵Refer to possible code designations for various lengths of shapes.

⁶Refer to possible code designations for various weights per lineal foot of shapes.

⁷Numbers in brackets designate references at the end of this report.

TABLE II-3
GOALS OF MATERIAL HANDLING

1. **Reduced Costs:** Handling costs are reduced by eliminating unnecessary or repetitive handling, and by integrating handling steps with material flow through the shipyard.

2. **Reduced Labor:** Good handling practices will avoid strenuous manual effort and will usually reduce labor overhead.

3. **Increased Safety:** Reduced strenuous labor and unsafe manual tasks increase safety, mechanized systems equipped with safety interlocks reduce hazards significantly, and safety is enhanced when activities are performed in an organized, planned manner.

4. **Increased Capacity:** This objective can be met by increasing efficiency and using available space for work and storage, promoting effective inventory control, and increasing throughput with mechanized equipment.

5. **Reduced Waste:** Better in-process handling will improve product quality, reduce scrap, and minimize damage. Efficient handling also reduces waste by improving inventory control.

6. **Improved Service:** Better handling methods help service "downline" customers more efficiently, ensuring that their supplies arrive when needed, and with a minimum of damage.

7. **Higher Productivity:** Effective handling increases employee productivity, improves machine utilization, and helps create a more competitive position.

source: Material Handling Institute [12]

The handling problem definition requires that all constraints imposed on the handling system be determined. A list of the major constraints are shown in Table II-4:

Table II-4
MAJOR CONSTRAINTS

1. **Managerial:** Managerial constraints may be financial budgets based on a certain payback period, deadlines for proposals or getting a new system "on-stream," or unwritten philosophical constraints based on conservatism or boldness involved in other management decisions.
2. **Work Force Characteristics:** Worker characteristics that bind (or open the bounds of) a project are motivation levels, skill levels, and union cooperation.
3. **Material:** Potential material constraints are the weight, size and shape of the various items, the overall volume of material the system is going to handle, and special characteristics (such as those listed in Table II-1 and Table II-2). Positive attributes of the subject materials are that they are generally self supporting and rugged and do not require a lot of protection.
4. **Available Space:** The amount of space available may be an asset or a liability, but space usually limits choices relative to the type of storage and the movement methods utilized.
5. **Building Characteristics:** Building constraints include size, location of utilities, columns, obstructions, age, and openings.
6. **Equipment Characteristics:** Initial costs, capabilities, emissions, useful life, and maintenance are some constraints to consider.

source: Material Handling Institute [12]

A sample economic analysis, contained in Section VIII, gives some typical variations resulting from the introduction of constraints.

The expected results are to produce a concise picture of all applicable aspects of the problem. Operational capabilities should be defined. The previously mentioned items of problem definition should be condensed into a document summarizing the results and findings of the study to that point.

Preliminary findings may indicate that there is no real handling problem, and further analysis is not needed. A shipyard that has an efficient handling system may not perceive a problem. However, with the potential savings at stake, and the fact that handling the materials adds no value to the final product, it behooves the investigator to perform a basic analysis to prove the system sound.

The last part of problem definition is to develop a form by which to analyze the problem and to provide a solution. A rough form for analysis is recommended because, as the problem is studied to greater detail and solutions appear, the form of the analysis may change.

In this project the investigators studied pipe and shapes handling problems from the perspective of applying the solutions to a variety of shipyards using a variety of materials. The case study, in the appendix, narrows that perspective to give specific examples.

The method of analysis was to:

- 1. analyze movement and storage methods from the material handling perspective;*
- 2. present a form for analyzing a shipyard for material handling, including particular items that need consideration for handling pipe and shapes; and*
- 3. present sample analyses to support the methods discussed.*

III. REVIEW OF OTHER STUDIES AND THE LITERATURE

This section gives a generalized review of literature and related studies funded by earlier National Shipbuilding Research Program (NSRP) projects, and other related material handling literature. The reference is found in the reference section at the end of this report.

A material handling equipment study [13] performed in 1973 at Ingalls Shipbuilding relates mainly to large load transporters, such as 500-ton module lifts with airlift transporters. However a multipallet transporter was evaluated. This machine could lift and load itself with a rotatable fork lift mast, and carry three (up to six lightly loaded) pallets at up to 30 mph. The concept is interesting, but few, if any, are in use today.

Basic considerations for an automated pipe shop were described in the paper "Increase of Productivity by Automated Prefabrication of Pipe Spools." [32] A relatively general paper, it gives some basic, but important, guidance for material handling.

The paper titled "Automation of Design and Production of Piping Systems" [4] deals mainly with pipe system designs, but has some useful guidance for handling. The authors suggest including information on pipe storage locations on the working drawings to facilitate retrieval. The system stores a one-week supply of material in an automated retrieval system. Material is retrieved and placed into the automated pipe shop system as needed.

An advanced pipe technology study was conducted in 1976-77 [1, 2] which concentrated on pipe system design and specific fabrication items. General comments of relevance were that shops evolved by necessity and would be difficult to change; "conventional" pipe skids and pallets were common; material was handled by shipway cranes; and vendor supplies were unreliable. Specific highlights for material handling were:

- 1. use of a special steel pallet provided with lifting lugs and fork skids, and shaped to hold spools without strapping or the instability associated with flat pallets;*
- 2. two-inch and smaller pipe and tube were assembled on-board ships under construction in many shipyards (recall this is a 1977 report);*

3. one yard bent larger diameters of CU-NI pipe in the steel pipe shop then moved it to the copper shop for processing; and

4. one yard was noted as having a very large outside storage area for raw material and finished spools.

The report contains descriptions of the pipe shops in most of the active yards. Insufficient storage space for raw material and finished spools was noted as a common problem. Unfortunately, a final report was never issued and many details are missing.

A "Feasibility Study of Semi-Automatic Pipe Handling System and Fabrication Facility" [7] was performed at Avondale Shipyard in 1978. The study addressed many aspects of pipe handling but focused mainly on pipe shop machinery (such as benders and flange welders). Particularly interesting to this study were specific recommendations for handling pipe, summarized below:

1. a dedicated rack storage and locator system should be planned for pipe sizes 1 1/2-inch to 24-inch, with adequate provisions for loading, unloading and selection;

2. have sort and feed capability at the storage rack so the operator can automatically select and direct pipe from the rack and send it to a work station;

3. have a means for scrap to be conveyed out of the shop;

4. store finished spools before assembly in a palletized fashion in the order needed for assembly; and

5. handling and transportation means should be provided to move the fabricated pipe to the assembly site.

The report further recommends using a dedicated computer system to keep track of all the processes so that potential process savings will not be reduced by the costs of unproductive engineering and management time. Projected savings for material handling alone were 68 percent. Applicable parts of this study will be directly referenced in the body of this report.

The follow-on study to this report was the implementation of the feasibility study, [27] again mainly dealing with the semi-automated manufacturing of pipe spools, where a number of interesting facets of pipe manufacturing are stated:

- 1. roughly 25 percent of the total hull cost of a ship (in this case a LASH freighter) is related to fabricated piping;*
- 2. all the hardware for pipe shops is readily available, but was not installed as a total system in any of the shipyards visited in Phase I of the study, including yards in Japan and Germany (where much of the equipment is manufactured);*
- 3. work stations all have reserve areas for in-process storage; and*
- 4. the infeed rack capacity is designed for a two-week supply (a detailed inventory of this loading was provided).*

A report dealing with special structural shapes [28] was interesting in its analysis of economics of alternative structural shape usage, but did not address any aspects of material handling.

A series of MOST⁸ work management manuals prepared by the NSRP [14, 18, 15, 16, 17] provides little useful information for material handling. However, these manuals do give some reasonable guides to the incremental steps used in the production areas and from them one can infer the required material handling evolutions required to feed the production system.

The guide, "Basics of Material Handling," [12] and the follow-on guide "Advanced Material Handling" [11] are publications from the Material Handling Institute, a national trade association. They are excellent primers on the generic framework from which most all material handling problems can be addressed.

A computer software system was developed in 1980 as a joint project with Avondale and IBM [23] to manage the pipe manufacturing evolutions in a shipyard from system design to material ordering to pallet delivery at the outfitting stage of construction. Although it did not specifically address material handling, it certainly did address material control, and would be useful to an organization that had its manufacturing processes under

control and wished to streamline its material handling procedures. The same management systems can be used for shapes as well as pipes. This philosophy has been modernized, developed and, refined for use in modern computer systems and will form the basis of the "ideal" pipe and shapes handling system.

A beam line feasibility study [26] was done at Avondale in 1981 to look at automating the processing of manufacturing steel beams. Recommended handling specifics were use of:

- 1. an automatic feed system to feed beams into the processing area;*
- 2. an automatic conveying system is to move work between work stations;*
- 3. conveyors and transfer tables are used to move beams from side to side and at different angles for the line; and*
- 4. the ability to load short cut-off lengths onto a pallet wagon and transport to a pallet transfer area.*

The report does not mention raw storage and handling or long length kitting or palletizing. The arrangement of the central processing part of the facility is nicely described.

The NSRP study "Pipe Piece Family Manufacturing" (PPFM) [21] addresses the production philosophy used for pipe shops and is one of the benchmark references in that regard. However, it does not get directly into material handling problems. PPFM does set an important framework from which to prioritize material handling decisions to feed a well organized pipe shop. It states that:

". . . successful PPFM is logical classification and control of material. A warehouse organization dedicated to pipe shop methods is mandatory. . ."

The report encourages purchase of material by the classification scheme of "stock," "allocated stock" or "allocated" depending on whether the pipe is a standard consumable (stock), a specialized consumable (allocated stock) or special order (allocated) item. Applicable suggestions from the report were:

- 1. in planning for modernization of a pipe shop, each aspect of the system should be considered, along with its impact on other parts of the system;*
- 2. pipe-shop work flow should be in a single direction;*
- 3. in-process storage should be capable of 1/2 to 1 day capacity, and not consume too much floor space;*
- 4. space and handling facilities for stock pipe should anticipate one week operation. However, large diameter pipe, which requires excessive space, should be limited to 2 to 3 days stock, depending on anticipated volume; and*
- 5. a special facility should exist for any special work, such as repair or last minute changes, that would disrupt the regular work flow.*

An NSRP report issued in 1985 on material management [22] gives an in-depth look at all aspects of how material for ships is ordered, procured, stored and eventually used. The thrust of the report is to reduce material financing and warehousing costs by establishing better relationships with the supplier base. Material costs for shipbuilders with efficient processes (so labor costs are already minimized) account for 60 - 70 percent of the cost of a vessel. Related procurement, financing, and handling costs are the target for further cost reductions. The lowest bid for a particular purchase may not be the lowest overall cost when warehouse, handling, and inventory costs are added. Use of the ideas in this report would likely reduce the material handling and storage requirement and thus make it easier to streamline the remaining handling requirements.

A pipe movement and storage study [20] done by Avondale in 1986 is a natural progression from the earlier reports [7, 27] done by Avondale on the automated pipe manufacturing facility. Once the manufacturing processes, as a larger part of the whole pipe production process, were streamlined, Avondale examined improving efficiencies in the material flow ahead of the shop. Key recommendations from this study were:

- 1. large raw material savings could be realized by ordering double random lengths (DRL) of pipe for diameters over 2" then setting up a cutting facility at the outside storage yard;*
- 2. the outside storage yard should be a dedicated facility with dedicated personnel and equipment;*
- 3. A-106 pipe should be used where a mix of A-106 and A-53 pipe is specified to reduce the number of pieces in stock;*
- 4. specify delivery by flat bed trailer in bundles (for less than 2") or strip loaded; and*
- 5. order pipe with plain ends.*

The report deals primarily with ordering and outside storage and does not address racks or innovative handling methods. The handling parts of the report are generalized with the following reservations:

- 1. borrowed equipment (from other yard activities) may not be available when needed;*
- 2. certain pieces of handling equipment may not be able to manage DRL joints or unload gondola rail cars;*
- 3. storage racks limit the number of handling options; and*
- 4. storage at the receiving end of the pipe shop would be ideal; but space may be limited so storage would be scattered.*

An extensive survey was done by Avondale in 1985 [24] which looked at all aspects of light material movement and storage. The various types of equipment are described, as are many aspects of material management and control.

Kolodziejczak [10] gives an overview of the many considerations used to develop shipboard piping systems. The scope of piping systems manufacturing for various ship types is described, along with shop operations and design problems and the design/manufacturing interface. Group Technology and other producibility aspects of efficient manufacturing are addressed for piping systems. A comprehensive identification code is proposed to describe all applicable attributes of piping system design. The proposed code is used to direct a hypothetical production routing through a shop. A good historical summary of world, U. S. commercial and U. S. combatant shipbuilding technology is also provided.

Bruce [5] looks at shipyard material handling in support of the efficient manufacturing buzzwords of "group technology," "just-in-time manufacturing" (and material supply), and "flexible manufacturing systems." The axiom heard in many areas of shipbuilding that material handling adds no value to the product, but can contribute significantly to the cost of producing the product, is again presented.

Saginaw [25] describes the advances made at National Steel and Shipbuilding Company during the implementation of advanced production technology pipe shop improvements. Internal pipe shop arrangements and processes are the primary subjects addressed, but a major area is the support of the outfitting trades downstream of the shop.

Huber [9] relates to a generic philosophy of material handling calling it "flow." Material handling is often "taken for granted" but should be a primary consideration for cost reduction in any manufacturing entity. Use of automatic guided vehicles (AGV) is looked at not only for movement, but for use as in-process work stations and temporary storage. While not directly applicable to this study, it provides an interesting insight into current thinking on material handling.

The offshore oil industry has challenges similar to shipbuilding for handling pipe. Walstad and Crawford [31] have taken a detailed look at the expenses associated with mishandling expensive but fragile, high-strength drill pipe. Much of the paper deals with protecting threaded ends, corrosion protection in storage, and running the pipe at the well site. The importance of proper handling is emphasized.

A recently published study introduces Phase I of "Simulation Models for Development of Optimal Material Handling." [29] Phase I sets the framework by which a shipyard can evaluate its material handling evolutions, and optimize the whole system for least cost. The proposed

system requires the many parts of the material handling infrastructure to be recorded and entered into a comprehensive data base. Included must be material handling equipment and capacities, yard layout, types of surfaces, personnel and skill levels required for each handling evolution, and the properties of the material to be handled.

Sullivan [30] discusses "Trends in Material Handling" and keys on the issue of getting away from the all-out, hi-tech methods, such as huge automated storage and retrieval systems (AS/RS), and into refining the management of smaller or manual systems.

IV. PRINCIPLES OF MATERIAL HANDLING

The objective of this section is to define several principles that can be applied to any material handling situation. The primary sources used in the development of these principles were Eastman [28] and Kulweic [12, 11]. These principles should be considered as guidelines from which to analyze a planned or existing handling system. The principles are as summarized in Table IV-1 and explained more fully below.

ORIENTATION

The orientation principle is vital to any industrial engineering problem-solving evolution. As described in section III, this includes problem definition and a thorough analysis of the existing situation, which should be done with the other principles kept in mind.

PLANNING

The handling problem should be optimized in the planning process. Handling should also be balanced against the efficiencies of other parts of the yard. Just as islands of automation in a production process are not very useful, an island of overly efficient material handling is not useful if not balanced against the operations around it. The planning principle is used in the Design Analysis section, Section VIII.

INTEGRATION

The integration of the handling system into a coordinated system that includes all aspects of the problem will produce a more efficient overall system. Material flow should be in one direction and along the shortest path. Any alternates are likely to increase costs and detract from an efficient system.

FLOW OPTIMIZATION

Flow optimization can play a crucial role in the productivity of a production line where "raw" material enters at one end, is added to other parts along a path, and an interim or finished product comes out the other. Crossed paths, backtracking, and other deviations from the main path are avoided. While not as obvious to the gross handling requirements of the raw material alone, the principle of flow optimization should be considered when redesigning a handling system.

Table VI-1

THE 20 PRINCIPLES OF MATERIAL HANDLING

1. **Orientation**. Study the system and define problems.
2. **Planning**. Plan all material handling and storage activities to obtain maximum overall operating efficiency.
3. **Systems Integration**. Integrate as many handling activities as is practical into a coordinated system of operations, include vendor, receiving, storage, production, inspection, packaging, warehousing, shipping, transportation, and customer.
4. **Flow Optimization**. Provide an operation sequence and equipment layout optimizing material flow.
5. **Simplification**. Simplify handling by reducing or eliminating unnecessary movements and/or equipment.
6. **Gravity**. Utilize gravity to move material wherever practical.
7. **Space Utilization**. Make optimum utilization of building cube.
8. **Unit Size**. Increase the quantity, size, or weight of unit loads or flow rates.
9. **Mechanization**. Mechanize handling operations.
10. **Automation**. Provide automation to include production, handling, and storage functions.
11. **Equipment Selection**. In selecting handling equipment consider all aspects of the material handled - the movement and the method to be used.
12. **Standardization**. Standardize handling methods as well as types and sizes of handling equipment.
13. **Adaptability**. Use methods and equipment that can best perform a variety of tasks and applications where special purpose equipment is not justified.
14. **Energy**. Evaluate and optimise energy utilization of handling equipment and manpower.
15. **Maintenance**. Plan for preventive maintenance and scheduled repairs of all handling equipment.
16. **Obsolescence**. Replace obsolete handling methods and equipment when more efficient methods or equipment will improve operations.
17. **Control**. Use material handling activities to improve control of production, inventory and order handling.
18. **Capacity**. Use handling equipment to help achieve desired production capacity.
19. **Performance**. Determine effectiveness of handling performance in terms of expense per unit handled.
20. **Safety**. Provide suitable methods and equipment for safe handling.

source: Study Team

SIMPLIFICATION

Simplification is a principle that becomes self evident when a detailed study of existing material handling methods is done. A material handling evolution is best studied by dividing each handling task into the incremental steps that are required to be completed. For example, a simple "lift" step involves locating the material in storage, positioning the lift truck or other device, lifting the objects, possibly bailing the objects, backing the truck out of the storage location, and lowering the load for transport. Each one of these steps is deserving of scrutiny to look for possible system savings.

Automation is not always required. For example, use of an automated storage and retrieval system (AS/RS) can be beneficial for a distributor that is constantly handling various materials, but is likely to be too complicated and is not justified for lesser handling requirements.

GRAVITY

Gravity seems to be a simple principle to use, but it is still an important one to consider. Gravity is frequently used for pipe because of the ease of rolling the objects. Care must be taken to keep pipe from rolling too fast, or the pipe (especially copper or copper-nickle pipe) or handling equipment may be damaged, or handling personnel may be placed at risk.

SPACE UTILIZATION

Space utilization is probably the most common rule for effective storage, but is frequently ignored in favor of seemingly less expensive "spread out" storage. Space utilization is simply the most effective use of the "building cube." A storage building with high ceilings that uses floor or low-capacity racks is wasting the space up to the ceiling. Outside storage can improve by keeping the storage system neat, concise and orderly. This eliminates excess movement and distance for handling machinery, thus cutting costs.

UNIT SIZE

Unit size is a difficult concept to quantify for pipe and shapes. For simple material handling, a unit may be a standard pallet, a cardboard box, or a ton of bulk material. For pipe and shapes, the unit must be defined based on the equipment and space available. Application of this principle may also require an analysis of the purchasing function. Therefore, it would seem that a material handling system that could handle the occasional

60-foot long, wide flange I-beam, or the 46-foot (longest of double random length) pipe would be the optimum. Other considerations that may be addressed are the frequency of moving these largest pieces, the ability to handle smaller loads, and the flexibility of the machinery for other applications.

ADAPTABILITY

Few material handling arrangements can be dedicated to the same task for an extended period. Most systems should be designed with a flexible capability to allow changes in the system without complete system redesign. For example, a shipyard that optimized its handling capability for large diameter steel pipe for a run of standard petroleum product tankers would need to redesign its system to accommodate a naval vessel with large amounts of copper-nickle pipe, or a chemical tanker with large amounts of stainless steel piping.

AUTOMATION

Automation is a principle that is often over emphasized. Few shipyards can justify the expense of an AS/RS for any part of their material handling requirements. Reasonably automated tasks can be as simple as the use of bar coding for material identification and inventory control, or automated feed from the in-process pipe storage system.

EQUIPMENT SELECTION

Equipment selection is more of a caution than a principle. The warning is to consider all aspects of the material being moved and stored and choose the equipment that best satisfies most of the handling requirements. For example, an all-terrain, high-lift fork truck may have the weight capacity, rough ground capability, and the ability to load high racks. But if the fork truck has narrow forks or can not accommodate a clamping device, this truck will be unable to safely handle long objects across the forks.

MECHANIZATION

Mechanization can reduce labor costs. Manual handling is generally slower, prone to error, possibly dangerous, and more costly than mechanized handling. Pipe and shapes discussed in this study are

generally too large for manual handling alone, but guiding and sorting are some manual operations that can be eliminated by proper use of mechanical handling devices.

STANDARDIZATION

The SNAME Ship Production Committee has a panel (SP-6) to study the standardization of items and procedures used in actual ship construction. Significant savings are realized when standards are implemented in ship construction and material handling. For example, if gantry cranes and specialized pallets are the prevalent system used in the area, it may be wise to adapt this system for other handling requirements.

ENERGY

Overall energy usage in many shipyards is so large that looking at energy efficiency in a single segment of a material handling system seems to be a trivial matter. However, energy usage can be a significant factor used for comparing alternatives. Electric vehicles are more energy efficient for space limited applications, but are not as flexible for operations at a variety of dispersed locations. Internal combustion powered vehicles are more powerful and flexible, but waste energy while idling. Energy is but another important principle to consider when weighing alternatives.

MAINTENANCE

Maintenance should also be considered when evaluating alternatives for handling equipment selection. Most handling equipment has maintenance requirements, including repairs and component replacements. Electric fork lifts require battery replacement, combustion engine trucks require scheduled maintenance, occasional rebuilds and possibly replacements. Storage buildings, outside storage bunkers and bar code readers should all have maintenance and repair planned into their life costs.

OBSOLESCENCE

The useful life of equipment should be considered during the planning stages so that obsolescence doesn't overtake the system. A handling system whose components are designed for twenty years may be overly expensive when technology may make it obsolete in ten. For example, a decision to use internal combustion powered vehicles over

electric vehicles, for range or continuous endurance advantages, and then plan for a twenty year life may be ill advised with the rapidly developing capacity of heavy duty batteries. Planning for obsolescence may be a questionable proposition, but a necessary step.

CONTROL

Control is a principle that can be applied in two ways. One wants to maintain as much control of an operating handling system as possible. Control can be illustrated by a comparison of two material handling scenarios. In one, a machine operator is given a list of pipes that need to be moved from long term storage to a pipe shop supply silo in a certain time period but in no particular order. The operator is given the responsibility to decide what machine to use, when to get which pipes, where to find the material in the yard, and so on. In a controlled situation, the operator is directed to move specified pipes from a specific location with the most efficient machine at a predetermined time and order.

The other application of the control principle is to use the moving and storing system to improve control of inventory, order handling and production. The material handlers can be given inventory control responsibility. If the beginning quantity of any item is known, and the handling people are the only ones adding or subtracting from the stock (assuming a reliable system) there is no need for a separate inventory system. Quality material handling can help control production by ensuring that the proper materials are in the proper place at the proper time and condition. Production is the "customer" of the handling department and should be supplied with quality service.

A similar philosophy is recommended for production process control. If the process is in control and producing quality parts or assemblies, there is no need for post production inspection or "quality control." The process being in control is the quality control. The same can be said for a handling system.

CAPACITY

Handling equipment and systems should be planned to satisfy production capacity. Otherwise, the handling system will be overdesigned and not very cost effective. An alternative, which could be the exception to prove the rule, is that all gross material handling can be done in one shift

to supply a production facility, which is more efficient operating around the clock. The production shops that use the pipe and shapes subject to this study usually have custody of the raw material for a longer period than the handling department that feeds the shop. Thus, the shops can usually be supplied in relatively short order. Furthermore, single shift labor is usually less expensive than a multi-shift force.

PERFORMANCE

The performance of the material handling system is its measure of efficiency. Expense per unit load is the measure of merit utilized in judging performance for most systems. Alternative measures would have to be considered for systems that handle sensitive or fragile material, or are optimized for some other priority.

SAFETY

It should be understood that consideration of safety is constantly a concern for planning and implementing a material handling system. While it is easy for planners to get caught up in the process of planning for efficiency and cost effectiveness, they must be aware of the potential expenses associated with personnel injuries. These personnel injury expenses may be significantly larger than the initial investment cost associated with the implementation of a "safer" system.

V. UNIT LOAD DEFINITION

A unit load is a common size and weight of material in a particular handling system that groups a number of smaller items into a single unit that can be easily handled. For bulk material such as coal or iron ore, the unit is usually a ton. For many warehousing operations, the pallet is the common unit. Pallets are handy objects for unitizing because racks, fork trucks, conveyers and many other parts of the handling industry have specialized in handling pallets. For pipe and shapes handling, the common 4' by 4' pallet will not manage 40' or 60' material. Larger specialized pallets have been developed to handle these materials in intermediate processing stages and will be described in detail in another section. Unit load handling "promotes faster movement of goods, permits personnel to handle larger loads, reduces loading and unloading times, reduces inventory and space requirements, and cuts costs." [12]

The unit load must take into account the largest pieces of material to be received in economic order quantities and the normal size pieces that can be handled by common handling, storing and processing equipment. Some common raw material sizes were shown in Tables II-1 and II-2

The other factor that must be considered for unit load definition is the type, capacity and availability of existing handling equipment. In a large shipyard, with large volumes of pipe and shapes throughput, a detailed analysis is likely to show that purchase of a specialized piece of equipment to handle the largest unit load is justified. In smaller yards with less volume, a combination of limiting raw material size and adapting existing equipment is a likely handling choice. Examples of unit load development for different materials are presented, and a unit load is developed in the case study in Section VIII.

Basic attributes of a unit load designation are:

1. *raw material length,*
2. *dimensions,*
3. *weight (including unit weight or weight per foot), and*
4. *material type (magnetic, fragile, etc.).*

After the materials are broken down into unit loads, the whole handling procedure can be analyzed by the number of unit loads moved and the time required to move each unit load. This is the basis from which many handling evolutions can be studied. Some examples are presented for unit load development, then a simple unit load code is proposed.

A typical unit load development example is for a large yard handling large steel I-beams. Wide-flange I-beams W-type 36X300 in 60 foot lengths are unloaded from a rail car. Each one weighs 18,000 pounds, or nine tons. For a 25-ton crane with a 1,000-pound spreader bar, a unit load is two beams. When the beams are deflanged to make T-sections, 5,700 pounds of flange are removed. Now the unit load includes four T-sections. In this example, the unit load for this stage of handling is totally weight dependent.

Another example of unit load development is for a double random length (DRL) load of 8-inch schedule-80 pipe, each pipe weighing 43.4 pounds/foot. The available handling equipment is a 15-ton lifter-loader with steadying clamps, so length and stability are not a problem. Double random length joints have an average length of 42 feet, so each joint weighs nearly 0.91 tons, and 16 make the weight limit on the loader. However, the loader forks are only four feet long, and pipe is only practically carried one level at a time, so the unit load is limited to five pipes at a time by volume.

Therefore, a proposed unit load designation or classification system must also contain enough information to relate to the handling equipment available. A likely form for such a system is:

Z-AA-BB-CC-DD.D-EE whereas:
Z->E = Equipment, S = Shape, and P = Pipe,
AA = length in feet,
BB = height in inches,
CC = width in inches,
DD.D = total weight in tons, and
EE = special handling notes.

The Z is used to designate whether the code is the limitation of the handling equipment, or the handling attributes for shapes or pipe. The A-D variables are numbers designating the physical limitations of the handling equipment. The EE is an alpha-numeric code used to designate

special handling capabilities, such as padded forks or nylon slings for sensitive materials. For the I-beam example above, where the crane was weight limited, the equipment and material unit load codes would read:

Crane code E-XX-XX-XX-25.0-C1
Shape code S- 60 - 37 -17- 09.0-XX

Specifying for the crane that:

- 1. any size of pipe or shape could be handled,*
- 2. the maximum weight capacity is 25 tons, and*
- 3. the C1 indicates that nylon slings are available for soft materials such as copper pipe.*

The equipment code for this example shows that the crane can handle any basic size of material as long as the weight does not exceed 25 tons. The unit load is determined by dividing the weight capacity by the material piece weight to find that the unit load is two pieces.

For the loader with the pipe example, the equipment and material unit load codes would read:

Loader code: E-44.0-24.0-48.0-15.0-PD
Pipe code: P-42.0-08.5-08.5-0.91-XX

Specifying for the lifter loader that:

- 1. The longest length to be handled is 44 feet (limited by sway stability)*
- 2. Depth of the clamps limits height to 24 inches,*
- 3. Fork width limits material width to 48 inches,*
- 4. Maximum load weight is 15 tons, and*
- 5. PD could mean padded forks are available.*

Comparing the loader code to the pipe code below it shows that the limiting factor is fork width that makes the unit load five pipe pieces.

A unit load code for the material handling attributes of pipe and shapes could be related to the classification system used for pipe and shapes production. If a classification system for production is not used in a shipyard, a much simpler system should be considered for just the handling aspects of the materials.

Kolodziejczak [16] proposes a classification code for the pipe fabrication processes. His first attempt at code development required a 24 digit numeric code to include all the applicable attributes for joining two pieces of pipe as shown in Table V-1.

**Table V-1
PROPOSED PIPE CLASSIFICATION CODE**

Digit	Attribute
1	Material
2	Wall thickness
3	Number of fittings
4	First pipe: diameter
5	Length
6	Number of cuts
7	Number of bends
8	Number of joints
9	Second pipe: diameter
10	Length
11	Number of cuts
12	Number of bends
13	Number of joints
14	Special assembly requirements (drill, thread, crane)
15	NDT requirements
16	Treatment
17	System (SWBS)
18	System (SWBS)
19	System (SWBS)
20	Ship
21	Ship
22	Unit
23	Unit
24	Unit

source: Kolodziejczak [10]

This code has information that is useful to handling, such as material type, diameter, and length, but does not include the original length of the raw material. However, this code was considered too cumbersome, and a simpler code was proposed that did not contain length or wall thickness. In actuality, there are probably as many classification codes as there are pipe shops. The point is to utilize a code for data that can facilitate improved handling.

If a code similar to Kolodziejczak's first code were in place at a shipyard, it could be used to drive the purchasing function for pipes or shapes. The useful entries could be drawn off to generate the bill of materials and a nesting function for initial processing. In addition, identification tags or bar codes could be generated from the same information and used for material identification at the receiving station.

The Avondale report [20] describes the savings from purchase of double random lengths (DRL) of raw pipe. Double random length joints range in length from 38 to 44 feet, with the average being 42 feet. The recommendation made was to have a processing area at the point of receipt to cut the pipe into roughly 21-foot uniform lengths and allow the odd ends as waste. With detail design information available at this stage of handling, a good nesting program can designate pipe cut lengths and identify the final piece or pieces that will be produced from that pipe, eliminating much of the waste. A similar process can be used for shapes. Data from this information can be used to establish unit load numbers and sizes to facilitate the handling process.

This scenario also assumes a fully controlled process. It assumes that detailed engineering information for each pipe or shape piece is available before purchase. However, this is seldom the case as confirmed in interviews conducted for this study with shipyard pipe shop managers. More often, material, especially long lead time material, is ordered after contract award but before detail design is initiated. The best expectation is that detail information is available before receipt of material, so that identification and initial processing can be done at that time.

VI. ANALYSIS OF MOVEMENT AND STORAGE METHODS

This section describes handling equipment that may be used for movement and storage of pipe and shapes. Much of the equipment is adapted from other handling tasks. No attempt has been made to describe every possible piece of handling equipment and its use relative to this study. Only general descriptions of equipment are included without a detailed study of price, purchasing or leasing options, specific capabilities or limitations.

For more detailed information on equipment, the associations and institutes listed in the appendices, along with their members, should be contacted. An extensive list of handling equipment manufacturers and suppliers is in reference [29]. Industrial registers, such as the Thomas Register, list these and other suppliers and distributors by area.

A. MOVEMENT

Most movement of pipe and shapes involve practical applications of existing equipment. The raw materials are received in 40-60 foot lengths and have a large polar moment of inertia. Movement and swing must be controlled to keep the materials from becoming a safety hazard or causing damage. Standard types of handling equipment are described below.

INDUSTRIAL TRUCK

Industrial trucks, also called fork lifts or fork trucks, are probably the most common piece of handling equipment used in a shipyard. Fork trucks are useful for handling pallets and similar consolidated loads, but limitations arise when used for handling pipe and shapes. Various sizes and capabilities are available. A listing of manufacturers in the Industrial Truck Association (ITA) is contained in the appendix.

The main problem that industrial trucks have with handling pipe and shapes is maintaining stability. Long objects are lifted and carried across the forks and across the direction of travel of the vehicle. The materials are subject to inertial loads as the vehicle is maneuvered. Sudden stops and turns can cause the loads to swing off the forks. Consequently, handling is slowed, worker safety is at risk, and material is often damaged. However, there are add-on bailing attachments that can clamp the load to prevent this problem, as shown in Figure VI-1. This particular attachment is manufactured by CBI Clackamas in Portland, Oregon and is available through industrial truck dealers. It requires an auxiliary hydraulic port on the fork truck.

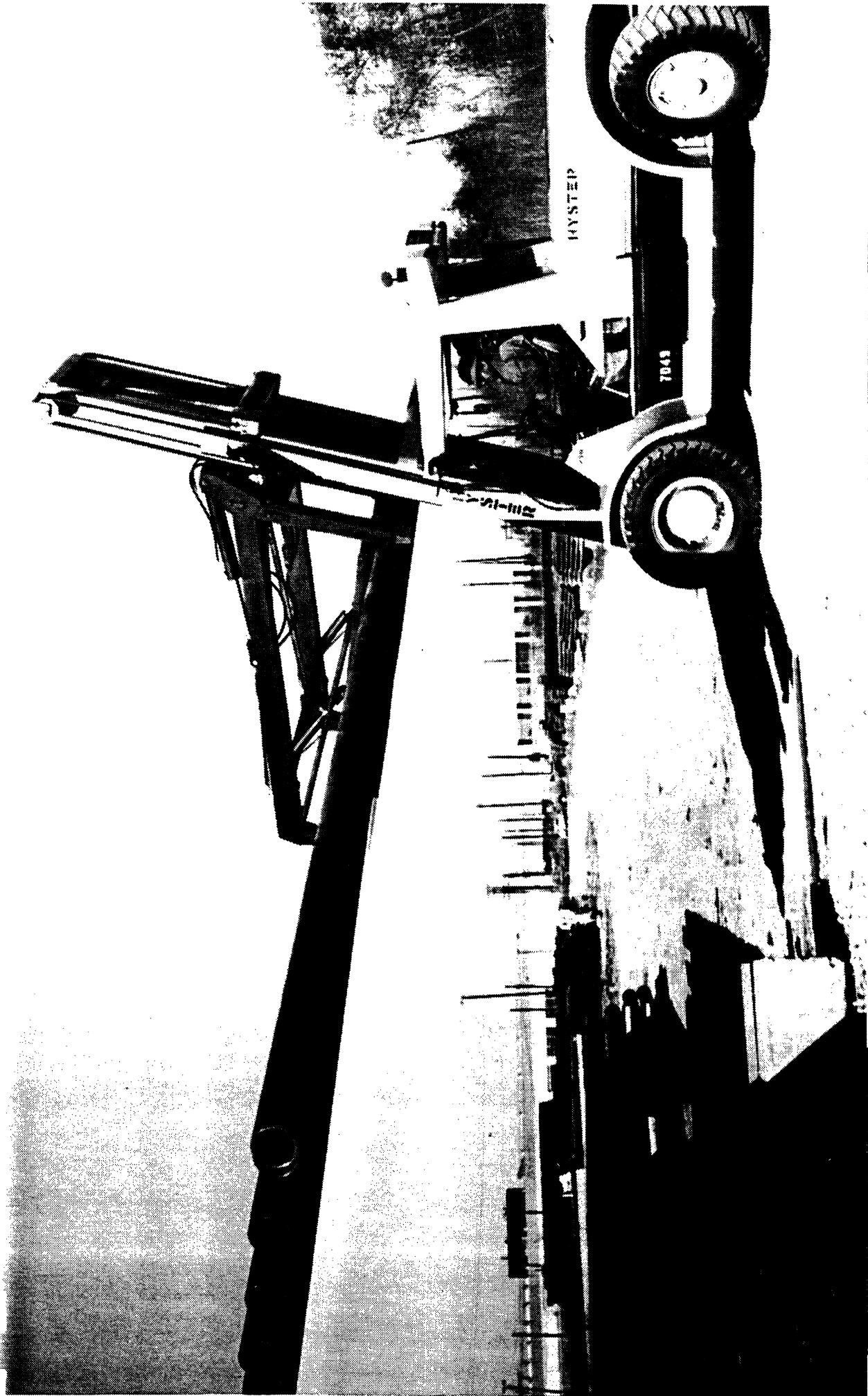

source: CBI Clackanas

Figure VI-1
PIPE BAILER CLAMP

SIDE LOADER FORK TRUCKS

A special class of fork trucks called "side loaders," often referred to as narrow aisle lift trucks, are particularly applicable to pipe and shapes handling. The load is carried along the side of the vehicle with the long axis along the direction of travel. They are generally electric trucks used for high density inside storage as shown in Figure VI-2.



source: Rack Manufacturers Institute

Figure VI-2
SIDE LOADER FORK TRUCK BETWEEN CANTILEVER RACKS

LIFTER LOADER

A lifter loader is a variation of a front end loader used for earth moving or handling equipment use in the logging industry. Its advantage over a standard fork lift is rough terrain capability and the ability for forward reach. The rough terrain ability is an advantage in open storage areas with unprepared surfaces; it is a feature not found in standard fork trucks. The lifter loader also has a stronger drive train for towing mule trains or other trailers. Most of the available lifter loaders also have bailing attachments already built into the lift arm.

STRADDLE CARRIER

A straddle carrier is a specialized truck for lifting and carrying prepared loads below the body of the machine. Thus, loose pipe and shapes can not be handled or manipulated and must be palletized by another device before this machine can handle the material.

A straddle carrier's main advantage is its ability to drive over dense ground storage with just narrow isles between material required for wheel travel, as shown in Figure VI-3. Storage space is maximized but pallet load height is limited to half the machine's underbody clearance, typically 68 inches in smaller machines and 106 inches in the largest ones. With the load carried below the body, the operator rides in a safer location. Pipe and shapes can be carried along the the direction of travel of the machine but wide loads longer than the wheelbase will limit turning radius.

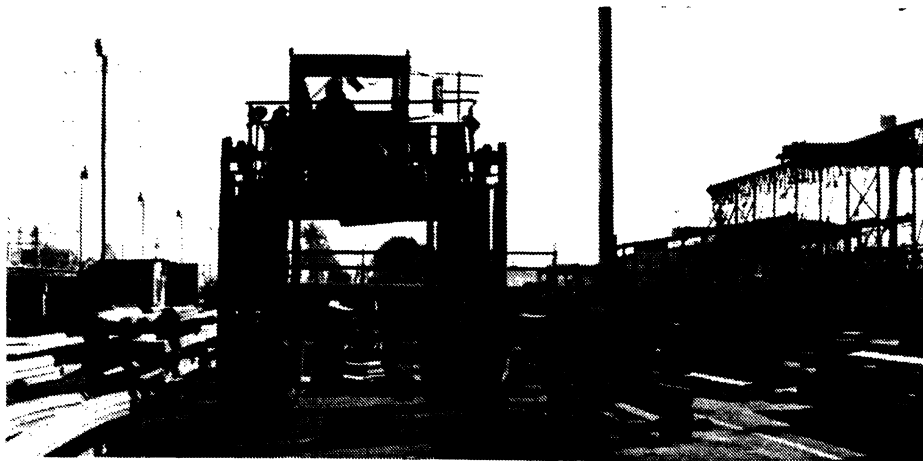

source: National Steel and Shipbuilding Company

Figure VI-3
STRADDLE CARRIER

General demand has been low for straddle carriers. The last new U.S.-built machines were being produced at the end of 1990, so only used and rebuilt machines will be available.

CRANE

Cranes are one of the most common types of material handling equipment utilized in a shipyard. The four main types of cranes are bridge cranes, jib cranes, gantry cranes, and mobile cranes.

Bridge cranes are common in panel lines, pipe shops, and machine shops. These cranes may also be used in open locations. Top-running bridge cranes are supported by horizontal beams which are supported by ground mounted columns. These cranes can have capacities as high as 800 tons and have a span as high as 130 feet. A bridge crane is shown in Figure. VI-4.

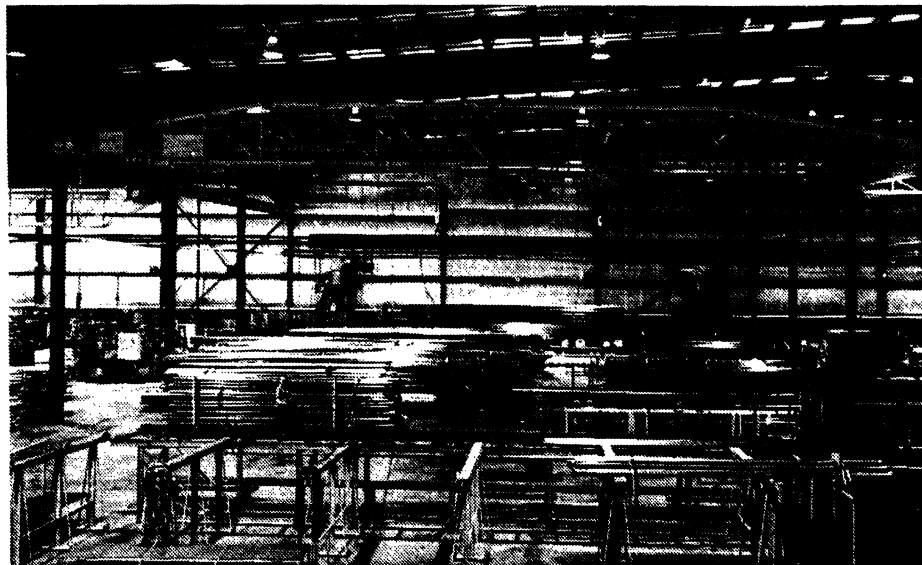

source: Loudon Products

Figure VI-4
BRIDGE CRANE

Gantry cranes are similar to bridge cranes, except that they are self supporting and travel in railways on the ground. The capacities and spans of gantry cranes are comparable to bridge cranes. An example of a gantry crane is shown in Figure VI-5.

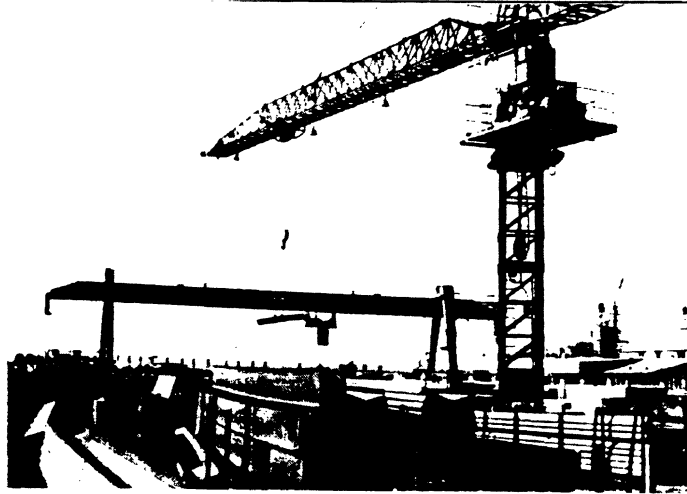

source: National Steel and Shipbuilding Company

Figure VI-5
GANTRY AND TOWER CRANE

Jib cranes are self supported structures that run on railways. They typically have the ability to rotate so that they can access open work areas. The lifting capacities of these cranes is typically less than maintaining gantry and bridge cranes. Common practice is to use more than one jib crane for heavy lifts. An example of a bridge crane is shown in the background of Figure VI-6.



source: National Steel and Shipbuilding Company

Figure VI-6
JIB CRANE, MULE TRAIN IN FOREGROUND

Mobile cranes come in many types and sizes. They may be low capacity wheeled vehicles, crawler-type vehicles, or floating cranes. The most common types of mobile cranes employed in a shipyard are wheeled vehicles for smaller lifts. An example of a mobile crane is shown in Figure VI-7.

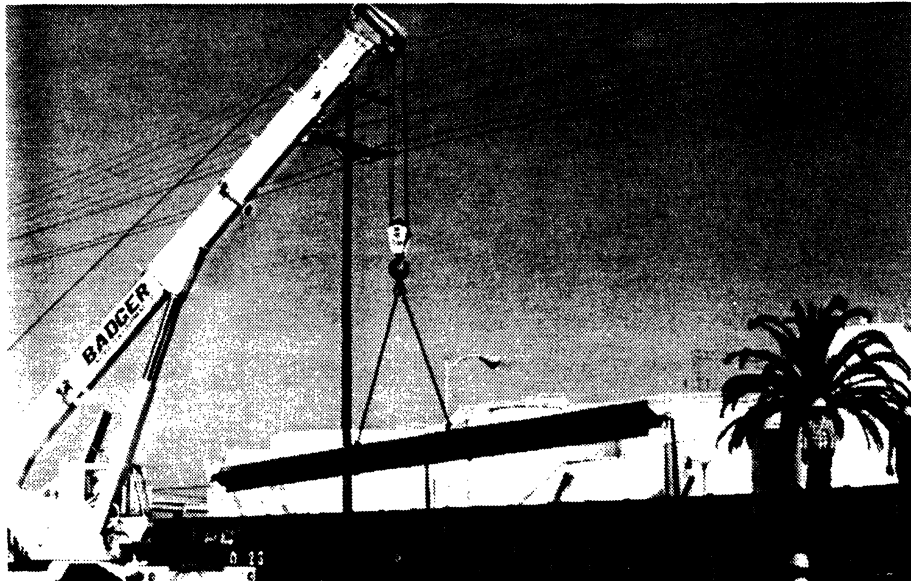

source: National Steel and Shipbuilding Company

Figure VI-7
MOBILE CRANE UNLOADING SHAPES WITH A CHAIN SLING

The many types of cranes used in shipyards are characterized by single hook lifting wires. The typical single hook allows long loads like pipe and shapes to rotate, to be imbalanced, and require a ground crew to attach loads. Gantry and bridge cranes are available with dual lifting cables that eliminate rotation of long loads.

The best arrangements for cranes include a dual cable and a lifting attachment to limit the involvement of riggers to attach each piece. Electromagnets are the most common attachments, but are obviously limited to steel pipe. Strength of the magnets can be varied to attach the desired number of pipes or shapes. Groups of gantry cranes with magnetic attachments on dual wires are common at pipe manufacturing facilities where large amounts of steel pipe are loaded into railroad gondola cars.

Specialized cranes are used by non-shipyard operations for high volume applications. Man-aboard stacker cranes are used for situations similar to those for narrow aisle side loader fork trucks. The advantage with these cranes is that the operator is above the load and floor space is

freed. Other variations add a rotating turret to allow more flexibility in manipulation of material.

LIFTING ATTACHMENTS

There are a number of other lifting attachments adaptable to or developed for pipe and shapes handling from cranes. Most of these devices fit the category of "under the hook lifting devices" and "overhead lifting attachments." The Hoist Manufacturers Association and the Crane Manufacturers Association of the Materials Handling Institute should be contacted for additional information on this equipment. Many of the manufacturers publish lifting instruction and safety guides. In addition, the American National Standards Institute (ANSI) has a safety standard titled "Below the Hook Lifting Devices," (ANSI/ASME B30.20-1985) covering the subject.

Some of the lifting attachments are listed in Table VI-1.

TRAILERS

Flat bed over the road trailers are the most common method for receiving pipe and shapes and are a useful piece of equipment for moving and storing the materials in the shipyard. Three types have been observed as particularly useful for pipe and shapes.

Regular flat bed trailers are readily available, and for a used trailer in suitable condition to carry loads at low speeds around a shipyard, should be relatively inexpensive. Used in conjunction with a dolly (instead of a separate tractor) and a fork lift or lifter loader capable of pulling it, the trailer becomes an efficient handling unit. A trailer with a dolly is shown in Figure VI-8

A low-boy trailer has the additional advantage of handling a greater load height, that gives a greater load carrying capacity for bulky low density materials such as larger diameter light schedule pipe. They also provide a lower platform requiring lower lift heights and giving operators a better view for material placement.

Another handling arrangement made possible with a low-boy trailer was seen at the US Steel works in South Chicago, Illinois, where wide flange I-beams are produced. The I-beams are produced in 60-foot lengths and loaded onto a pallet frame by an overhead crane. When the frame is loaded to capacity, a low-boy trailer with a hydraulic lift bed is backed under the frame, the frame is picked up and moved to a remote location.

Table VI-1
LIFTING ATTACHMENTS

1. **Lifting Beams or Spreader Bars.** These are common devices for spreading the lifting forces from a single hook to a double hook. Use of two wire slings to spread the load on a pipe or shape can be dangerous when the slings slide to the center of the load and cause the load to tip or sway. Adjustable spread hooks are available to level off-center loads.

2. **Pallet Lifters.** These devices convert a single hook crane to an overhead fork truck for lifting pallets and other items with fork type lifting openings.

3. **Lifting Tongs.** These are "scissor" type devices that can be used for a limited range of pipe diameters and rectangular cross section objects. The tongs must have clearance on both sides to grip the object. They can be doubled on a spreader bar to spread out the single point lift. However, standard tongs must be manually set and released.

4. **Pipe Grabs.** Pipe grabs are designed for specific pipe diameters. They are usually self opening, but require a manual release. As with the tongs, the grabs must have clearance on both sides to grab the object.

5. **Beam Clamps.** These are specialized heavy duty lifting tongs for wide flange I-beams. The weight of the clamp opens its tongs when lowered over the flange, but standard models must be manually released.

6. **Slings.** There are many standard types of slings such as wire rope, chain, wire mesh and nylon web with various types of hooks and links for attaching them to the crane hook. An interesting option to add to a wire rope sling for pipe and shapes handling is the Adjust-A-Leg® load leveling sling from the Caldwell Co., Rockford, IL. This attachment changes the lift center to match the load center of gravity.

7. **Motorized Hooks.** Motorized hook devices are available to control hook rotation and eliminate the need for riggers to tend the swing of long loads, a relatively unsafe practice.

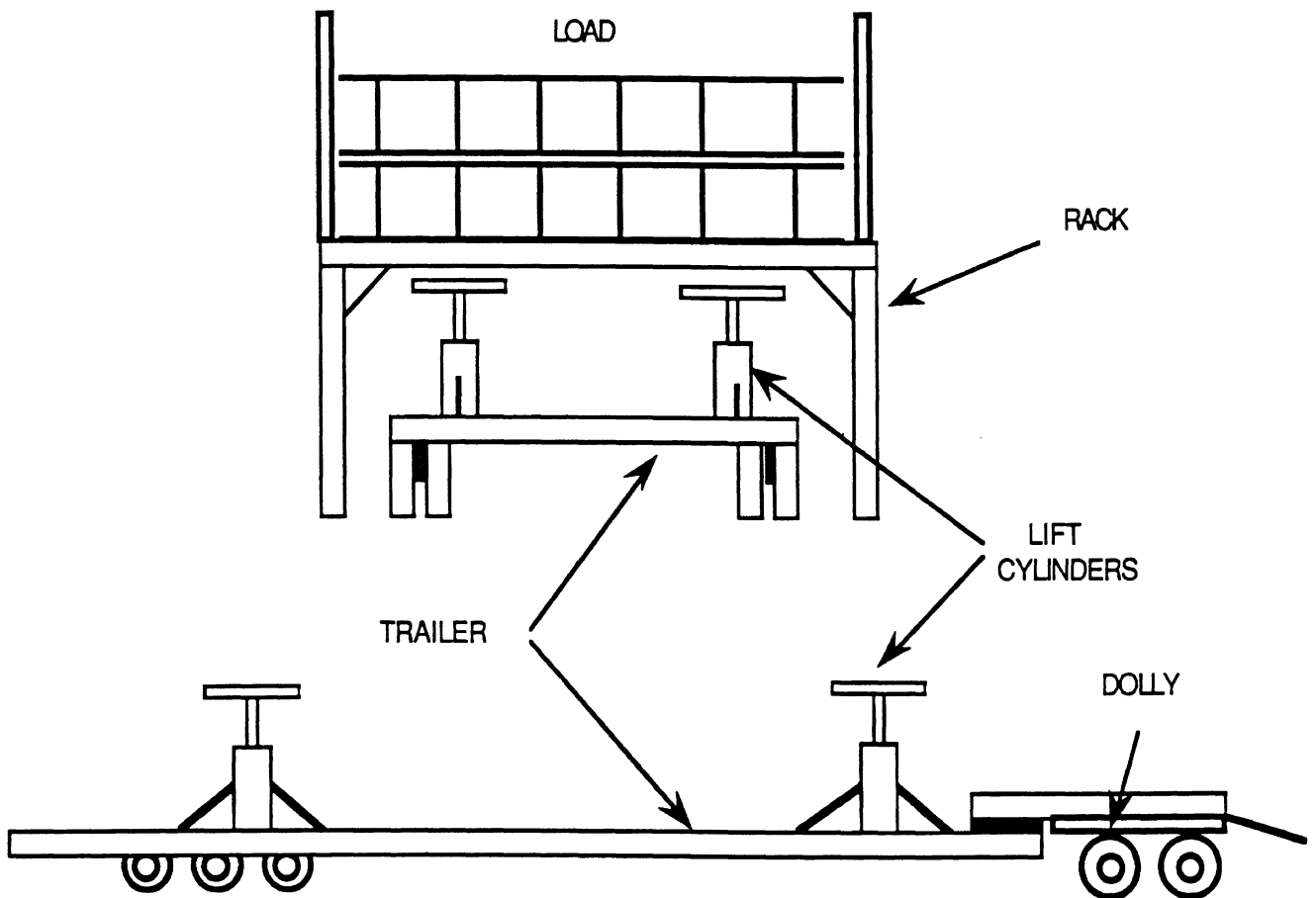

source: Study Team

Figure VI-8
LIFT TRAILER

In this case, the movement is about three miles to a processing facility. The basics of the arrangement are shown in Figure VI-8.

The other type of trailer arrangement useful for material handling in general and adaptable to pipe and shapes is referred to as a "mule train." A mule train is a combination of a fork truck or a lifter loader as the "mule," and a train of small trailers, usually handling palletized cargo. A mule train in use at NASSCO is shown in the foreground of Figure VI-6. This arrangement is suited to handling a variety of palletized material from one or many locations to a number of locations. Efficient utilization for pipe handling would be to retrieve a number of palletized outfit packages from a storage location and deliver them to various work stations where outfit work is being done.

The mule train arrangement is not well suited to raw material handling, where a standard long flat bed is more appropriate. In addition, the towing capacity of the mule may limit the total capacity of the train. The drive trains of most fork trucks and lifter loaders are rated to move the machine and its rated load. The maximum towing capacity should not be exceeded with the combined load on a mule train. Use of a fork truck larger than that necessary to load the trailers is one way to circumvent this problem. Another is to modify the mule with a stronger axle and brakes for towing.

CONVEYERS

Conveyers were investigated for this study but were not seen in use as a raw material handling device. Conveyers are used for intermediate and in-process handling for limited travel distances in shops. Nevertheless, use of conveyers for limited distance pipe and shapes raw material handling is conceivable, especially where space next to a shop for temporary storage is limited.

There are three types of conveyers applicable to pipe and shapes handling. Roller conveyers are the most common and are available tapered or flat, powered or free rolling. Tapered conveyers are best for handling pipe. They are tapered to the center to keep pipe from rolling off and can handle a range of diameters. Straight rollers can handle both materials, but require side rails to keep them in line. The number and spacing of free and powered rollers depends on the length of material being handled. For 20 foot and longer items, roller spacing could be 5 feet with powered rollers alternated with free rollers. Conveyers should use the gravity principle of material handling if the system can be arranged to take advantage of a slope. This would limit the number of powered rollers required and reduce the cost.

Overhead monorails with either continuous chain drives or self-powered hooks are considered conveyers but are more applicable to delivery of parts to work stations inside the shops than they are to movement of raw materials as cumbersome as pipe and shapes. The other handling device considered a conveyer is a floor mounted, tracked system for moving work containers, usually with a chain. Again, this is mostly a shop handling system not applicable to raw materials.

B. STORAGE

Efficient storage of pipe and shapes is dependent on several variables. Basic considerations for design of efficient storage systems are listed below:

- 1. maximum use of the building or facility "cube";*
- 2. effective use of time, labor and equipment;*
- 3. ready accessibility of all items;*
- 4. rapid easy movement of materials;*
- 5. positive item identification;*
- 6. protection of materials form damage and unauthorized appropriation; and*
- 7. neat and orderly appearance;*

Each of these guidelines should be reviewed when analyzing storage arrangements.

The ideal method of minimizing storage costs is to eliminate as much storage as possible. Eastman [6] states: "The ideal storage (system) is (to have) none at all". Just-in-time (JIT) delivery of material would eliminate most of gross raw material storage requirements. However, the economics of large and economic order quantities, and the need to level load the production shops for effective use of production labor, outweigh the advantages of JIT delivery.

The most common storage system for the raw materials pipe and shapes are cantilever racks, specialized pallets, and open stacks.

CANTILEVER RACKS

Most cantilever racks in shipyards are fixed units constructed of scrap angle iron and pipe. These are inexpensive units, but are not as flexible and efficient as adjustable manufactured units. An optimized double-sided rack is shown in Figure VI-2 with a narrow-isle fork truck. These rack arms are inclined toward the center to keep stock from rolling out. The arms are also adjustable vertically along the supports to make maximum use of the space between the arms. The adjustable feature allows the storage system to change with changing storage needs.

Typically, 4-inch diameter pipe is the largest size normally stored inside on cantilever racks. The racks are generally arranged to accommodate narrow-isle fork trucks. Similar-sized structural items are also stored on racks inside. Larger-dimension items are stored in vertical

stacks for handling by overhead cranes, or outside on bunks. The height of the racks is usually 24 feet to take advantage of the maximum lift height of standard narrow-isle trucks.

Single-sided cantilever racks are used inside along building sides and along roadways and building sides outside. The underlying support structure is stronger to hold the unbalanced load, but space utilization is enhanced where otherwise wasted.

Large volume commodity distributors use double-sided cantilever racks up to 50 feet high. The racks also serve as the building structure. Specialized storage and retrieval (SR) systems, many of them automated storage and retrieval systems (AS/RS), ride on rails in the floor, or rails and tracks in the overhead of the building for stability at greater heights. However, these systems are relatively expensive and not appropriate for shipyards with intermittent material flows.

PALLETS

Specialized pallets have been developed for pipe and shapes raw material handling. Standard 4-foot by 4-foot pallets are not applicable. One such pallet seen at the USS/Kobe Steel Company Tubular Products plant in Lorain, Ohio, is called a "bolster" and shown in Figure VI-9. The bolsters are made from scrap pipe with tapered side supports. The width is designed for handling by straddle carriers. Each bolster is numbered to help track inventory.



source: USS/Kobe Steel Company

Figure VI-9
PIPE BOLSTERS

Similar pallets are in use at shipyards. Many of these have lifting eyes, either in the top of the vertical supports or in the base, for wire sling attachment. The vertical supports are arranged so that the pallets can be stacked. NASSCO has some large pallet baskets (Figure VI-10) that are used mainly for finished pipe spools and are handled by fork trucks. The shipyard pallets are mostly in-house designs, built both in the yards and at outside steel fabrication shops.



source: National Steel and Shipbuilding Company

Figure VI-10
PALLET BASKETS

STACKS

An orderly, stacked arrangement of material is generally referred to as a stack or a "bunk." This is a commonly used method for outside storage where land is inexpensive and handling speed is not critical. Handling equipment must be flexible and designed for rough terrain as outside storage areas are usually unpaved. Bunks are often used for larger-dimension pipe and shapes where use of racks becomes inefficient. Access to material is on the order of "last in, first out" so each stack should contain only one type of material to avoid unstacking and restacking for access to an item on the bottom.

Structural items are more conducive to stacks than pipe. They will not roll, are not as sensitive to uneven ground, and provide riggers with better hand and foot holds to climb the stack to attach slings and grabs. The need for riggers to climb the stack to attach lifting devices is a safety problem that should limit high stacks unless hands-off handling equipment is used.

Wide-flange I-beams are the easiest structures to stack because they are self supporting. One such stack arrangement is shown on the right side of Figure VI-11. This stack limits lifting devices to grabs, magnets or to a fork truck lifting the whole stack. An evenly spread out stack may take more space but allows lifting by a number of devices and is more stable for a larger number of items.



source: National Steel and Shipbuilding Company

Figure VI-11
I-BEAM STACK

Pipe is more difficult to handle in a stack because it can roll if the stack is not level. It is also difficult to use many lifting devices with the pipe stacked closely together. The rolling problem can be solved by the use of simple "clips" seen in use at La Barge Pipe and Tube, St. Louis, Missouri, and shown in Figure VI-12. The clips are made from steel angle with drilled edges and approximately one eighth the pipe diameter. The sharp edges dig into the wood blocking to prevent the clip from slipping.

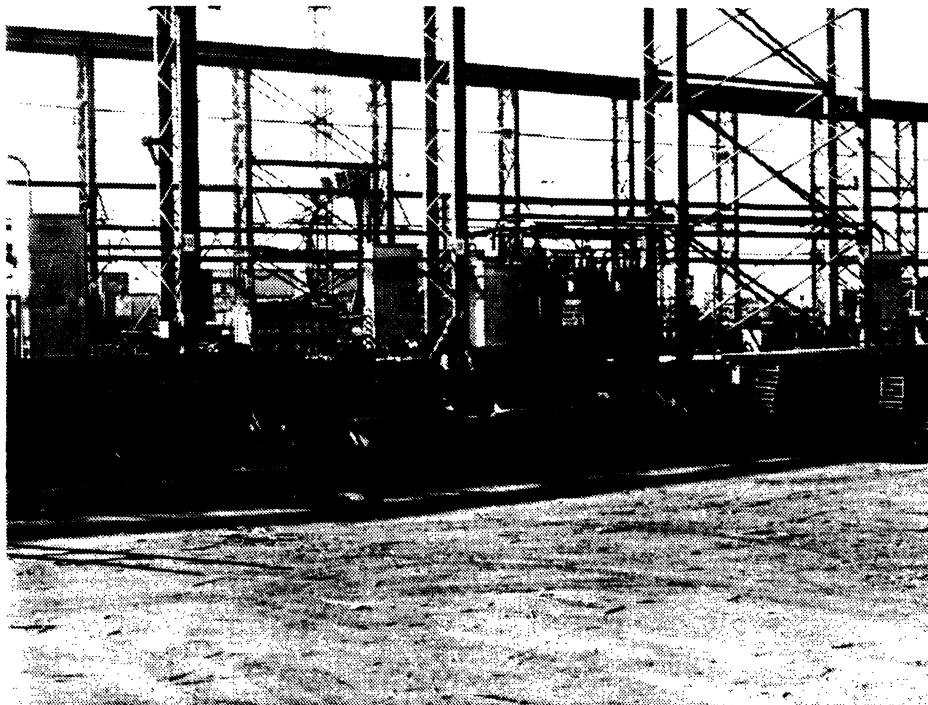

source: La Barge Pipe and Tube

Figure VI-12
PIPE STACK ANTI ROLL CLIPS

The need to separate pipe within a stack depends on the type of handling equipment being used. If slings or pipe grabs are being used, blocking should be used between rows and between each pipe as shown in Figure VI-13a. Otherwise the pipe must be manually manipulated for sling access, exposing riggers to unnecessary hazards. However, if a single-boom or end-grabs are used, pipe can be stacked very tightly as shown in Figure VI-13b. Fork lifts with bailers or lifter loaders require the rows to be separated, but the pipe in each row can be manipulated without blocking between the pipe. A fork truck is shown handling pipe from such a stack with a bailer in Figure VI-1.

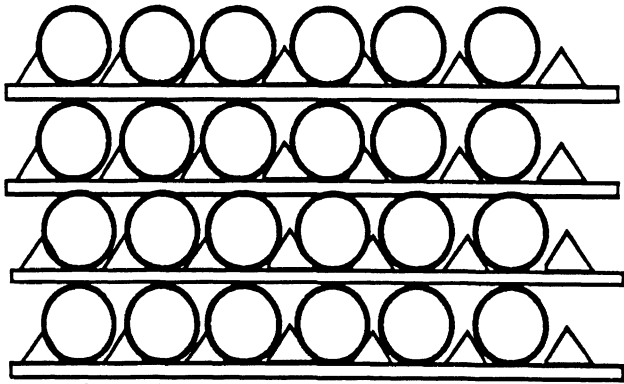

source: Study Team

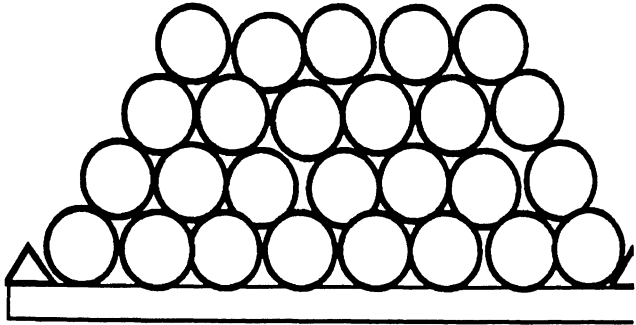

Figure 13a
BLOCKED PIPE STACK

Figure 13b
TIGHT PIPE STACK

BUILDINGS

The storage devices and arrangements described above can be used both inside and outside. There are many factors that should be considered when deciding to invest in an enclosed storage building. A well designed inside storage will result in cost savings in each area. They are:

- 1. physical protection from weather,*
- 2. access in adverse weather,*
- 3. availability of open land,*
- 4. protection from damage,*
- 5. protection from misuse or pilferage,*
- 6. efficiency of storage and retrieval,*
- 7. location of material, and*
- 8. inventory control.*

The weather in southern California has little effect on access to outside material, whereas in Maine outside materials must be dug out of the snow, and then handled in freezing conditions. Land costs vary around the country, from about \$800,000/acre for prime deep water access areas to \$10,000.00/acre in developed industrial areas, and can force a decision on using or acquiring large areas for outside storage or consolidating storage into a building.

It is difficult to quantify handling cost savings from any one of these considerations. However, the consensus of managers interviewed for this study, and recommendations from the literature is that if one or two of the general conditions above are critical, the overall systems savings will result in a relatively short payback for the capital investment.

A floor plan of a storage building arrangement is shown in Figure VI-14. This is the same arrangement seen in use at a tube distributor that wished to remain unidentified but was considered by other distributors as having the best system. Large-diameter products are stored in single column vertical stacks for movement by an overhead crane. Another area is a high cubic capacity rack for access by side loader fork truck. A transfer area is provided for unloading and loading tractor trailers.

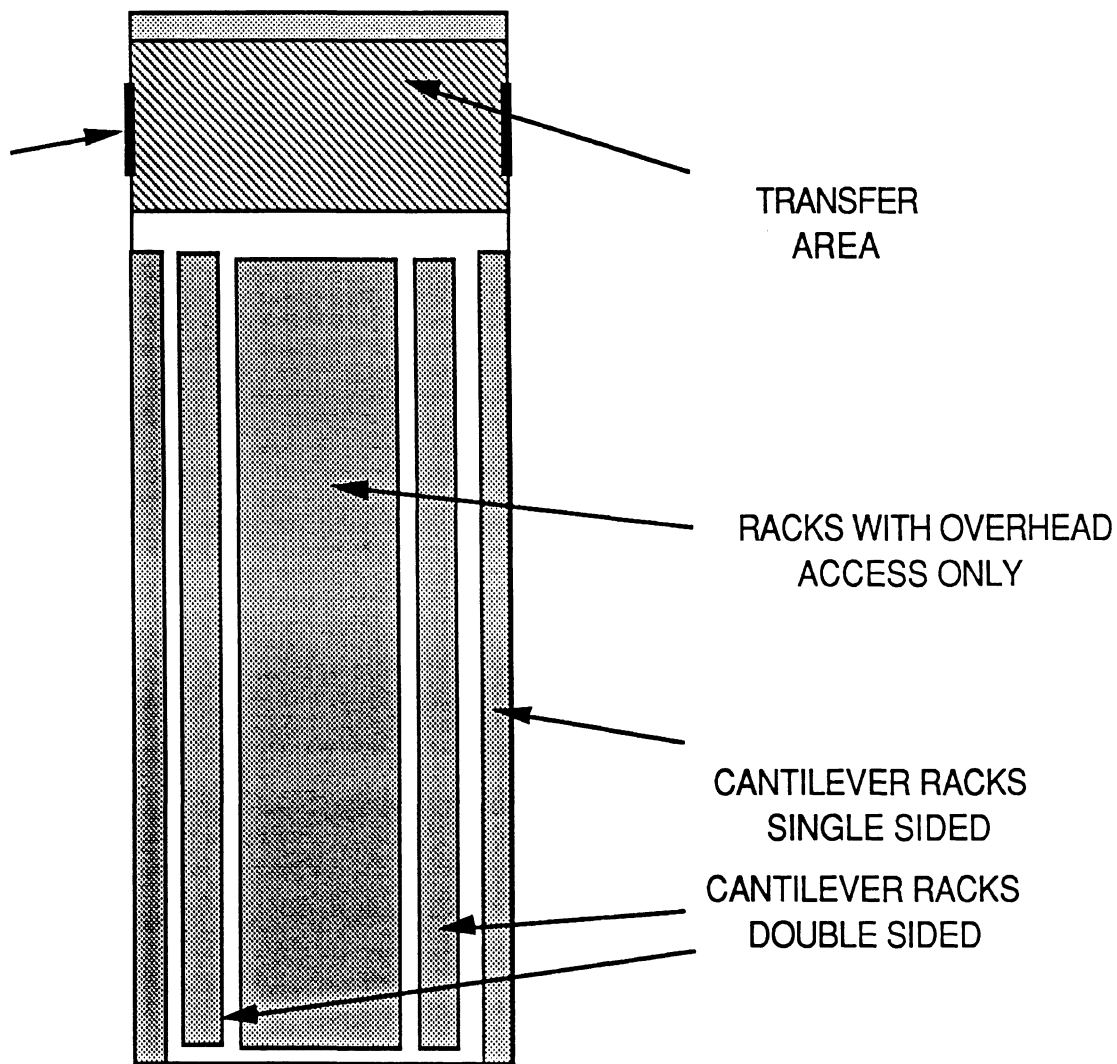

source: Study Team

Figure VI-14
STORAGE BUILDING

A composite of a generic storage building, including the bridge crane, was developed by UNITEC Construction Services of Ann Arbor, Michigan, and is included in Appendix C. It is considered representative of a typical storage structure. The costs included in the estimate include side wall structure sufficient to support the crane.

VII. MATERIAL HANDLING SYSTEM DESIGN

Before an engineering team can design a new material handling system or improve on an existing design, the team must first define the problem and its objectives. Problem definition for handling system design follows the same format as that used in Section II of this report. Following these definitions, data must be collected on the system of interest and all constraints must be identified. Once this information has been obtained a preliminary analysis can be performed.

DATA COLLECTION

During this phase of the design, the team must gather all the data and information required to understand the problems with the existing system. By obtaining this information, it is the designers goal to be able to conduct a quantitative analysis from which areas for improvement will be able to be identified. Data that of interest to the designers is listed in Table VII-1.

TABLE VII-1
DESIGN DATA

1. **Material Characteristics:** The characteristics that are usually of interest are the weight, size, shape, and material. Moreover, any precautions that must be taken to avoid damage and accidents are also of interest. An example would be the movement of copper nickel pipe.
2. **Space Available:** The amount of space available will affect decisions relative to storage and movement methods.
3. **Building Characteristics:** If a building is utilized anywhere in the system, the designer should be concerned with at least the locations of utilities, columns, obstructions, and openings.
4. **Flow Requirements:** Flow requirements refers to the amount of pipe and shapes, in this case, that must be put through the system. This information will affect the required capacity of the various movement methods.

source: Study Team

During the data collection phase of the project, the facility layout should be generated. This layout will be useful for determining flow process relationships between various geographic areas of the shipyard. Explanation of these ideas is best illustrated through an example. The example introduced in this section will be analyzed in detail in the case study section of the Appendix.

In Figure VII-1, the general layout of the sample shipyard is shown. This layout will be used as a tool to map the flow paths of both pipe and shapes. Once these flow paths are established, as shown in Figures VII-2 and VII-3, a more detailed analysis of these operations can be initiated. Concepts related to the analysis of the flow path information will be discussed in subsequent sections.

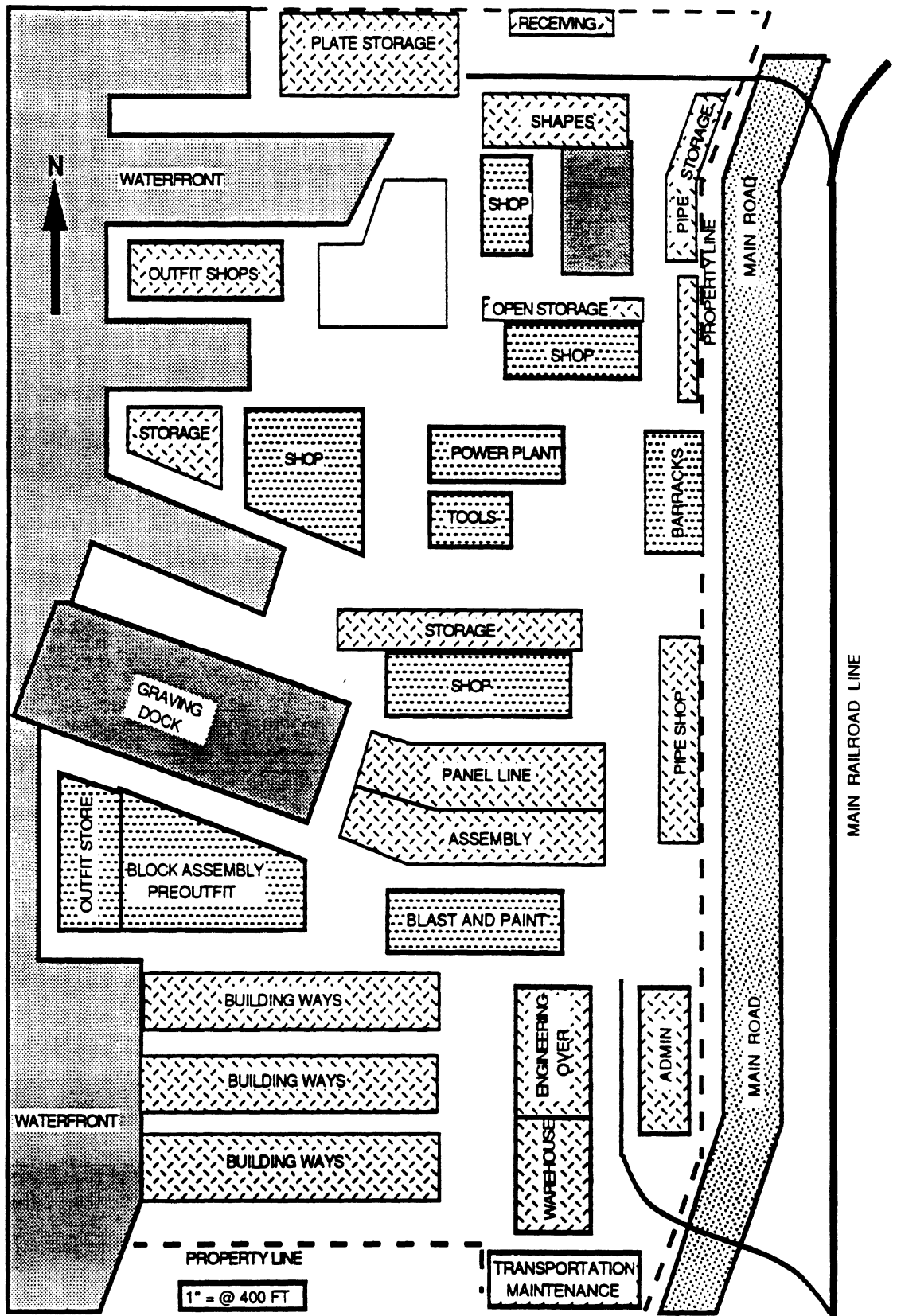
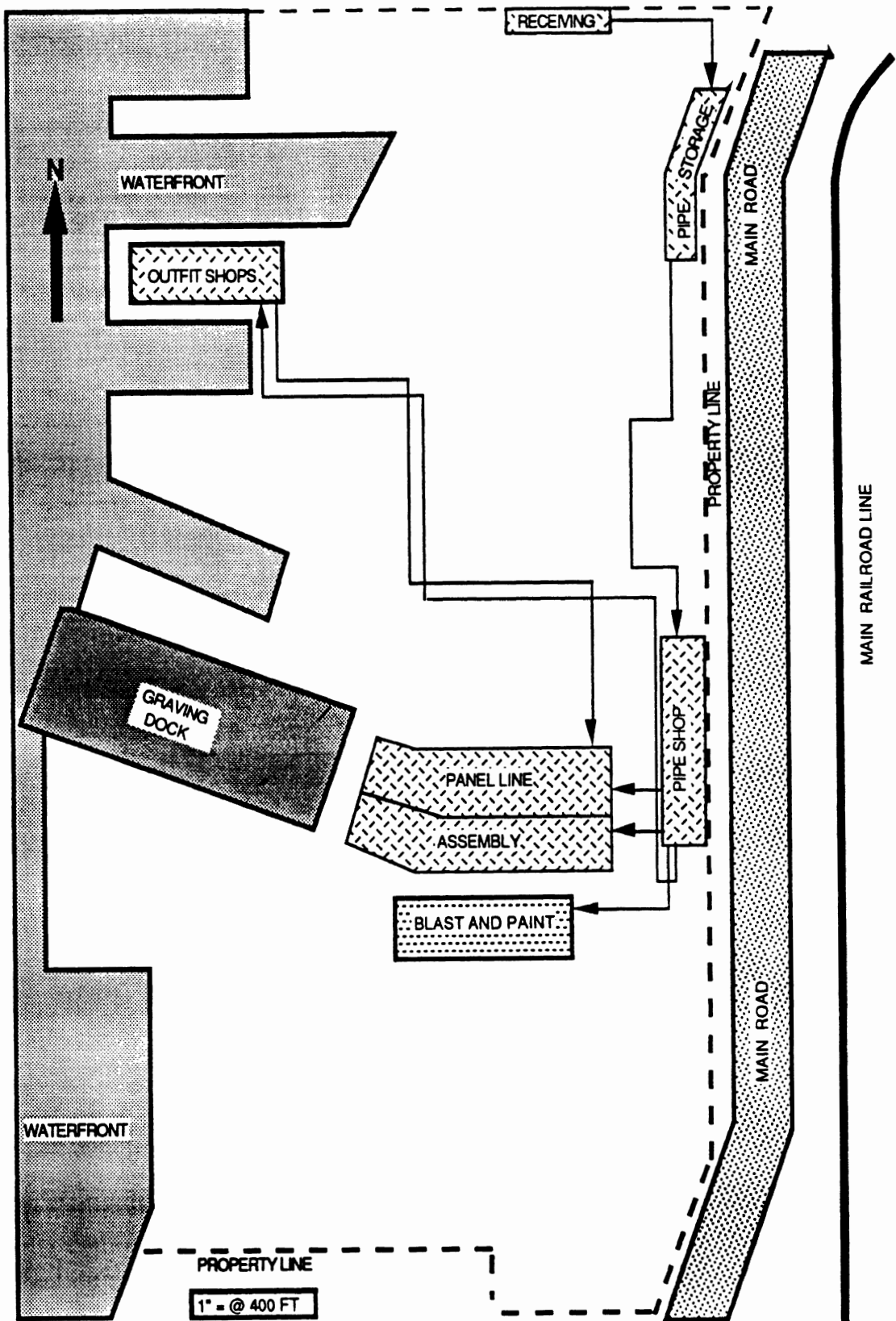
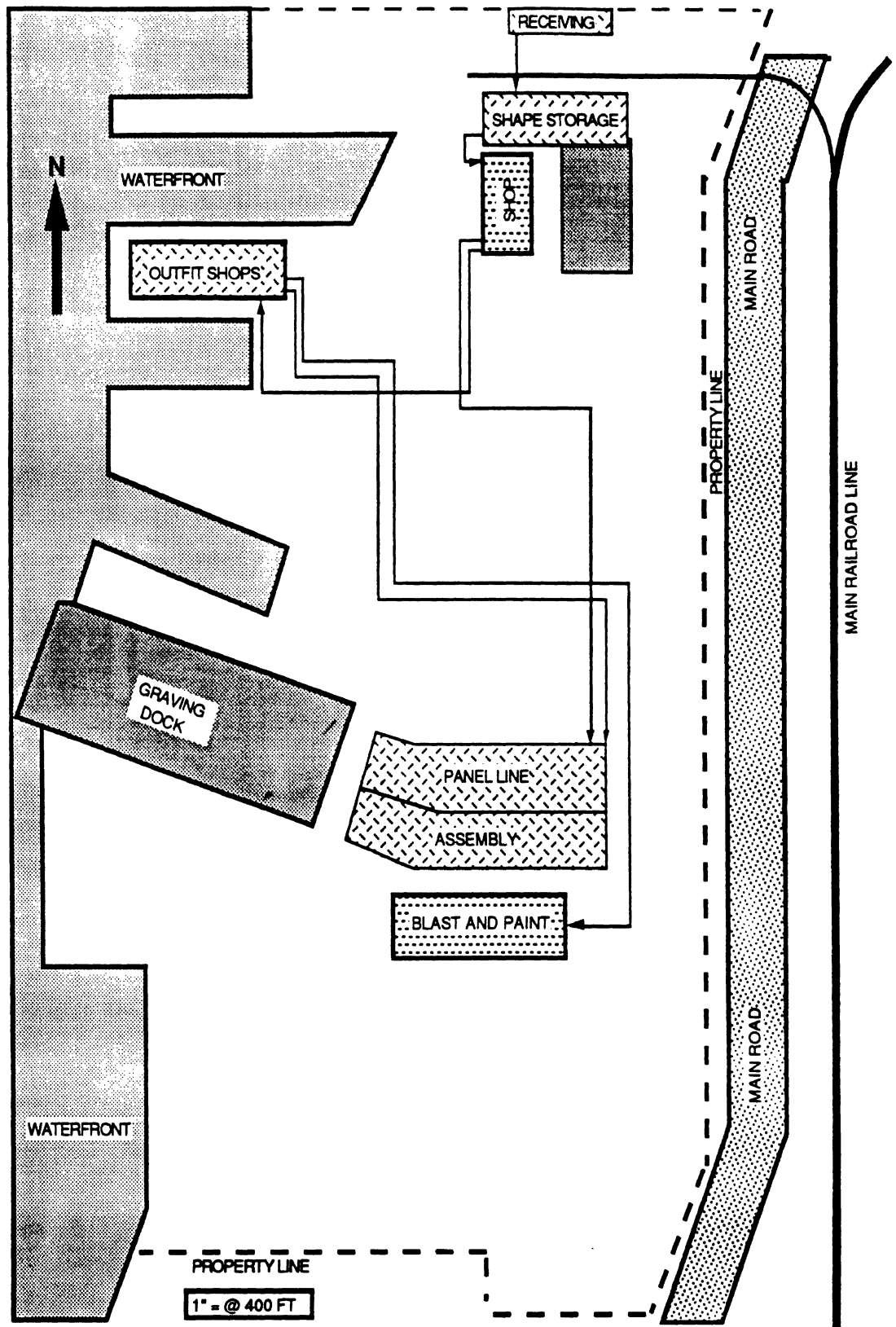

Figure VII-1
 SAMPLE SHIPYARD LAYOUT



Source: Study Team.

Figure VII-2
 SAMPLE SHIPYARD: PIPE FLOW PATHS



Source: Study Team.

Figure VII-3
 SAMPLE SHIPYARD: SHAPE FLOW PATHS

CONSTRAINTS

An important requirement prior to design is that all the constraints that will be imposed on the system be determined. The major constraints of concern are listed in Table VII-2.

TABLE VII-2
CONSTRAINTS

1. **Managerial:** Typically, the managerial constraints associated with a shipyard material handling process would be a financial budget and an "on-stream" deadline.
2. **Work Force Characteristics:** Worker characteristics that could be considered constraints are motivation levels, skill levels, and union discrepancies.
3. **Material:** Potential material constraints are the weight, size and shapes of the various items. Moreover, the volume of material the system is going to handle can also be a constraint.
4. **Space Available:** The amount of space available could limit the choices relative to the type of storage and the movement methods utilized.
5. **Building Characteristics:** The building characteristics that could typically be constraints are the locations of utilities, columns, obstructions, and openings.
6. **Equipment Characteristics:** The equipment characteristics that could be constraints are the costs, capabilities, and emissions.

source: Study Team

PRELIMINARY ANALYSIS

A useful initial analysis would be to implement a productivity study based on various ratios of outputs to inputs. There are presently no general numerical standards for any given ratio. These productivity ratios are primarily utilized for monitoring a system over some time period. As a result, the productivity analysis will be an on-going study that will have the capabilities to determine trends and to indicate when there is a need for corrective action. Some ratios that are typically utilized for this purpose are summarized in Table VII-3 and explained below.

**TABLE VII-3
MATERIAL HANDLING ANALYSIS RATIOS**

1. Material Handling Labor (MHL) Ratio:

$$\text{MHL} = \frac{\text{Personnel Assigned to MH Duties}}{\text{Total Operating Personnel}}$$

2. Handling Equipment Utilization (HEU) Ratio:

$$\text{HEU} = \frac{\text{Items Moved Per Hour}}{\text{Theoretical Capacity}}$$

3. Storage Space Utilization (SSU) Ratio:

$$\text{SSU} = \frac{\text{Storage Space Occupied}}{\text{Total Available Storage Space}}$$

4. Aisle Space Percentage (ASP) Ratio:

$$\text{ASP} = \frac{\text{Space Occupied By Aisles}}{\text{Total Space}}$$

5. Movement/Operation (MO) Ratio:

$$\text{MO} = \frac{\text{Number of Moves}}{\text{Number of Productive Operations}}$$

6. Damaged Load (DL) Ratio:

$$\text{DL} = \frac{\text{Number of Damaged Loads}}{\text{Total Number of Loads}}$$

source: Material Handling Institute, Inc. [12].

The Material Handling Labor ratio represents the number of personnel assigned to material handling duties in proportion to the entire work force. It can be determined on the basis of head count or payroll costs. Some support activities (maintenance, tool room, production control) are not devoted full time to material handling. An estimate of the percentage of the time spent on handling should be used for these areas.

A variation of this ratio, called the direct labor material handling ratio, can be used to measure the percentage of the direct labor that is spent on material handling. The required data can be obtained from work sampling or other analysis techniques.

The way the Handling Equipment Utilization (HEU) Ratio is determined will vary from one facility to the next. Therefore it is meaningful only if used to make relative comparisons, over a period of time, within a given operation. To use this ratio properly, one must first decide what is meant by theoretical capacity - or full utilization. For example, some engineers consider a piece of equipment fully utilized only when it is carrying a full load. On the other hand, others feel it is properly utilized when empty, but heading toward a loading station.

The Storage Space Utilization (SSU) Ratio is applied most frequently in warehousing and other storage operations. Cubic space should be measured rather than floor area. In collecting the data, keep track of the percentage of bin and rack openings that are empty. Of the ones that are occupied, note whether they are fully or partially utilized, and if practical, try to estimate the percentage of utilization.

The Aisle Space Percentage (ASP) Ratio is important to analyze because all space is becoming extremely costly in both warehousing and manufacturing. Aisles and traffic patterns should be laid out carefully in order to use available space most productively. The calculation should be based on cubic feet of total space. A low ASP figure may be as bad as one that is too high. A reasonable number of both traffic and access aisles must be provided to maintain desirable levels of throughput and productivity.

The Movement/Operation (MO) Ratio reflects the overall efficiency of material handling operations in the plant. It can indicate the number of handling and re-handling steps that are involved in receiving, storage, manufacturing and other departments. Typically, a high ratio will indicate an improvement opportunity, in the form of fewer handling steps, simplified operations, or use of mechanized equipment.

The Damaged Load Ratio (DL) indicates how effectively and properly crews are handling incoming and outgoing goods, and in-process materials. A program of sampling should be established to generate damage data.

In the preliminary analysis of the pipe and shapes movement process, the transportation routes and the lengths of these routes were determined. A layout of these routes is shown in Figure VII-4. Table VII-6 shows the lengths of these various routes.

Table VII-6
TRANSPORTATION ROUTES

ROUTE	DISTANCE (FT)	ROUTE	DISTANCE (FT)
A1-A	100	B-D	200
B1-B	100	D-C	200
A-G	1000	K-O	600
G-L	200	M-P	600
G-H	600	O-P	700
I-H	500	P-Q	200
J-K	400	Q-R	100
L-M	500	P-U	800
M-N	100	S-T	100
E-F	100	T-U	200
N-F	400	U-V	200
D-F	600	W-V	200

source: Study Team.

Other tools that are useful for monitoring a material handling process are "From-To" charts and "Flow Process" charts [18]. Examples of these charts are shown in Figures VI-5 and VI-6. The "Flow Process" chart is useful for tabulating the steps and moves in a given process. The information given in this chart will aid the designer in determining when corrective action may be needed. The "From-To" chart is used to determine the number of trips per day made between various locations in the shipyard. The information shown below the diagonal, indicates the number of "backtracking" trips were made between the two locations. This backtracking may considered an inefficiency. Detailed examples utilizing these charts are given in the case study.

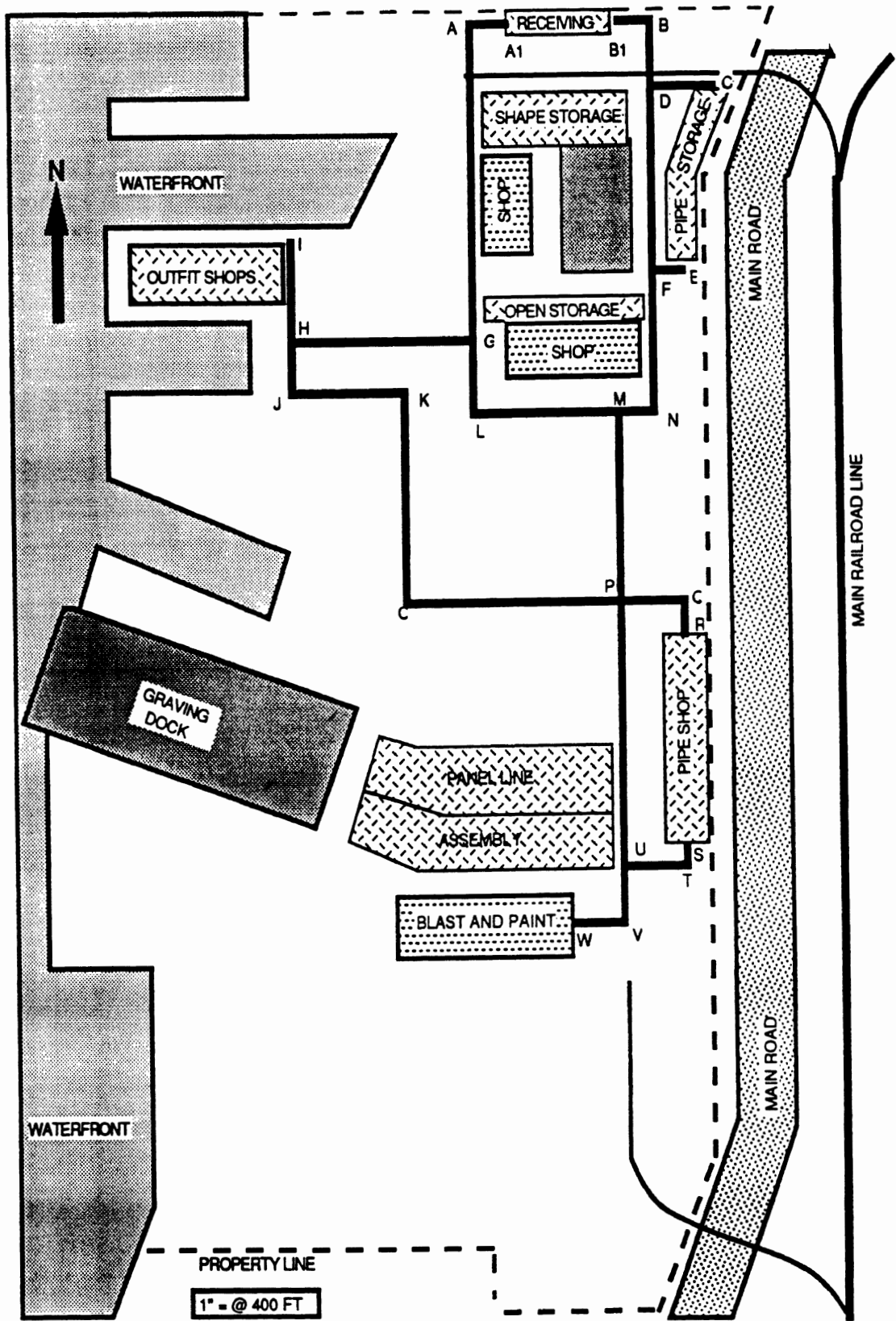

Source: Study Team.

Figure VII-4
 SAMPLE SHIPYARD: TRANSPORTATION ROUTES

Summary						JOB:	Question Each Detail	Analysis									
PRESENT		PROPOSED		DIFFERENCE				What?	When?								
NO.	TIME	NO.	TIME	NO.	TIME			Why?	How?								
<input type="radio"/>	OPERATION					Operator <input type="checkbox"/>	Material <input type="checkbox"/>	Date:									
<input type="checkbox"/>	TRANSPORTS					Chart Begins:		Number:									
<input type="checkbox"/>	INSPECTIONS					Chart Ends:		Page: of:									
<input type="checkbox"/>	DELAYS					Charted By:											
<input type="checkbox"/>	STORAGES																
Distance Traveled		ft.	ft.	ft.	ft.												
DETAILS OF (PRESENT/PROPOSED) METHOD	POSSIBILITIES														NOTES		
	OPERATION	TRANSPORT	INSPECTION	DELAY	STORAGE	DISTANCE (FT)	QUANTITY	TIME	BUDGET	COMBINE	SEQUENCE	PLANS	PERSON	DEPT		SAFER?	SAVED?
1)	<input type="radio"/>	<input type="checkbox"/>	<input type="checkbox"/>	<input type="checkbox"/>	<input type="checkbox"/>												
2)	<input type="radio"/>	<input type="checkbox"/>	<input type="checkbox"/>	<input type="checkbox"/>	<input type="checkbox"/>												
3)	<input type="radio"/>	<input type="checkbox"/>	<input type="checkbox"/>	<input type="checkbox"/>	<input type="checkbox"/>												
4)	<input type="radio"/>	<input type="checkbox"/>	<input type="checkbox"/>	<input type="checkbox"/>	<input type="checkbox"/>												
5)	<input type="radio"/>	<input type="checkbox"/>	<input type="checkbox"/>	<input type="checkbox"/>	<input type="checkbox"/>												
6)	<input type="radio"/>	<input type="checkbox"/>	<input type="checkbox"/>	<input type="checkbox"/>	<input type="checkbox"/>												
7)	<input type="radio"/>	<input type="checkbox"/>	<input type="checkbox"/>	<input type="checkbox"/>	<input type="checkbox"/>												
8)	<input type="radio"/>	<input type="checkbox"/>	<input type="checkbox"/>	<input type="checkbox"/>	<input type="checkbox"/>												
9)	<input type="radio"/>	<input type="checkbox"/>	<input type="checkbox"/>	<input type="checkbox"/>	<input type="checkbox"/>												
10)	<input type="radio"/>	<input type="checkbox"/>	<input type="checkbox"/>	<input type="checkbox"/>	<input type="checkbox"/>												
11)	<input type="radio"/>	<input type="checkbox"/>	<input type="checkbox"/>	<input type="checkbox"/>	<input type="checkbox"/>												
12)	<input type="radio"/>	<input type="checkbox"/>	<input type="checkbox"/>	<input type="checkbox"/>	<input type="checkbox"/>												
13)	<input type="radio"/>	<input type="checkbox"/>	<input type="checkbox"/>	<input type="checkbox"/>	<input type="checkbox"/>												
14)	<input type="radio"/>	<input type="checkbox"/>	<input type="checkbox"/>	<input type="checkbox"/>	<input type="checkbox"/>												
15)	<input type="radio"/>	<input type="checkbox"/>	<input type="checkbox"/>	<input type="checkbox"/>	<input type="checkbox"/>												
16)	<input type="radio"/>	<input type="checkbox"/>	<input type="checkbox"/>	<input type="checkbox"/>	<input type="checkbox"/>												
17)	<input type="radio"/>	<input type="checkbox"/>	<input type="checkbox"/>	<input type="checkbox"/>	<input type="checkbox"/>												
18)	<input type="radio"/>	<input type="checkbox"/>	<input type="checkbox"/>	<input type="checkbox"/>	<input type="checkbox"/>												
19)	<input type="radio"/>	<input type="checkbox"/>	<input type="checkbox"/>	<input type="checkbox"/>	<input type="checkbox"/>												
20)	<input type="radio"/>	<input type="checkbox"/>	<input type="checkbox"/>	<input type="checkbox"/>	<input type="checkbox"/>												
21)	<input type="radio"/>	<input type="checkbox"/>	<input type="checkbox"/>	<input type="checkbox"/>	<input type="checkbox"/>												
22)	<input type="radio"/>	<input type="checkbox"/>	<input type="checkbox"/>	<input type="checkbox"/>	<input type="checkbox"/>												
23)	<input type="radio"/>	<input type="checkbox"/>	<input type="checkbox"/>	<input type="checkbox"/>	<input type="checkbox"/>												
24)	<input type="radio"/>	<input type="checkbox"/>	<input type="checkbox"/>	<input type="checkbox"/>	<input type="checkbox"/>												
25)	<input type="radio"/>	<input type="checkbox"/>	<input type="checkbox"/>	<input type="checkbox"/>	<input type="checkbox"/>												
26)	<input type="radio"/>	<input type="checkbox"/>	<input type="checkbox"/>	<input type="checkbox"/>	<input type="checkbox"/>												
27)	<input type="radio"/>	<input type="checkbox"/>	<input type="checkbox"/>	<input type="checkbox"/>	<input type="checkbox"/>												
28)	<input type="radio"/>	<input type="checkbox"/>	<input type="checkbox"/>	<input type="checkbox"/>	<input type="checkbox"/>												
29)	<input type="radio"/>	<input type="checkbox"/>	<input type="checkbox"/>	<input type="checkbox"/>	<input type="checkbox"/>												

source: Study Team.

Figure VII-5
FLOW PROCESS CHARTS

To From	A	B	C	D	E	F	G	H	I	J	K
A											
B											
C											
D											
E											
F											
G											
H											
I											
J											
K											

source: Kulweic [12]

Figure VII-7
FROM-TO CHART

DESIGN SELECTION

The preparation phase of the material handling design process will lay the foundation for a successful continuation of the project. This phase consists of a review of all resources, time schedules, and organizational constraints that will affect the design process.

During this stage, various design concept alternatives must be selected. The purpose of this phase is to begin to identify the "general" characteristics of the material handling systems options that will be considered. Eastman [6] recommends that between three and five alternatives be chosen. More than five alternatives delays the design process and wastes time and money that could be more effectively spent in other areas.

In the case of pipe and shapes, decisions made at this level of design could be to utilize fork lifts, straddle carriers, and gantry cranes as the primary movement mechanisms in the handling system. Also, cantilever racks and stacked bunks could be the primary storage techniques. Moreover, rotating stackers and racks could be utilized for staging for processing. Detailed characteristics relative to the various types of machinery being considered will be specified in subsequent design stages.

The "best" alternative is the alternative that is most effective in meeting the objectives set forth by the problem statement within the constraints that are imposed. At this stage the designers should verify that the option that has been selected is attempting to solve the problem and meet the system objectives.

An economic analysis must be performed on the chosen alternative. The objective of this analysis is to utilize engineering economic analysis techniques to evaluate the material handling alternatives available to the shipyard. The four primary analysis tools, discussed in the case study, are the:

1. *Labor Cost Analysis,*
2. *After Tax Rate of Return Analysis (ROR),*
3. *Payback Analysis, and the*
4. *Equivalent Uniform Annual Cost Analysis (EUAC)*

The block design phase is performed next and requires that the designers specify some of the details of the major system components. These details could include the capacity of the rotating stackers, the span of the gantry cranes, the length of the conveyor sections in the pipe shop, or the capacity of the straddle carriers and fork lifts.

After the above details have been specified, the designers can begin to sketch the various systems on the general layout of the shipyard. During this exercise, the design team identifies areas where the proposed system does not fit or areas where there are system interferences.

The detailed design phase follows and requires the design team to specify and dimension all components necessary to implement the system. The end result of this design phase is a system design ready to be implemented through the purchase and installation of equipment, components, parts, and materials.

Throughout the design process the design team should be in constant contact with all the departments affected by the material handling system. The reasons for this communication suggested by Eastman [6] are:

- 1. Final acceptance and successful implementation of the new materials handling system are highly dependent on the attitudes of those operating the system and of those whose work depends on it.*
- 2. Those affected may have special requirements that need to be incorporated. Conversely, they may know pitfalls that must be avoided.*
- 3. Others may have very good suggestions concerning the system.*
- 4. Some persons may be in a position to influence management's decision on all or part of the system. It is a discouraging waste of time to have a proposed design turned down or materially modified because of objections of operating personnel, particularly if these objections could have been avoided by earlier discussions.*

VIII. CASE STUDY

The management of a shipyard determined that the handling and storage system for pipe and shapes was in need of reorganization. Tools used for their analysis were:

1. *Flow Process Charts,*
2. *From - To Charts, and*
3. *Shipyard Layout Charts.*

For simplicity, detailed examples utilizing these charts have been omitted. However, information obtained from these charts is used to generate the labor cost analysis show in Table VIII-1.

In the system design section, several system performance indices were presented. As discussed in that section, the primary use of these indices is to continuously monitor a system once in operation. Thus, in this case study, no attempt will be made to estimate the time history of the numerical values of these ratios. The primary objective of this case study is to perform an engineering economic analysis on various material handling system alternatives.

The material receiving area at the north end of the yard (yard layout was shown in Figure VII-I) was adequate for unloading trucks and rail cars. Standard fork trucks and portable cranes were utilized during the unloading process. However, the operators of this machinery, from the transportation department, were not familiar with handling these types of materials. Thus, the unloading time appeared to be inefficient. The problems encountered were:

1. *unsecured loads on forks required slow handling movements and occasionally resulted in dropped loads;*
2. *use of cranes required two riggers to the handle loads;*
3. *the least expensive way to receive large orders of steel pipe and shapes was by gondola rail car but unloading expenses were high; and*
4. *fork trucks were unable to access the entire load from one side since they did not have enough "reach." Thus, these fork trucks required access to both sides of the load.*

Solutions considered were to:

- 1. provide a bailer to clamp loads on fork trucks to stabilize loads; and*
- 2. purchase a lifter/loader capable of unloading rail cars (without extra riggers) from one side.*

As trucks were unloaded, the material was placed in an area next to the receiving office, checked and entered into inventory. Then the interim, long term (before processing) storage area was identified and transportation was arranged to transport the material to this site. The problems with this process were:

- 1. material was handled twice and re-transported; and*
- 2. material was inventoried twice.*

Solutions considered were:

- 1. redesign the long term storage area to receive material directly from the shipper; and*
- 2. use the lifter/loader for both unloading and transporting.*

Present outside storage capacity consisted of welded cantilever racks, built by the yard, and bunked areas on the ground. As storage needs increased, various areas of the shipyard were utilized for storage. Thus, the increase in storage sites caused the storage, retrieval, and transportation processes to become cumbersome.

COST ANALYSIS

The objective of this cost analysis is to utilize engineering economic analysis techniques to evaluate the material handling alternatives available

to the shipyard in this case study. In this case study, the existing system and two alternatives are evaluated. The four primary analysis tools used in the analysis were:

1. *Labor Cost Analysis.*
2. *After Tax Rate of Return Analysis (ROR).*
3. *Payback Analysis.*
4. *Equivalent Uniform Annual Cost Analysis (EUAC).*

All of these analyses were performed with Microsoft Excel® for the Apple Macintosh®.

LABOR COST ANALYSIS

One of the primary requirements of each of the analysis techniques, discussed above, is to quantify the operating expenditures of each of the alternatives. The operating expenditures of concern in this case study are labor and equipment costs. Table VIII-1 shows the number of manhours and associated cost of the pipe and shapes handling system processing a rail car load of material.

The labor cost analysis of the existing system, shown in Table VIII-1, can be generated with the aid of flow process charts, from-to charts, and distance tables, all of which are explained in Section VII of this report.

In Table VIII-1, task descriptions 1, 2 and 3 all occur simultaneously. In the existing system, it takes four individuals three hours to unload a rail car. These four individuals are two laborers, one supervisor, and one equipment operator. In addition to this unloading crew, one laborer is required for classification and one equipment operator (fork lift) is required for movement of the material to temporary storage. The material is then moved to normal storage by one equipment operator (flat bed trailer with dolly and fork lift). The material, once at the normal storage site, will then be unloaded by another equipment operator (fork lift). The material is stored in open bunks. The retrieval of this material is performed by one equipment operator (fork lift). This retrieval operation, task description #6 in Table VIII-1, has been observed to take twice as long as the unloading process, task description #5 in Table VIII-1, since the pipe and shapes are typically retrieved individually, but are unloaded in greater quantities. Movement to the shop will be performed by one equipment operator (flat bed trailer with dolly). Once at the shop site, the material is unloaded by another equipment operator (fork lift).

**Table VIII-1
LABOR COST ANALYSIS, EXISTING SYSTEM**

Existing System					
NOTE: All time estimates are per rail car load.					
Task Description	Personnel Description	No. of Personnel	Manhours Per Worker	\$/Manhour	Labor Cost
1.Unloading	Labor	2	3.00	\$10.00	\$60.00
	Supervisor	1	3.00	\$20.00	\$60.00
	Equipment Op.	1	3.00	\$20.00	\$60.00
2.Classification	Labor	1	3.00	\$15.00	\$45.00
3.Temporary Storage	Equipment Op.	1	3.00	\$18.00	\$54.00
4.Move to Storage	Equipment Op.	1	8.00	\$18.00	\$144.00
5.Unload	Equipment Op.	1	4.00	\$18.00	\$72.00
6.Retrieve (Load)	Equipment Op.	1	8.00	\$18.00	\$144.00
7.Move to Shop	Equipment Op.	1	8.00	\$18.00	\$144.00
	Equipment Op.	1	4.00	\$18.00	\$72.00
9.Stage for Processing	Receiving	1	8.00	\$20.00	\$160.00
	Equipment Op.	1	8.00	\$18.00	\$144.00
10.Move into Shop	Equipment Op.	1	8.00	\$18.00	\$144.00
TOTALS:					
Manhours	74.00				
Labor Cost	\$1,303.00				

source: Study team

The material is then moved by two shop workers into storage (staging) racks outside the shop. Finally, the material is then sorted and moved into the shop to be processed by one equipment operator (fork lift).

Table VIII-1 indicates that approximately 74 manhours are required by the existing system to process a rail car load comparable in size to that of one rail car shipment. This seventy four manhours translates into \$1,303 in labor costs. The development of the alternative systems will focus on the minimization of this cost.

Alternative #1 adds the following to the existing system:

1. *bailer for fork lift (secure loads on forks);*
2. *outside, side loading cantilever storage racks;*
3. *storage silo for pipe shop.*

As a result of the acquisition of these devices, the labor costs will be reduced by \$520 and manhours will be reduced by 28 hours per rail car

load. Thus, alternative #1 will require a total of 46 manhours which translates into \$783 to process the rail car load as shown in Table VIII-2.

Table VIII-2
LABOR COST ANALYSIS, ALTERNATIVE #1

NOTE: All time estimates are per rail car load.					
Task Description	Personnel Description	No. of Personnel	Manhours Per Worker	\$/Manhour	Labor Cost
1.Unloading	Labor	2	3.00	\$10.00	\$60.00
	Supervisor	1	3.00	\$20.00	\$60.00
	Equipment Op.	1	3.00	\$20.00	\$60.00
2.Classification	Labor	1	3.00	\$15.00	\$45.00
3.Temporary Storage	Equipment Op.	1	3.00	\$18.00	\$54.00
4.Move to Storage	Equipment Op.	1	8.00	\$18.00	\$144.00
5.Unload	Equipment Op.	1	3.00	\$18.00	\$54.00
6.Retrieve (Load)	Equipment Op.	1	6.00	\$18.00	\$108.00
7.Move to Shop	Equipment Op.	1	8.00	\$18.00	\$144.00
8.Unload	Equipment Op.	1	3.00	\$18.00	\$54.00
9.Stage for Processing	Receiving	1	0.00	\$20.00	\$0.00
	Equipment Op.	1	0.00	\$18.00	\$0.00
10.Move into Shop	Equipment Op.	1	0.00	\$18.00	\$0.00
TOTALS:					
Manhours	46.00				
Labor Cost	\$783.00				

source: Study Team

Alternative #1 offers labor savings in the areas of unloading, retrieval, staging for processing, and movement into the shop. The corresponding reduction in labor savings is evident in task descriptions 5, 6, 8, 9, and 10. The loading and unloading will become more efficient because of the added stability of the load on the fork lift due to the bailer. The cantilever storage racks will aid in the efficiency of the loading and unloading processes associated with the normal storage site. The acquisition of the rotating stacker will eliminate the labor expenditures in the areas of staging for processing and movement into the shop. The reason for the elimination of these expenditures is because all the material can be directly unloaded into the pipe silo.

Alternative #2 adds the following to the existing system:

1. *Pettibone cary lift;*
2. *outside, side loading cantilever storage racks; and*
3. *pipe silo for pipe shop.*

The main difference between alternative #1 and alternative #2 is that alternative #2 has the capabilities to unload and load transportation vehicles more economically and safely. In addition, alternative #2 will eliminate the need for temporary storage since the Cary Lift will be able to transport the material directly from the receiving area to the storage facility.

Comparing alternative #2 with the existing system, alternative #2 will reduce the labor expenditures by 47 hours and \$817.

**Table VIII-3
LABOR COST ANALYSIS, ALTERNATIVE #2**

NOTE: All time estimates are per rail car load.					
NOTE: Steps 4 and 5 are performed by the same operator					
Task Description	Personnel Description	No. of Personnel	Manhours Per Worker	\$/Manhour	Labor Cost
1. Unloading	Labor	0	0.00	\$10.00	\$0.00
	Supervisor	1	1.00	\$20.00	\$20.00
	Equipment Op.	1	1.50	\$20.00	\$30.00
2. Classification	Labor	1	1.50	\$15.00	\$22.50
3. Temporary Storage	Equipment Op.	0	0.00	\$18.00	\$0.00
4. Move to Storage	Equipment Op.	1	8.00	\$18.00	\$144.00
5. Unload	Equipment Op.	1	1.50	\$18.00	\$27.00
6. Retrieve (Load)	Equipment Op.	1	4.00	\$18.00	\$72.00
7. Move to Shop	Equipment Op.	1	8.00	\$18.00	\$144.00
8. Unload	Equipment Op.	1	1.50	\$18.00	\$27.00
9. Stage for Processing	Receiving	0	0.00	\$20.00	\$0.00
	Equipment Op.	0	0.00	\$18.00	\$0.00
10. Move into Shop	Equipment Op.	0	0.00	\$18.00	\$0.00
TOTALS:					
Manhours		27.00			
Labor Cost					\$486.50

source: Study Team

Thus, alternative #2 will require a total of 27 manhours which translates into \$487 to process the rail car load as shown in Table VIII-3.

The major advantage of alternative #2 is the increased capacity to load, unload, and transport pipe and shapes more efficiently due to the ability of the Pettibone Cary Lift. As a result, the manhour expenditures associated with unloading, classification, and temporary storage are decreased significantly. The labor portion of the first unloading operation is eliminated since the equipment operator needs no additional aid to unload

a rail car or a flatbed truck. The temporary storage phase is also eliminated since the Cary Lift will transport the pipe and shapes directly to the normal storage area.

**Table VIII-4
AFTER TAX RATE OF RETURN ANALYSIS (ROR)
ALTERNATIVE #1**

Initial Investment=\$380,000.00 # Depreciating Years: 20 Increase in Annual Income=\$24,960.00 Note: 48 rail car loads received per year.							
Year	Before Tax Cash Flow	Depreciation (Sum-of-Digits)	Taxable Income	Income Tax 33.00%	After Tax Cash Flow	Rate of Return	Present Worth
0	(\$380,000.00)	-	-	-	-	-	-
1	\$24,960.00	\$36,190.48	(\$11,230.48)	\$3,706.06	\$28,666.06	2.07%	\$28,084.43
2	\$24,960.00	\$34,380.95	(\$9,420.95)	\$3,108.91	\$28,068.91	2.07%	\$26,941.44
3	\$24,960.00	\$32,571.43	(\$7,611.43)	\$2,511.77	\$27,471.77	2.07%	\$25,833.28
4	\$24,960.00	\$30,761.90	(\$5,801.90)	\$1,914.63	\$26,874.63	2.07%	\$24,758.99
5	\$24,960.00	\$28,952.38	(\$3,992.38)	\$1,317.49	\$26,277.49	2.07%	\$23,717.67
6	\$24,960.00	\$27,142.86	(\$2,182.86)	\$720.34	\$25,680.34	2.07%	\$22,708.40
7	\$24,960.00	\$25,333.33	(\$373.33)	\$123.20	\$25,083.20	2.07%	\$21,730.33
8	\$24,960.00	\$23,523.81	\$1,436.19	(\$473.94)	\$24,486.06	2.07%	\$20,782.60
9	\$24,960.00	\$21,714.29	\$3,245.71	(\$1,071.09)	\$23,888.91	2.07%	\$19,864.38
10	\$24,960.00	\$19,904.76	\$5,055.24	(\$1,668.23)	\$23,291.77	2.07%	\$18,974.87
11	\$24,960.00	\$18,095.24	\$6,864.76	(\$2,265.37)	\$22,694.63	2.07%	\$18,113.28
12	\$24,960.00	\$16,285.71	\$8,674.29	(\$2,862.51)	\$22,097.49	2.07%	\$17,278.83
13	\$24,960.00	\$14,476.19	\$10,483.81	(\$3,459.66)	\$21,500.34	2.07%	\$16,470.80
14	\$24,960.00	\$12,666.67	\$12,293.33	(\$4,056.80)	\$20,903.20	2.07%	\$15,688.43
15	\$24,960.00	\$10,857.14	\$14,102.86	(\$4,653.94)	\$20,306.06	2.07%	\$14,931.04
16	\$24,960.00	\$9,047.62	\$15,912.38	(\$5,251.09)	\$19,708.91	2.07%	\$14,197.92
17	\$24,960.00	\$7,238.10	\$17,721.90	(\$5,848.23)	\$19,111.77	2.07%	\$13,488.41
18	\$24,960.00	\$5,428.57	\$19,531.43	(\$6,445.37)	\$18,514.63	2.07%	\$12,801.84
19	\$24,960.00	\$3,619.05	\$21,340.95	(\$7,042.51)	\$17,917.49	2.07%	\$12,137.58
20	\$24,960.00	\$1,809.52	\$23,150.48	(\$7,639.66)	\$17,320.34	2.07%	\$11,495.00
		\$380,000.00					\$379,999.53
Rate of Return= 2.07%							

source: Study Team

AFTER TAX RATE OF RETURN ANALYSIS (ROR)

The rate of return analysis technique is used to determine the interest rate that will make the summation of the present worth of the annual after tax cash flow equal to the initial capital investment. This rate of return interest rate is useful for comparing competing alternatives.

Table VIII-4 shows the rate of return to be 2.07% for alternative #1. This is the interest rate where the discount present value of the benefit stream equals the discounted present value of the cash out flow stream.

The initial capital investment for alternative #1 was derived as follows:

1. <i>Bailer for Fork Lift (secure loads on forks)</i>	\$30,000
2. <i>Outside, side loading cantilever storage racks (10) @ \$20,000</i>	\$200,000
3. <i>Pipe Silo for Pipe Shop</i>	<u>\$150,000</u>
	<u>\$380,000</u>

Table VIII-5 shows the rate of return to be 4.12% for alternative #2.

The initial capital investment for alternative #2 was derived as follows:

1. <i>Pettibone Carry Lift @ 60% utilization for pipe & shapes material handling</i>	\$120,000
2. <i>Outside, side loading cantilever storage racks (10) @ \$20,000</i>	\$200,000
3. <i>Pipe Silo for Pipe Shop</i>	<u>\$150,000</u>
	<u>\$470,000</u>

As a result of the rate of return analysis, alternative #2 is superior.

PAYBACK ANALYSIS

The objective of the payback analysis is to determine the time in which the cumulative revenues generated by the investment equal the initial investment cost. Table VII-VI indicates that alternative #1 recaptured their initial investment cost in 15.6 years.

Table VIII-6 indicates that alternative #2 recaptures the initial investment cost in 12.8 years. Thus, the payback analysis, in addition to the rate of return analysis, shows alternative #2 to be superior to alternative #1.

Table VIII-5
AFTER TAX RATE OF RETURN ANALYSIS (ROR)
ALTERNATIVE #2

Initial Investment=\$470,000.00 # Depreciating Years: 20 Increase in Annual Income=\$39,120.00 Note: 48 rail car loads received per year.								
Year	Before Tax Cash Flow	Depreciation (Sum-of-Digits)	Taxable Income	Income Tax 33.00%	After Tax Cash Flow	Rate of Return	Present Worth	
0	(\$470,000.00)	-	-	-	-	-	-	
1	\$39,120.00	\$44,761.90	(\$5,641.90)	\$1,861.83	\$40,981.83	4.12%	\$39,360.94	
2	\$39,120.00	\$42,523.81	(\$3,403.81)	\$1,123.26	\$40,243.26	4.12%	\$37,122.87	
3	\$39,120.00	\$40,285.71	(\$1,165.71)	\$384.69	\$39,504.69	4.12%	\$35,000.25	
4	\$39,120.00	\$38,047.62	\$1,072.38	(\$353.89)	\$38,766.11	4.12%	\$32,987.47	
5	\$39,120.00	\$35,809.52	\$3,310.48	(\$1,092.46)	\$38,027.54	4.12%	\$31,079.15	
6	\$39,120.00	\$33,571.43	\$5,548.57	(\$1,831.03)	\$37,288.97	4.12%	\$29,270.19	
7	\$39,120.00	\$31,333.33	\$7,786.67	(\$2,569.60)	\$36,550.40	4.12%	\$27,555.70	
8	\$39,120.00	\$29,095.24	\$10,024.76	(\$3,308.17)	\$35,811.83	4.12%	\$25,931.04	
9	\$39,120.00	\$26,857.14	\$12,262.86	(\$4,046.74)	\$35,073.26	4.12%	\$24,391.79	
10	\$39,120.00	\$24,619.05	\$14,500.95	(\$4,785.31)	\$34,334.69	4.12%	\$22,933.74	
11	\$39,120.00	\$22,380.95	\$16,739.05	(\$5,523.89)	\$33,596.11	4.12%	\$21,552.87	
12	\$39,120.00	\$20,142.86	\$18,977.14	(\$6,262.46)	\$32,857.54	4.12%	\$20,245.35	
13	\$39,120.00	\$17,904.76	\$21,215.24	(\$7,001.03)	\$32,118.97	4.12%	\$19,007.54	
14	\$39,120.00	\$15,666.67	\$23,453.33	(\$7,739.60)	\$31,380.40	4.12%	\$17,835.98	
15	\$39,120.00	\$13,428.57	\$25,691.43	(\$8,478.17)	\$30,641.83	4.12%	\$16,727.36	
16	\$39,120.00	\$11,190.48	\$27,929.52	(\$9,216.74)	\$29,903.26	4.12%	\$15,678.53	
17	\$39,120.00	\$8,952.38	\$30,167.62	(\$9,955.31)	\$29,164.69	4.12%	\$14,686.50	
18	\$39,120.00	\$6,714.29	\$32,405.71	(\$10,693.89)	\$28,426.11	4.12%	\$13,748.42	
19	\$39,120.00	\$4,476.19	\$34,643.81	(\$11,432.46)	\$27,687.54	4.12%	\$12,861.57	
20	\$39,120.00	\$2,238.10	\$36,881.90	(\$12,171.03)	\$26,948.97	4.12%	\$12,023.36	
		\$470,000.00						\$470,000.63
Rate of Return= 4.12%			4					
			.					
			1					
			2					
			%					

source: Study Team

**Table VIII-6
PAYBACK ANALYSIS, ALTERNATIVE #1**

Initial Investment=\$380,000.00						
# Depreciating Years: 20						
Increase in Annual Income=\$24,960.00						
Note: 48 rail car loads received per year.						
Year	Before Tax Cash Flow	Depreciation (Sum-of-Digits)	Taxable Income	Income Tax 33.00%	After Tax Cash Flow	Cumulative Cash Flow
0	(\$380,000.00)	-	-	-	-	
1	\$24,960.00	\$36,190.48	(\$11,230.48)	\$3,706.06	\$28,666.06	(\$351,333.94)
2	\$24,960.00	\$34,380.95	(\$9,420.95)	\$3,108.91	\$28,068.91	(\$323,265.03)
3	\$24,960.00	\$32,571.43	(\$7,611.43)	\$2,511.77	\$27,471.77	(\$295,793.26)
4	\$24,960.00	\$30,761.90	(\$5,801.90)	\$1,914.63	\$26,874.63	(\$268,918.63)
5	\$24,960.00	\$28,952.38	(\$3,992.38)	\$1,317.49	\$26,277.49	(\$242,641.14)
6	\$24,960.00	\$27,142.86	(\$2,182.86)	\$720.34	\$25,680.34	(\$216,960.80)
7	\$24,960.00	\$25,333.33	(\$373.33)	\$123.20	\$25,083.20	(\$191,877.60)
8	\$24,960.00	\$23,523.81	\$1,436.19	(\$473.94)	\$24,486.06	(\$167,391.54)
9	\$24,960.00	\$21,714.29	\$3,245.71	(\$1,071.09)	\$23,888.91	(\$143,502.63)
10	\$24,960.00	\$19,904.76	\$5,055.24	(\$1,668.23)	\$23,291.77	(\$120,210.86)
11	\$24,960.00	\$18,095.24	\$6,864.76	(\$2,265.37)	\$22,694.63	(\$97,516.23)
12	\$24,960.00	\$16,285.71	\$8,674.29	(\$2,862.51)	\$22,097.49	(\$75,418.74)
13	\$24,960.00	\$14,476.19	\$10,483.81	(\$3,459.66)	\$21,500.34	(\$53,918.40)
14	\$24,960.00	\$12,666.67	\$12,293.33	(\$4,056.80)	\$20,903.20	(\$33,015.20)
15	\$24,960.00	\$10,857.14	\$14,102.86	(\$4,653.94)	\$20,306.06	(\$12,709.14)
16	\$24,960.00	\$9,047.62	\$15,912.38	(\$5,251.09)	\$19,708.91	\$6,999.77
17	\$24,960.00	\$7,238.10	\$17,721.90	(\$5,848.23)	\$19,111.77	\$26,111.54
18	\$24,960.00	\$5,428.57	\$19,531.43	(\$6,445.37)	\$18,514.63	\$44,626.17
19	\$24,960.00	\$3,619.05	\$21,340.95	(\$7,042.51)	\$17,917.49	\$62,543.66
20	\$24,960.00	\$1,809.52	\$23,150.48	(\$7,639.66)	\$17,320.34	\$79,864.00
\$380,000.00						
Payback Period= 15.6 years						

source: Study Team

**Table VIII-7
PAYBACK ANALYSIS, ALTERNATIVE #2**

Initial Investment=\$470,000.00						
# Depreciating Years: 20					20	
Increase in Annual Income=\$39,120.00						
Note: 48 rail car loads received per year.						
Year	Before Tax Cash Flow	Depreciation (Sum-of-Digits)	Taxable Income	Income Tax 33.00%	After Tax Cash Flow	Cumulative Cash Flow
0	(\$470,000.00)	-	-	-	-	-
1	\$39,120.00	\$44,761.90	(\$5,641.90)	\$1,861.83	\$40,981.83	(\$429,018.17)
2	\$39,120.00	\$42,523.81	(\$3,403.81)	\$1,123.26	\$40,243.26	(\$388,774.91)
3	\$39,120.00	\$40,285.71	(\$1,165.71)	\$384.69	\$39,504.69	(\$349,270.23)
4	\$39,120.00	\$38,047.62	\$1,072.38	(\$353.89)	\$38,766.11	(\$310,504.11)
5	\$39,120.00	\$35,809.52	\$3,310.48	(\$1,092.46)	\$38,027.54	(\$272,476.57)
6	\$39,120.00	\$33,571.43	\$5,548.57	(\$1,831.03)	\$37,288.97	(\$235,187.60)
7	\$39,120.00	\$31,333.33	\$7,786.67	(\$2,569.60)	\$36,550.40	(\$198,637.20)
8	\$39,120.00	\$29,095.24	\$10,024.76	(\$3,308.17)	\$35,811.83	(\$162,825.37)
9	\$39,120.00	\$26,857.14	\$12,262.86	(\$4,046.74)	\$35,073.26	(\$127,752.11)
10	\$39,120.00	\$24,619.05	\$14,500.95	(\$4,785.31)	\$34,334.69	(\$93,417.43)
11	\$39,120.00	\$22,380.95	\$16,739.05	(\$5,523.89)	\$33,596.11	(\$59,821.31)
12	\$39,120.00	\$20,142.86	\$18,977.14	(\$6,262.46)	\$32,857.54	(\$26,963.77)
13	\$39,120.00	\$17,904.76	\$21,215.24	(\$7,001.03)	\$32,118.97	\$5,155.20
14	\$39,120.00	\$15,666.67	\$23,453.33	(\$7,739.60)	\$31,380.40	\$36,535.60
15	\$39,120.00	\$13,428.57	\$25,691.43	(\$8,478.17)	\$30,641.83	\$67,177.43
16	\$39,120.00	\$11,190.48	\$27,929.52	(\$9,216.74)	\$29,903.26	\$97,080.69
17	\$39,120.00	\$8,952.38	\$30,167.62	(\$9,955.31)	\$29,164.69	\$126,245.37
18	\$39,120.00	\$6,714.29	\$32,405.71	(\$10,693.89)	\$28,426.11	\$154,671.49
19	\$39,120.00	\$4,476.19	\$34,643.81	(\$11,432.46)	\$27,687.54	\$182,359.03
20	\$39,120.00	\$2,238.10	\$36,881.90	(\$12,171.03)	\$26,948.97	\$209,308.00
		\$470,000.00				
Payback Period= 12.8 years						

source: Study Team

EQUIVALENT UNIFORM ANNUAL COST (EUAC)

The equivalent uniform annual cost analysis is used to derive figures that represent the annual operating cost of the system if retired in the year "n". These figures are generated by determining the uniform annual recovery cost of the initial capital expenditure minus the annual salvage value plus the uniform annual cost of maintenance in the year "n". These uniform annual costs are generated by utilizing the capital recovery factor and the arithmetic gradient to uniform series factor. In Tables VIII-8 and

VIII-9, the "Total EUAC" column represents the uniform annual cost (capital recovery plus maintenance) if the project was terminated in the year "n".

Tables VIII-8 and VIII-9 show the equivalent uniform annual costs associated with alternatives #1 and #2, respectively. It has been assumed for this analysis that the interest rate is 8% and that the annual salvage value is negligible. The maintenance costs for alternative #1 are zero for the first year and increase \$600 dollars per year, every year thereafter. The maintenance costs for alternative #2 are zero for the first year and increase \$400 dollars per year, every year thereafter. The initial investment costs for alternative #1 and #2 are \$380,000 and \$470,000, respectively.

Figure VIII-1 indicates that the annual cost is greater for alternative #2 when the project is retired in the year "n".

CONCLUSION

The results of the analysis in this case study indicate that alternative #2 is superior based on the payback and rate of return analyses. Alternative #2 will pay back the investment approximately 2.8 years earlier than alternative #1. Moreover, alternative #2 has a 2.05% higher rate of return than alternative #1. The results of the EUAC analysis seem reasonable since the annual cost of capital recovery of the initial investment is significantly higher for alternative #2 than alternative #1. However, the results of this EUAC analysis do not provide enough evidence to support the selection of alternative #1. Thus, as stated previously, this case study supports the selection of alternative #2.

This was a simplified analysis undertaken mainly to explain the economic analysis techniques. It is unlikely that a shipyard would decide to make a major capital investment that takes 15 years to pay back. However, it is possible that a thorough analysis of a shipyard's pipe and shapes handling system would produce a much shorter payback period and justify the expenditures.

**Table VIII-8
EQUIVALENT UNIFORM ANNUAL COST (EUAC)
ALTERNATIVE #1**

Initial Investment Cost= \$380,000						
Salvage Value= \$0.00						
Interest Rate= 8.00%						
If retired at end of year "n"						
Year	Interest Rate	Estimated Salvage Value, End of Year n	Estimated Maintenance Cost for Year	EUAC of Capital Recovery	EUAC of Maintenance	Total EUAC
n				$\$380,000(A/P, 8\%, n)$	$\$600(A/G, 8\%, n)$	
1	8.00%	\$0.00	\$0.00	\$410,400.00	\$0.00	\$410,400.00
2	8.00%	\$0.00	\$600.00	\$213,092.31	\$288.46	\$213,380.77
3	8.00%	\$0.00	\$1,200.00	\$147,452.74	\$569.25	\$148,021.98
4	8.00%	\$0.00	\$1,800.00	\$114,729.91	\$842.38	\$115,572.28
5	8.00%	\$0.00	\$2,400.00	\$95,173.45	\$1,107.88	\$96,281.34
6	8.00%	\$0.00	\$3,000.00	\$82,199.85	\$1,365.81	\$83,565.65
7	8.00%	\$0.00	\$3,600.00	\$72,987.51	\$1,616.20	\$74,603.71
8	8.00%	\$0.00	\$4,200.00	\$66,125.61	\$1,859.11	\$67,984.72
9	8.00%	\$0.00	\$4,800.00	\$60,830.29	\$2,094.62	\$62,924.91
10	8.00%	\$0.00	\$5,400.00	\$56,631.21	\$2,322.79	\$58,953.99
11	8.00%	\$0.00	\$6,000.00	\$53,229.01	\$2,543.70	\$55,772.71
12	8.00%	\$0.00	\$6,600.00	\$50,424.11	\$2,757.45	\$53,181.55
13	8.00%	\$0.00	\$7,200.00	\$48,078.29	\$2,964.12	\$51,042.41
14	8.00%	\$0.00	\$7,800.00	\$46,092.80	\$3,163.83	\$49,256.63
15	8.00%	\$0.00	\$8,400.00	\$44,395.23	\$3,356.68	\$47,751.90
16	8.00%	\$0.00	\$9,000.00	\$42,931.21	\$3,542.78	\$46,473.99
17	8.00%	\$0.00	\$9,600.00	\$41,659.18	\$3,722.25	\$45,381.43
18	8.00%	\$0.00	\$10,200.00	\$40,546.80	\$3,895.22	\$44,442.01
19	8.00%	\$0.00	\$10,800.00	\$39,568.50	\$4,061.81	\$43,630.31
20	8.00%	\$0.00	\$11,400.00	\$38,703.84	\$4,222.17	\$42,926.01

source: Study Team

Table VIII-9
EQUIVALENT UNIFORM ANNUAL COST (EUAC)
ALTERNATIVE #2

Initial Investment Cost= \$470,000						
Salvage Value= \$0.00						
Interest Rate= 8.00%						
If retired at end of year n						
Year	Interest Rate	Estimated Salvage Value, End of Year n	Estimated Maintenance Cost for Year	EUAC of Capital Recovery	EUAC of Maintenance	Total EUAC
n				$\$470,000(A/P,8\%,n)$	$\$400(A/G,8\%,n)$	
1	8.00%	\$0.00	\$0.00	\$507,600.00	\$0.00	\$507,600.00
2	8.00%	\$0.00	\$400.00	\$263,561.54	\$192.31	\$263,753.85
3	8.00%	\$0.00	\$800.00	\$182,375.75	\$379.50	\$182,755.25
4	8.00%	\$0.00	\$1,200.00	\$141,902.78	\$561.58	\$142,464.36
5	8.00%	\$0.00	\$1,600.00	\$117,714.53	\$738.59	\$118,453.12
6	8.00%	\$0.00	\$2,000.00	\$101,668.23	\$910.54	\$102,578.77
7	8.00%	\$0.00	\$2,400.00	\$90,274.03	\$1,077.47	\$91,351.49
8	8.00%	\$0.00	\$2,800.00	\$81,786.94	\$1,239.41	\$83,026.35
9	8.00%	\$0.00	\$3,200.00	\$75,237.46	\$1,396.41	\$76,633.88
10	8.00%	\$0.00	\$3,600.00	\$70,043.86	\$1,548.53	\$71,592.39
11	8.00%	\$0.00	\$4,000.00	\$65,835.88	\$1,695.80	\$67,531.68
12	8.00%	\$0.00	\$4,400.00	\$62,366.66	\$1,838.30	\$64,204.96
13	8.00%	\$0.00	\$4,800.00	\$59,465.25	\$1,976.08	\$61,441.33
14	8.00%	\$0.00	\$5,200.00	\$57,009.52	\$2,109.22	\$59,118.74
15	8.00%	\$0.00	\$5,600.00	\$54,909.89	\$2,237.78	\$57,147.67
16	8.00%	\$0.00	\$6,000.00	\$53,099.13	\$2,361.85	\$55,460.98
17	8.00%	\$0.00	\$6,400.00	\$51,525.83	\$2,481.50	\$54,007.33
18	8.00%	\$0.00	\$6,800.00	\$50,149.99	\$2,596.81	\$52,746.80
19	8.00%	\$0.00	\$7,200.00	\$48,939.98	\$2,707.88	\$51,647.86
20	8.00%	\$0.00	\$7,600.00	\$47,870.54	\$2,814.78	\$50,685.32

source: Study Team

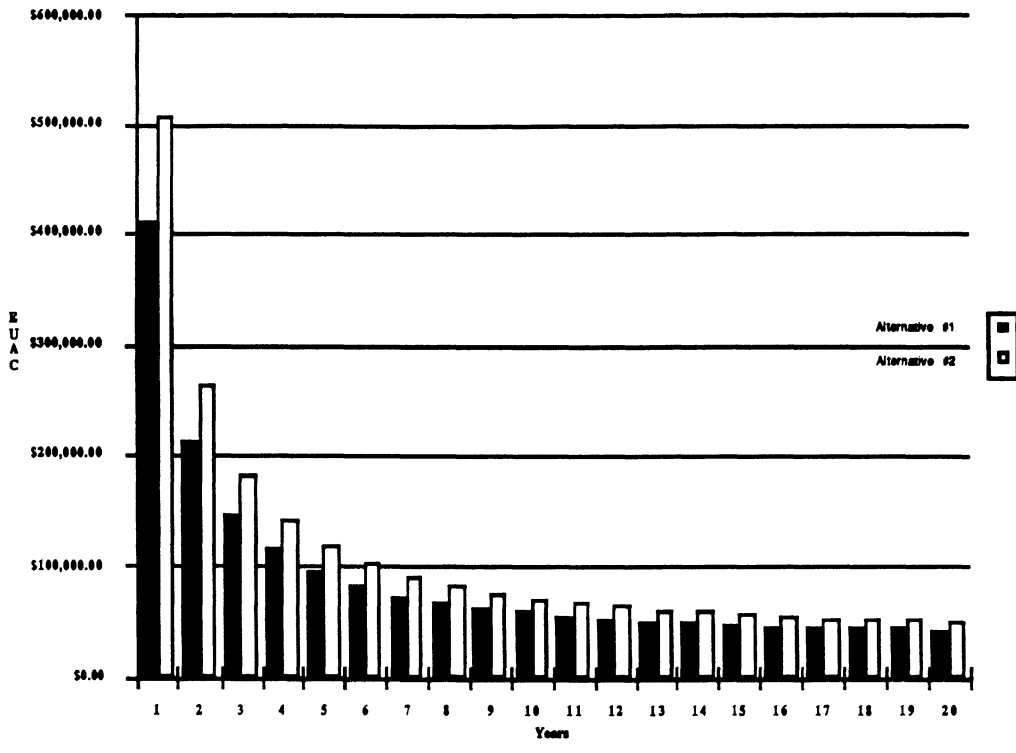

source: Study Team.

Figure VIII-1
TOTAL EUAC COMPARISON

IX. SUMMARY

The object of the research conducted for this report was to investigate efficient means for moving and storing pipe and shapes. The subject has frequently been referred to as a handling problem because there is no value added to the materials from handling alone.

Original plans were to develop an "ideal" system for this handling problem, but there are too many variables involved with the materials and the sizes of shipyards to label any one system ideal. However, various possible types and arrangements of moving and storing equipment have been described. In addition, methods and data by which the manager of the handling department in any shipyard could analyze his or her own situation have been presented to use as a framework for that analysis.

Thus, the objective of this report was to provide a shipyard industrial engineer with a reference and a framework by which to design and analyze movement and storage methods for pipe and shapes.

The sections that can be considered as references are Section II, "Review of Previous Studies and Literature", Section IV, "Principles of Material Handling", and Section VI, "Analysis of Movement and Storage Methods".

The "Review of Previous Studies and Literature" section evaluated many of the previous NSRP reports and other literature to develop the background for this study. This review also served to provide an additional reference source when analyzing pipe and shapes in the marine construction industry.

The "Principles of Material Handling" section discussed general material handling principles. These principles were introduced to provide guidelines for all the individuals involved in the design and analysis of existing and alternative systems.

The "Analysis of Movement and Storage Methods" section described the attributes of the various types of movement and storage devices with respect to handling pipe and shapes. Fork trucks, straddle carriers, lifter loaders, cranes and other machines were investigated along with specialty accessories to these pieces of equipment. Storage arrangements such as cantilever racks, pallet racks and stacks were also described in this section.

The sections that provided a framework for analysis were Section III, "Problem Definition", Section VII, "Material Handling System Design", and Section VIII, "Case Study".

The "Problem Definition" section defined problems involved with material handling in general, and movement and storage of pipe and shapes in particular. This section also summarized the particularly applicable findings of the literature search.

The "Material Handling System Design" section implemented the information developed in the previous sections. A "generic" shipyard was developed to serve as a basis for any shipyard material manager analyzing the movement and storage needs for their shipyard. A methodology was described for analyzing generic material handling problems, but concentrating on pipe and shapes handling. The body of this section described the methodology while a specific case study was presented in Section VIII.

In the "Case Study" section, a labor cost analysis was performed, with the aid of tools such as Flow Process Charts, From-To Charts, and Shipyard Layout Charts. All of these charts were discussed in a general sense, in the "Material Handling System Design" section. Specific numerical examples of these charts were not incorporated into the case study for simplicity. However, numerical information that was included in this case study began with the labor cost analysis and capital acquisition and operation costs for two alternatives. These two alternatives were compared based on engineering economic analysis techniques. The analysis techniques used were After Tax Rate of Return Analysis (ROR), Payback Analysis, Equivalent Uniform Annual Cost Analysis (EUAC). Based on these analyses, a superior alternative was selected.

The best handling system is not to have one at all. The ideal system would have the supplier deliver the needed items at the right place at the right time with reliable service. However, ours is not an ideal world, the supplier base in this country is not geared to just-in-time delivery, and such a delivery system would make the raw materials cost considerably more.

Therefore, the person making decisions on a material handling system must choose the most cost effective balance between economic order quantities, raw material handling and processing, and delivery of these materials to the customer, the pipe shop or fabrication shop using the materials.

REFERENCES

1. "Advanced Pipe Technology - Executive Summary." Newport News Shipbuilding, April 1977, NSRP 0065¹.
2. "Advanced Pipe Technology - Interim Report." Newport News Shipbuilding , April 1976 NSRP 0055.
3. "Automatic Painting of Structural Steel Shapes." General Dynamics/Quincy, 1974 NSRP 0034.
4. Baccara, Guido, Aldo Toso and Paolo Maschio, "Automation of Design and Production of Piping Systems" IREAPS 2nd Annual Symposium, 1975 NSRP 0001, Paper 22.
5. Bruce, G. J., "Materials Handling in Shipbuilding - Future Directions " Royal Institute of Naval Architects 1987.
6. Eastman, Robert M., Material Handling, Marcel Dekker, Inc., 1987.
7. "Feasibility Study of Semi-Automatic Pipe Handling System and Fabrication Facility" Avondale Shipyards Inc., NSRP 0074, 1978.
8. "Fitting and Welding Cylinders." Rogendorf/Avondale, NSRP 0208, May 1985.
9. Huber, Robert F. "Think of It as Flow." Production, Vol 100, No. 6, June 1988.
10. Kolodziejczak, Gregory C. "Group Technology Applications in Shipboard Piping System Manufacture." Masters Thesis, Massachusetts Institute of Technology 1985.
11. Kulwiec, Raymond A. "Advanced Material Handling." Material Handling Institute, 1983.
12. Kulwiec, Raymond A. "Basics of Material Handling" Material Handling Institute, 1981.
13. "Material Handling Equipment Study." Ingalls Shipbuilding, 1973 NSRP 0035.
14. "MOST Work Management Manual - Material Handling for Shipyards." Bethlehem Steel, Jul 1983 NSRP 0172.
15. "MOST Work Management Manual-Panel Assembly Platen Area." National Steel and Shipbuilding Company, Sept 1980 NSRP 0115.
16. "MOST Work Management Manual-Panel Line." National Steel and Shipbuilding Company, May 1980, NSRP 0103.
17. "MOST Work Management Manual-Pipe Fabrication Shop." Peterson Builders Inc. Jan 1981, NSRP 0123.
18. "MOST Work Management Manual - Temporary Staging for Shipyards." Bethlehem Steel, NSRP 0189, Jul 1983.

¹National Shipbuilding Research Program (NSRP) numbers refer to publications of the National Shipbuilding Research Program Bibliography of Publications and are available through The University of Michigan Transportation Research Institute, Marine Systems Division.

19. Nakanishi. "Development of Billet Handling System With Special Handling Machine and Rack." Transactions of the Iron and Steel Institute of Japan, 1985.
20. "Pipe Movement and Storage Study." Avondale Shipyards Inc., Feb 1986 NSRP 0230.
21. "Pipe Piece Family Manufacturing." Ishikawajima-Harima Heavy Industries (IHD) International for Todd Pacific Shipyards, Mar 1982, NSRP 0147.
22. "Product Oriented Material Management." Ishikawajima-Harima Heavy Industries (IHD) International for Todd Pacific Shipyards, Jun 1985, NSRP 0210.
23. "Requirements Report: Computer Software System for a Semi-Automatic Pipe Handling System and Fabrication Facility." IBM/Avondale Shipyards Inc., May 1980, NSRP 0106.
24. "Report On Moving Personnel and Light Material Onto a Ship and About A Shipyards." Leawood/Avondale, Nov 1985, NSRP 0231.
25. Saginaw, David J. "Implementation of an Integrated Fabrication Control Philosophy in a Modernized Shipyards Pipe Shop." Journal of Ship Production, Feb, 1986, Vol. 2, No. 1, .
26. "Semi-Automatic Beam Line Feasibility Study." Avondale Shipyards Inc., Nov 1981, NSRP 0135.
27. "Semi-Automatic Pipe Handling System and Fabrication Facility Phase II, Implementation" Avondale Shipyards Inc., Mar 1983, NSRP 0167.
28. "Special Structural Shapes: Factors Affecting Usage in U.S. Shipbuilding." Stanford Research Institute for Todd Pacific Shipyards Corp., Jul 1979 NSRP 0090.
29. Storch, Richard L., "Simulation Models for Development of Optimal Material Handling." National Steel and Shipbuilding Company, Sept 1989, NSRP 0305.
30. Sullivan, Daniel J. "Trends in Material Handling." 1989 Society of Manufacturing Engineers International Conference and Exposition, May, 1989.
31. Walstad, D.E., and D.W. Crawford, "The Importance of Correct Running and Handling Procedures for Premium Tubular Goods." Drilling Engineering December, 1988, Vol. 3, No. 4, .
32. Wilkens, Gunter. "Increase of Productivity by Automated Prefabrication of Pipe Spools." IREAPS 10th Annual Symposium, 1983, Paper 12, NSRP 0010.

XI. APPENDIX

MEMBER	REPRESENTATIVES			
	BOARD REPRESENTATIVE	DESIGNATED ENGINEER	STATISTICIAN	ATTORNEY
<p>TCM - continued</p> <p>CANADA</p> <p>Deval Handling Equipment 5630 Rue Bois-Franc Ville-St. Laurent Quebec, H4S 1A9</p> <p>(514) 332-3750</p> <p>FAX (514) 332-5249</p> <p>USA</p> <p>C. Itoh Ind. Machinery 7950 Blankenship Houston, TX 77055</p> <p>(713) 681-8888</p> <p>FAX (713) 681-8899</p> <p>TCM America P.O. Box 429 Killdeer Court Bridgeport, NJ 08014</p> <p>(609) 467-3200</p> <p>FAX (609) 467-5235</p>	<p>Rene Couture</p> <p>H. L. Bickford (V.P. Marketing)</p> <p>Steven Duce (Vice-President)</p>	<p>Thomas Grau (Service Engineer)</p>	<p>Doris Holland</p> <p>Gerald Melancon (Mgr. Supplier Admin.)</p> <p>Barbara Smith (Sales Coordinator)</p>	
<p>TOYOSHIMA SPECIAL STEEL USA</p> <p>735 St. Paul Street Indianapolis, IN 46203</p> <p>(317) 638-3511</p> <p>FAX (317) 631-7729</p>	<p>Yoshikazu Tanabe</p> <p>Alt. Satoshi Osanai</p>	<p>Yoshikazu Tanabe</p> <p>Jack Levine</p>		
<p>TOYOTA</p> <p>JAPAN</p> <p>Toyota Motor Corp. 23-22 Izumi 1-Chome Higashi-ku Nagoya 461</p> <p>052-952-2111</p>	<p>M. Toyoda</p>			

MEMBER	REPRESENTATIVES			
	BOARD REPRESENTATIVE	DESIGNATED ENGINEER	STATISTICIAN	ATTORNEY
THE RAYMOND CORPORATION P.O. Box 130 South Canal Street Greene, NY 13778 (607) 656-2311 FAX (607) 656-9005 Station Square 45 Lewis St. Binghamton, NY 13901 (607) 771-8097 FAX (607) 771-0782	Ross Colquhoun (President/CEO) Alt. George G. Raymond (Chairman of the Board)	Robert Rogers (Eng. Manager)	Cindy Dudra Ret Fenton	Paul Sternberg
SEVCON, INC. 40 North Avenue Burlington, MA 01803 (617) 272-3612 FAX (617) 272-1953	J. Brian Lamb (General Manager)	Christian Peyla (Engineer/ Oper. Mgr.)	Ann LeBourdais	
STEEL OF WEST VIRGINIA, INC. P.O. Box 2547 Huntington, WV 25726 (304) 696-8200 FAX (304) 529-1479	Robert Bunting (President) Alt. Michael Smith	Joseph D. Schweitzer (Chief Engr.) Tim Jenkins		
SWING SHIFT MFG. INC. 26709 N.W. 19th Ridgefield, WA 98642 (206) 887-4666 FAX (206) 887-3822	William A. Corn (CEO) Alt. Wayne Bostad (President)			
TCM JAPAN Toyo Umpanki Co. Ltd. TCM Building 1-15-5, Nishi-Shimbashi, Minato-ku, Tokyo 105 03-10-591-0551 FAX 33-591-8152	M. Takahashi			

MEMBER	REPRESENTATIVES			
	BOARD REPRESENTATIVE	DESIGNATED ENGINEER	STATISTICIAN	ATTORNEY
NISSAN JAPAN 17-1 Ginza 6-Chome Chuo-ku, Tokyo 81-03-543-5523 CANADA Nissan Industrial Division 5290 Orbitor Drive Mississauga Ontario L4W 4Z5 (416) 629-2888 FAX (416) 629-9710 USA 425 N. Martingale Road, Suite 1900 Schaumburg, IL 60173 (708) 706-3900 FAX (708) 706-3972	Kiichiro Tanaka (Managing Director) David A. Gordon (Director, Indus. Division) Alt. A. Ross Liddell Gerry Kirkland (General Mgr.)	Orval Wiens Bill Strain (Applications Engineer)	Lesley Carmichael Hank Unck (Sales Develop. Mgr.) Alt. Sue Nystrom	
PRESTOLITE ELECTRIC INC. Four Seagate Toledo, OH 43691 (419) 249-7600 FAX (419) 249-7637	Thomas R. Jennett	Jim A. Kier	Shirley J. DeGregorio	Jon Kubiak
THE PRIME MOVER COMPANY 3000 North Highway 61 Muscatine, IA 52761 (319) 262-7700 FAX (319) 262-7600 CANADA BT Canada Ltd 195 Royal Crest Ct. Ontario L3R 9X6 (416) 475-6150 FAX (416) 475-8605	Stephen Mullarkey (President)	Allen Trego (Chief Engr.) Alt. Lars Eriksson	Elaine Reid Laura Gaudet	

MEMBER	REPRESENTATIVES			
	BOARD REPRESENTATIVE	DESIGNATED ENGINEER	STATISTICIAN	ATTORNEY
KURDZIEL INDUSTRIES 2625 Winston Rd. Rothbury, MI 49452 (616) 893-1415 FAX (616) 894-4697	Joseph Kurdziel (President)			
LONG REACH MFG. P.O. Box 45069 Houston, TX 77245 (713) 433-9861 FAX (713) 433-9710	Mike Buchanan (President) Alt. E. J. Crosson	Carl A. Morris (Mgr. Research & Development)		
MITSUBISHI HEAVY INDUS. JAPAN Mitsubishi Corp. 6-3 Maronouchi Z-Chome Chiyoda-ku Tokyo 100 CANADA M. Lift Industrial Equipment 7559 M. B. Jodoin Anjou, Quebec H1J 2H9 (514) 354-8205 FAX (514) 354-4187 USA Machinery Distribution, Inc. 2011 W. Sam Houston Parkway, North Houston, TX 77043 (713) 467-1234 FAX (713) 467-3232	T. Matsuda Claude Dubois		Nicole Pelletier	
MULTITON MIC CORP. 4200 Oakleys Court Richmond, VA 23223 (804) 737-7400 FAX (804) 737-9050	Dirk von Holt (President)	Ted Argiros (Production Mgr.)	Andrew Krenitz (Operations Mgr.)	

MEMBER	REPRESENTATIVES			
	BOARD REPRESENTATIVE	DESIGNATED ENGINEER	STATISTICIAN	ATTORNEY
KALMAR AC HANDLING SYSTEMS, INC. 777 Manor Park Dr. Columbus, OH 43228 (614) 878-0885 FAX (614) 878-0942	Bengt Ljung (President) Alt. Bruce Bowman (V.P. Parts & Services) Jeff Smith (V.P. Sales & Marketing)		Lynette Wilcox	
KENHAR PRODUCTS, INC. P.O. Box 1508 Guelph, Ontario Canada N1H 6N9 (519) 763-3675 FAX (519) 763-4714	William Harrison (President & CEO) Alt. Les Whittle (Mgr. Customer Service) R. D. Varilek (Mgr. Marketing)	W. J. Harrison R. D. Varilek F. K. Blazik	W. J. Harrison R. D. Varilek	
KOMATSU FORKLIFT INC. JAPAN No. 3-4 Akasaka 2-Chome, Minato-ku Tokyo 107 (03) 586-5111 CANADA Komastu Co. Ltd. 1725 Sismet Rd. Mississauga, Ontario L4W 1P9 (416) 625-6292 FAX (416) 625-6348	Munenobu Yamada (President) Dave Meades (Mgr. Forklift Division)	Des Gallant (Product Support Mgr.)	Debbie July (Marketing Secretary, Forklift Div.)	
USA 14815 Firestone Blvd. La Mirada, CA 90638 (213) 802-1312 FAX (714) 670-0229	Akira Otsuka (Exec. V.P., General Mgr.) Alt. Michael Howlett (V.P. Sales Administration)	Jeff Powell (Nat. Service Mgr.) Henry Shina (Mgr. of Product Support)	Linda Vermey Eiji Ogawa	

MEMBER	REPRESENTATIVES			
	BOARD REPRESENTATIVE	DESIGNATED ENGINEER	STATISTICIAN	ATTORNEY
HERCULES ENGINES, INC. 101 Eleventh St. S.E. Canton, OH 44707 (216) 454-5631 FAX (216) 438-1313	Gary R. Smith (President) Alt. Robert Holtgrieve (Senior V.P.)	Paul Cassidy (V.P. Eng.)	Kim Boyer (Dir. Sales Admin.)	
HYSTER COMPANY 1901 E. Voorhees St. P.O. Box 847 (61834) Danville, IL 61832 (217) 443-7000 FAX (217) 443-7396 P.O. Box 2902 (97208) 2701 N.W. Vaughn Suite 900 Portland, OR 97210 (503) 721-6000 FAX (503) 721-6001	Stephen Finney (V.P. Sales) Alt. Frank Schafer (Gen. Mgr. Mktg. Services)	Gary Gaulke (Dir. Product Assurance) Alt. Ronald Leptich (V.P. Eng.)	Carol Milner	Bergen Bull (Legal Officer/ Secretary)
INDUSTRIAL TIRES LTD. 3161 Wharton Way N. Mississauga, Ontario Canada L4X 2B7 (416) 625-1600 FAX (416) 625-1277	T. P. Buckley (President) Alt. T. A. Buckley	Alistair Cowe		
K-D MANITOU, INC. 8120 Gholson Rd. P.O. Box 4547 Waco, TX 76705 (817) 799-0232 FAX (817) 799-4433	Serge Bosche (Exec. V.P.) Alt. Frank Aucoin (Sales Manager)	John Gibel (Mgr. Eng.)	Lesa Irwin (Sales Coordinator)	
K W Battery 3555 Howard St. Skokie, IL 60076 (708) 982-9060 FAX (708) 675-4410	Thomas Murphy (V.P. Marketing)	Thomas Murphy		

MEMBER	REPRESENTATIVES			
	BOARD REPRESENTATIVE	DESIGNATED ENGINEER	STATISTICIAN	ATTORNEY
EAST PENN MFG. CO. INC. Deka Road Lyon Station, PA 19536 (215) 682-6361 FAX (215) 682-4781	Evan R. Wescoe (V.P. Sales Ind. Motive Power, Mining, Railroad) Alt. R. P. Bowers	Martin Stanton (Mgr. Battery Systems & App. Engineering) Andrew Dietrich	Arlan Schroeder	
ELWELL-PARKER ELECTRIC COMPANY 4205 St. Clair Ave. Cleveland, OH 44103 (216) 881-6200 FAX (216) 391-7708	Sheldon K. Towson, Jr. (Pres. & Chairman) Alt. Charles Herron (Mgr. Engineering)	Charles Herron	David Stankiewicz (Int'l. Sales Manager)	
ENGELHARD CORPORATION 101 Wood Avenue Edison, NJ 08818 (908) 205-7235 FAX (908) 205-6146	Rich Gay (Commercial Mgr.) Alt. Al Kinal (Regional Sales)	Rich Gay		
ERECTOWELD CO. LTD. Forged Forks Div. 740 Weller Court Oakville, Ontario Canada L6K 3S9 (416) 338-6688 FAX (416) 338-6697	Francis J. Walsh (Secretary- Treasurer) Alt. Elmer Mann (Div. Manager)	Francis J. Walsh		
EXIDE CORPORATION 645 Penn Street Reading, PA 19601 (215) 378-0500 FAX (215) 378-0616	Ray J. Kenny Alt. Michael Buggy	Ira Baeringer (V.P. Eng.)	Bob Grace (Dir. Operations) Jeff Goss	
GNB INDUSTRIAL BATTERY COMPANY 829 Parkview Blvd. Lombard, IL 60148 (708) 629-5200 FAX (708) 691-7808	Kevin Leary (Gen. Mktg. & Sales Mgr.) Alt. Doug Bouquard	Doug Bouquard	Khris Dockendorf	

MEMBER	REPRESENTATIVES			
	BOARD REPRESENTATIVE	DESIGNATED ENGINEER	STATISTICIAN	ATTORNEY
CLARK MATERIAL HANDLING COMPANY 333 W. Vine Street Lexington, KY 40507 (606) 288-1200 FAX (606) 288-1324 Security Trust Bldg. 106 W. Vine Street Suite 701 Lexington, KY 40507 (606) 288-1352 FAX (606) 288-1355	James B. Bennett (V.P. Sales) Alt. Thomas C. Hoying (Gen. Mgr. Dealer Sales)	Tom Hill James Schell (Consultant)	Lee Ann Merritt	Mike Grossman
CROWN EQUIPMENT 40 S. Washington St. New Bremen, OH 45869 (419) 629-2311 FAX (419) 629-3796	James Moran (V.P. Marketing) Alt. Thomas C. Hoying (Gen. Mgr. Dealer Sales)	Dan Dunlap	Kathy Topp	John G. Maxa Denny Montgomery
CURTIS INSTRUMENTS, INC. 200 Kisco Ave. Mt. Kisco, NY 10549 (914) 666-2971 FAX (914) 666-2188	Erland Hagman (V.P. Marketing) Alt. Edward Marwell (President)	Eugene Finger (V.P. Eng.)		
DREXEL INDUSTRIES, INC. Maple Avenue P.O. Box 248 Horsham, PA 19044 (215) 672-2200 FAX (215) 672-0690	Ned Ramm (Mgr. Contracts/ Sales) Alt. Skip Russo (President)	George Androscopic (Project Engineer) Ned Ramm	Cathy Kenvin (Sales Coordinator) R. Kraus (Mgr. Product Support)	Ned Ramm

MEMBER	REPRESENTATIVES			
	BOARD REPRESENTATIVE	DESIGNATED ENGINEER	STATISTICIAN	ATTORNEY
C & D POWER SYSTEMS 3043 Walton Road Plymouth Meeting, PA 19462 (215) 828-9000 FAX (215) 834-7306	Robert A. Zinni (Mgr. Inside Sales Services)	Franz Wagner (Mgr. Battery Design Eng.)	Robert A. Zinni	
CASCADE CORPORATION Parkside Center Suite 600 2020 S.W. 4th Ave. Portland, OR 97201 (503) 227-0024 FAX (503) 274-1705	R. C. Warren, Jr. (V.P. Marketing) Alt. Joseph J. Barclay (President)	Harry F. Weinert (V.P. Eng.) John E. Olson	R. C. Warren	Robert Kolar
CATERPILLAR INDUSTRIAL, INC. 5960 Heisley Road Mentor, OH 44060 (216) 357-2200 FAX (216) 357-4431 100 N. E. Adams* Peoria, IL 61629 (309) 675-5625 FAX (309) 675-6620	Richard A. Benson (President) Alt. Larry Wuench (Dir. N. American Mktg. Electric Products)	Larry Liljequist (Elec. Product Gen. Mgr.) Paul A. Reid (Staff Engineer)	Dennis Morgan (Market Research Mgr.) Lloyd Knapp (Dir. Business Service/Parts)	William C. Shannon* Curt Enyeart*
CHLORIDE/PILOT INDUSTRIAL BATTERIES CANADA 7480 Bath Road Mississauga, Ontario, L4T 1L2 (416) 677-8627 FAX (416) 677-7699 USA Rural Route 6 Box 124-A Kankakee, IL 60901 (815) 933-9407 FAX (815) 933-8297	Trevor Haarer Peter Wheeler (V.P. Sales/Mktg.) Alt. George Moon (V.P. Gen. Mgr.)	Roger Brekke		

MEMBER	REPRESENTATIVES			
	BOARD REPRESENTATIVE	DESIGNATED ENGINEER	STATISTICIAN	ATTORNEY
ANDERSON POWER PRODUCTS 145 Newton St. Boston, MA 02135 (617) 787-5880 FAX (617) 254-9217	David Friend (President) Alt. R. W. Conklin	Jack Becker		
AQUILA CORPORATION 4413 Singleton Blvd. Dallas, TX 75212 (214) 634-8100 FAX (214) 634-9450	Richard Grant (President, CEO)			
BAKER MATERIAL HANDLING P.O. Box 2400 Summerville, SC 29484 (803) 875-8000 FAX (803) 875-8329	Robert Crandell (V.P. Marketing)	Manfred Baumann (V.P. Engineering)	Robert Crandell Alt. Corey Lutynski	
BARRETT INDUSTRIAL TRUCKS, INC. 240 N. Prospect St. Marengo, IL 60152 (815) 568-6525 FAX (815) 568-8340	Larry Borre (V.P. Sales & Marketing) Alt. Yashuhiko Watanabe (President)	Gary Nakai (V.P. Electrical Products Eng.) George Maes (Director of Internal Comb. Products Eng.)	Kathy Atkinson	
BASILOID PRODUCTS CORP. 312 N. East Street Elnora, IN 47529 (812) 692-5511 FAX (812) 692-5512	James E. Wampler (Vice-President)	James E. Wampler		
BIG JOE MFG. INC. 7225 N. Kostner Ave. Lincolnwood, IL 60646 (708) 675-8700 FAX (708) 675-7204	Edward M. Horwich (Executive V.P.)	Lee Whittaker (Manager, Engineering)	Neta Pritzker (Executive Secretary)	



AUTOMATED STORAGE/RETRIEVAL SYSTEMS

MEMBERSHIP ROSTER AS OF NOVEMBER 30, 1989

<u>COMPANY</u>	<u>CONTACT</u>	<u>TELEPHONE #</u>
ACCO BABCOCK, INC. 127555 E. Nine Mile Rd. Warren, MI 48089	Richard Slade	313-755-7500 FAX # 313-755-7859
CLARK AUTOMATED SYSTEMS 333 West Vine Street Lexington, KY 40507-1640	John Jepsen	606-288-1200 FAX # 606-288-1226
CYBERNATED AUTOMATION CORP. 3561 N.W. 126th Avenue P. O. Box 8049 Coral Springs, FL 33065	Robert Osborne	305-755-3780 FAX # 305-755-3771
MANNESMANN-DEMAG CORP Material Handling Systems Div. 2660 28th Street, S.W. Grand Rapids, MI 49508	Howard Zollinger	616-957-0800 FAX # 616-957-2515
EATON-KENWAY P. O. Box 4250 515 East 100 South Salt Lake City, UT 84110	Steven Barlow	801-530-4000 FAX # 801-530-4243
HARNISCHFEGER CORPORATION P. O. Box 554 Milwaukee, WI 53201	J. Philip Winiger	414-671-4400 FAX # 414-797-6573
INTERLAKE Integrated Systems Group 4750 Wiley Post Road Suite 110 Salt Lake City, UT 84116-2878	James S. Petersen	801-538-0314 FAX # 801-538-0892
JERVIS B. WEBB COMPANY 34375 West 12 Mile Road Farmington Hills, MI 48018	Terrance E. Brod	313-553-1000 FAX # 313-553-1253 or 313-553-1000
LITTON IAS 5825 Oberlin Drive San Diego, CA 92121	J. Larry Harding	619-587-2303 FAX # 619-587-2483
LOGAN CO. Figgie International Co. P. O. Box 6107 Louisville, KY 40206	Ray Horrey	502-587-1361 FAX # 502-587-1503

-2-

AS/RS Member Roster

MUNCK AUTOMATION P. O. Box 6677 Newport News, VA 23606	Bradley J. Moore	804-838-6010 FAX # 804-826-5651
REPUBLIC STORAGE SYSTEMS 1038 Belden Avenue, N.E. Canton, OH 44705	Sam Miller	216-434-5800 FAX # 216-434-7771
STANLEY-VIDMAR, INC. 10603 Chester Road Cincinnati, OH 45215	Robert Goosman	513-772-3900 FAX # 513-772-3904
WEBB-TRIAK COMPANY Subsidiary of J. B. Webb Co. 215 Fifth Avenue Chardon, OH 44024	Harry Smith	216-285-4630 FAX # 216-285-1878

CONVEYOR SECTION

The Material Handling Institute, Inc.



3720 Red Oak Blvd.
Suite 201
Charlotte, NC 28217
(704) 522-8644
FAX (704) 522-7826

Daniel Quinn - Product Section Chairman
Larry Frey - Product Section Vice-Chairman

Revised: 10-24-89

CONVEYOR PRODUCT SECTION ROSTER

ANCRA INTERNATIONAL
4880 West Rosecrans Avenue
Hawthorne, CA 90250
(213) 973-5000
FAX: 213/973-1138

* Ed Scott

THE E.W. BUSCHMAN COMPANY
10045 International Blvd.
Cincinnati, OH 45246
(513) 874-0788

* Lawrence D. Frey
** Gerald A. Fulkerson

ERMANCO, INC.
Subsidiary of Whiting Corporation
P.O. Box 241
Spring Lake, MI 49456
(616) 846-8420

* Lee Schomberg

HI-LINE STORAGE SYSTEMS CO.
P.O. Box 217
Hi-Line Drive & Ridge Road
Perkasie, PA 18944
(215) 257-3600

* Robert Egner
** Jeff Dickson

INTERLAKE, INC.
550 Warrenville Road
Lisle, IL 60532
(312) 852-8800

* Tim Bastic
** Ellsworth Collins

LANGLEY MANUFACTURING DIVISION
M.D. Knowlton Company
P.O. Box 29
Victor, NY 14565
(716) 924-3230

* Gerald Brace

MATERIAL HANDLING ENGINEERING
Penton Publishing Company
1100 Superior Avenue
Cleveland, OH 44114
(216) 696-7000

* Bernie Knill
** George Horrigan

MODERN MATERIALS HANDLING

Cahners Publishing Company

275 Washington Street
Newton, MA 02158-1630
(617) 558-4374 (Sbordon)
(617) 558-4217 (Kulwicz)

* William G. Sbordon
** Raymond Kulwicz

NORFOLK CONVEYOR DIVISION

Jervis B. Webb Company

155 King Street
Cohasset, MA 02025
(617) 383-9400

* Robert H. Roth
*** Robert E. Kohl

RAPISTAN CORPORATION

507 Plymouth Avenue, N.E.
Grand Rapids, MI 49505
(616) 451-6200

* John Raab

SOUTHWORTH, INC.

P.O. Box 1380
Portland, ME 04104
(207) 772-0130

* Daniel J. Quinn

J. B. WEBB COMPANY

Webb Drive
Farmington Hills, MI 48018

* Bob Pierson
** Pat Pierson

- * Delegate
- ** Alternate
- *** Engineering Delegate

CRANE MANUFACTURERS' ASSOCIATION OF AMERICA, INC.
MEMBER COMPANIES

ABELL-HOWE COMPANY
7747 Van Buren Street
Forest Park, IL 60130
312/366-4800

BABCOCK INDUSTRIES, INC.
76 Acco Drive, Box 792
York, PA 17405
717/741-4863

AMERICAN CRANE & EQUIPMENT CORP.
605 Old Swede Road
Douglassville, PA 19518
215/385-6061

CRANE MANUFACTURING & SERVICE
6000 South Buckhorn Avenue
Cudahy, WI 53110
414/769-8162

DETROIT HOIST & CRANE COMPANY
Post Office Box 686
Warren, MI 48090
313/268-2600

EDERER INCORPORATED
2925 1st Avenue South
Seattle, WA 98134
206/622-4421

HARNISCHFEGER CORPORATION
Post Office Box 310
Milwaukee, WI 53201
414/671-4400

HARRINGTON HOIST
401 West End Avenue
Manheim, PA 17545
717/665-2000

HECO PACIFIC MANUFACTURING, INC.
1510 Pacific Street
Union City, CA 94587
415/487-1155

KRANCO, INC.
10543 Fisher Road
Houston, TX 77041
713/466-7541

LANDEL, INC.
7300 Chippewa
Houston, Texas 77086
713/445-2225

LIFT-TECH INTERNATIONAL
Post Office Box 769
Muskegon, MI 49443
616/733-0821

MANNESMANN DEMAG CORP.
29201 Aurora Road
Solon, Ohio 44139
216/248-2400

NORTHERN ENGINEERING
210 Chene Street
Detroit, MI 48207
313/259-3280

PACECO, INC.
West Seaway Access Road
Calipport, MISS. 39503
601/896-1010

PHILADELPHIA TRAMRAIL
2207 East Ontario Street
Philadelphia, PA 19134
215/533-5100

SHEPARD NILES CORP.
North Genesee Street
Montour Falls, NY 14865
607/535-7111

STANSPEC CORPORATION
13600 Deise Avenue
Cleveland, Ohio 44110
216/451-9800

WHITING CORPORATION
15700 Lathrop Avenue
Harvey, IL 60426
312/331-4000

ZENAR CORPORATION
7301 South 6th Street
Oak Creek, WI 53154
414/764-1800

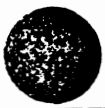

INDUSTRIAL METAL CONTAINERS

IMC Product Section Roster

E.G.A. Products Corporation (414) 781-7899
4275 North 127th Street FAX (414) 781-3586
P.O. Box 366
Brookfield, WI 53005
*Walter Young

Nashville Wire Products Mfg. Co. (615) 254-7716
1604 County Hospital Road FAX (615) 242-1089
Nashville, TN 37218
*Donald E. Schrader

Powell-Essco Products Company (317) 884-0613
PO Box 345 FAX (317) 884-0308
Fowler, IN 47944
*Thomas McIntee

Powell Pressed Steel Company (216) 759-9220
162 Churchill-Hubbard Road FAX (216) 759-9343
Youngstown, OH 44505
*William R. Powell

Richfield Iron Works, Inc. (313) 634-8267
4149 Grange Hall Road FAX (313) 634-2040
Holly, MI 48442 (Located in Flint Office)
*Howard Campbell

Sigma Industries (517) 857-2277
110 Willow Street
PO Box 288
Springport, MI 49284
*Stanley Jurasek

Steel King Industries, Inc. (715) 341-3120
2700 Chamber Street FAX (715) 314-8792
Steven Point, WI 54481
*Frederic Anderson
**Rob White

Union Steel Products Company (517) 629-2181
500 North Berrien Street FAX (517) 629-9009
Albion, MI 49224
*Leo Rogers
**Wallace Schermer

*Delegate
**Alternate

B4-1

PLASTICS PRODUCT SECTION
MEMBERSHIP ROSTER

AKRO MILS, INC.
1293 South Main Street
Akron, OH 44301
(216) 253-5592

BUCKHORN, INC.
55 W. Technecenter Drive
Milford, OH 45150
(513) 831-4402

COLVIN PACKAGING
1391 Hundley Street
Anaheim, CA 92806
(714) 630-3850

DOW CHEMICAL, U.S.A.
Plastic Department
433 Building
Midland, MI 48667
(517) 636-1000

GENERAL ELECTRIC PLASTICS
One Plastic Avenue
Pittsfield, MA 01201
(413) 448-7110

J.I.T. CORPORATION
18470 W. 10 Mile Rd.
Southfield, MI 48075-2615
(313) 559-8898

LEWISYSTEMS DIVISION
Menasha Corporation/Plastics Group
128 Hospital Drive
P. O. Box 508
Watertown, MI 53094
(414) 261-4030

LOUDON PLASTICS
787 Watervliet-Shaker Road
Latham, NY 12110
(518) 783-7776

MENASHA CORPORATION
Molded Products Division
426 Montgomery Street
Watertown, MI 53094
(414) 261-3162

MODERN MATERIALS HANDLING
275 Washington Street
Newton, MA 02158-1630
(617) 964-3030

MOLDED FIBER GLASS TRAY CO.
East Erle Street
Linesville, PA 16424
(814) 683-4500

SHELLER-GLOBE ENGINEERED POLYMERS
1020 East Maple
Moia, MN 55051
(612) 679-3232

XYTEC, INC.
P. O. Box 99057
9350 47th Avenue, SW
Tacoma, WA 98499-0057
(206) 582-0644

Revised: 7/5/89



RACK MANUFACTURERS INSTITUTE

RACK MANUFACTURERS INSTITUTE, INC.

MEMBERSHIP ROSTER AS OF NOV. 15, 1989

AMERICAN STEEL BUILDING

P. O. Box 14244
Houston, TX 77221
Telephone: 713-433-5661
Attention: Mr. Don Crider

APPLIED STORAGE KONCEPTS

13231 Lakeland Road
Santa Fe Springs, CA 90670
Telephone: 213-944-3202
Attention: Mr. Joel Arenson

ARTCO CORPORATION

Penn Avenue
Hatfield, PA 19440
Telephone: 215-723-6041
Attention: Ms. Ruth Morris

AUTO-LOK, INC.

4721 Lewis Road
Stone Mountain, GA 30083
Telephone: 404-934-1762
Attention: Mr. William Liberato

BASE MANUFACTURING

4950 South Royal Atlanta Drive
Tucker, GA 30084
Telephone: 404-938-2273
Attention: Mr. Bob Snipes

D'ALTRUI INDUSTRIES

685 U. S. Highway One, P. O. Box 902
Elizabeth, NJ 07202-0902
Telephone: 201-351-8900 or 1-800-524-2439
Attention: Mr. Alex Rivera

DYNABILT MATERIAL HANDLING DIVISION

Burtman Iron Works, Inc.
31 Industrial Drive, P. O. Box 5
Readville, MA 02137
Telephone: 617-364-1200
Attention: Mr. Earl Burtman

-2-

RMI Roster

ENGINEERED PRODUCTS CO.

P. O. Box 6767
Greenville, SC 29606
Telephone: 803-234-4888
Attention: Mr. William Griffith

EQUIPTO

225 South Highland
Aurora, IL 60507
Telephone: 312-859-1000
Attention: Mr. Michael O'Halloran

EUGENE WELDING

2420 Wills Street
Marysville, MI 48040
Telephone: 313-364-7421
Attention: Mr. Dave Weaver

FORT STEUBEN PRODUCTS

200 Fort Steuben Road
Weirton, WV 26062
Telephone: 800-362-9657
Attention: Mr. Stanley Caraher

FRAZIER INDUSTRIAL CO.

Box F
Long Valley, NJ 07853
Telephone: 201-876-3001
Attention: Mr. Carlos Oliver

FRICK-GALLAGHER MFG. CO.

330 South Ewing Street
P. O. Box 788
Lancaster, OH 43130
Telephone: 614-653-5700
Attention: Mr. Paul H. Frick, Jr.

HI-LINE STORAGE SYSTEMS CO.

Hi-Line Drive and Ridge Road
Perkosie, PA 18944
Telephone: 215-257-3601
Attention:

HUSKY STORAGE SYSTEMS

2101 Randall Road
Lithonia, GA 30058
Telephone: 404-482-4000
Attention: Mr. Ronald Young

RMI Roster

INCA METAL PRODUCTS CORP.

One Inca Place
P. O. Box 897
Lewisville, TX 75067
Telephone: 214-436-5581
Attention: Mr. Jerry Evatt

INTERLAKE, INC.

550 Warrenville Road
Lisle, IL 60521
Telephone: 312-719-7007
Attention: Mr. Daniel Wilson

LYON METAL PRODUCTS

P. O. Box 671
Aurora, IL 60506
Telephone: 219-872-7238
Attention: Mr. Bob Brady

MONARCH ROLLING, INC.

7201 W. Bradley Road
Milwaukee, WI 53223
Telephone: 312-352-5151
Attention: Mr. Joseph Huske

NESTAWAY

Axia, Inc.
9501 Granger Road
Cleveland, OH 44125
Telephone: 216-587-1500
Attention: Mr. Chris Deibel

PAR STEEL PRODUCTS

383 East 16th Street
Chicago Heights, IL 60411
Telephone: 312-758-5800
Attention: Mr. James Marshall

PENCO PRODUCTS

Brower Avenue
Oaks, PA 19456
Telephone: 215-666-0500
Attention: Mr. Charles Hohns

PREST STORAGE RACK

500 Innsbrook Lane
P. O. Box 703
Brookings, SD 57006
Telephone: 605-692-6990
Attention: Mr. George Prest

RMI Roster

REPUBLIC STORAGE SYSTEMS

1038 Belden Avenue
Canton, OH 44705
Telephone: 216-438-5800 or 800-321-0216
Attention: Mr. Don Durbin

RIDG-U-RACK, INC.

120 South Lake Street
North East, PA 16428
Telephone: 814-725-8751
Attention: Mr. John Pellegrino

SAMMONS & SONS

2911 Norton Avenue
Lynwood, CA 90262-0309
Telephone: 213-636-2488
Attention: Mr. John W. Beach

SPEEDRACK, INC.

5025 Arapaho Road - Suite 530
Dallas, TX 75248
Telephone: 214-991-0568
Attention: Mr. Phil Belisle

STEEL KING INDUSTRIES

2700 Chamber Street
Stevens Point, WI 54481
Telephone: 715-341-3120
Attention: Mr. Fred Anderson

TIER-RACK CORPORATION

818 Olive Street
St. Louis, MO 63110
Telephone: 314-231-5553
Attention: Mr. F. Anderew Bell

UNARCO MATERIAL STORAGE

332 South Michigan Avenue
Chicago, IL 60604
Telephone: 312-341-1234
Attention: Mr. Herb Klein

UNITED STEEL STORAGE, INC.

3775 Zip Industrial Blvd.
Atlanta, GA 30354
Telephone: 404-768-2428
Attention: Mr. Bill Lindler

JERVIS B. WEBB COMPANY

Webb Drive
Farmington Hills, MI 48018
Telephone: 313-553-1000
Attention: Thomas Wolsos

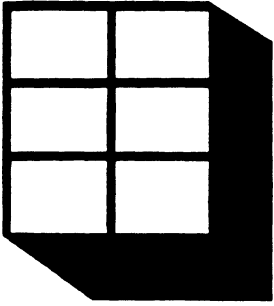

SHELVING MANUFACTURERS ASSOCIATION

PRODUCT SECTION OF M.H.I.

8720 Red Oak Blvd.
Suite 201
Charlotte, NC 28217
704/522-8644

SHELVING MANUFACTURERS ASSOC.

MEMBERSHIP ROSTER AS OF OCTOBER 1, 1989

Mr. S. T. Taylor, Jr
Adapto Steel Products
625 East 10th Avenue
P. O. Box 1660
Hialeash, FL 33011

Mr. Joel Arenson
Applied Storage Koncepts, Inc.
13231 Lakeland Road
Santa Fe Springs, CA 90670

Mr. Mike O'Halloran
Equipto
225 South Highland
Aurora, IL 60507

Mr. Ed Quintana
Inca Metal Products
One Inca Place
P. O. Box 897
Lewisville, TX 75067

Mr. James Ammons
Lyon Metal Products, Inc.
P. O. Box 671
Aurora, IL 60507

Mr. Charles Hohns
Penco Products
Brower Avenue
Oaks, PA 19456

Mr. Don Durbin
Republic Storage Systems Co.
1038 Belden Avenue
Canton, OH 44705

Mr. Richard Wright
Hallowell Industries, Inc.
Township Line Road
Hatfield, PA 19440

Mr. Robert Gray
American Metal Works, Inc.
Bay Products Division
8701 Torresdale Avenue
Philadelphia, PA 19136

Mr. Paul Frick, Jr.
Frick-Gallagher
330 South Ewing Street
P. O. Box 788
Lancaster, OH 43130

Mr. Dave Johnstone
Ft. Steuben Products
200 Fort Steuben Road
Weirton, WV 26062

Mr. Len Kowalski
Richards-Wilcox
174 Third Street
Aurora, IL 60507

Mr. Charles Jenny
Whitney Rand Mfg. Corp.
505 Ellison Place
Box 2121
Paterson, NJ 07509

Mr. Fred DeMaio
Tri-Boro Shelving & Partition
296 Wythe Avenue
Brooklyn, NY 11211

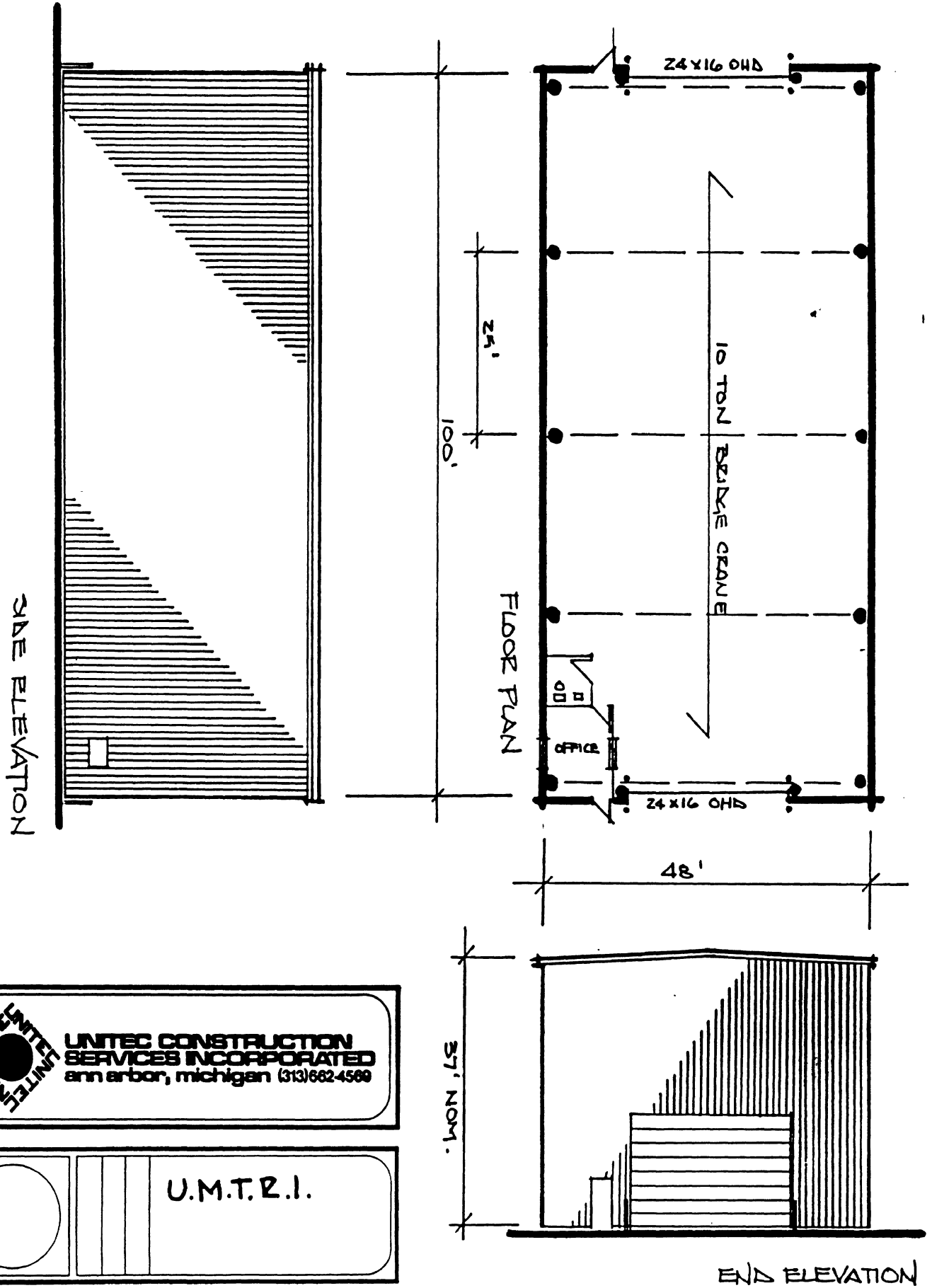

UNITEC CONSTRUCTION SERVICES INCORPORATED
ann arbor, michigan (313) 862-4589

U.M.T.R.I.

UNITEC CONSTRUCTION SERVICES INC.

411 Huron View Blvd., Ann Arbor, Mich. 48103

Phone (313) 662-4569 Fax (313) 662-3709

BALLPARK ESTIMATE SPREAD SHEET

The following prices are extrapolated from historical data and are not results of actual take offs. THESE FIGURES SHOULD BE USED FOR BUDGETING PURPOSES ONLY.

A = Indicates Allowance

PROJECT NAME:		<i>U.M.T.R.I. - Al Horseman</i>				PERCENT
DESCRIPTION:		Boat Parts Storage		COST		OF
Square Footage:		4800		PER		TOTAL
Date:		16-Oct-90		COST	SQ. FT.	PROJECT
1.00	Des/Gen Req/Supr	Design	A 3264	0.68		1.8%
	Civil and site engineering and drawings not included.					
	Architectural, mechanical, electrical, design and drawings.					
1.08	Permits		N.I.C.			
	General Requirements	A	4896	1.02		2.7%
	Layout, testing, barricades, temp utilities, site clean-up, etc.					
	Project Control (Super)	A	9791	2.04		5.4%
	On site supervision and project expediting.					
2.20	Site Development	Earthwork	A 2000	0.42		1.1%
	Strip 6" of topsoil and fill 6" of granular fill to 5' outside building line					
	Utilities	Gas/Elect	N.I.C.			
2.50	Underground	Wtr/San/St	N.I.C.			
2.60	Paving		N.I.C.			
3.00	Concrete	Foundation	A 10904	2.27		6.0%
	Assuming 3000psf soil capacity and no underground obstructions.					
		Flatwork	A 12280	2.56		6.8%
	6" steel reinforced slab					
	Exterior door pads and aprons					
5.00	Steel	Struct.	A 74697	15.56		41.2%
	Butler Widespan building					
	Butlerib roof system					
	Butlerib wall system					
	Gutters, and downspouts					
5.55		Erection	A 9600	2.00		5.3%
6.00	Wood and Plastic	Carpentry	A 2800	0.58		1.5%
	Stud and drywall partitions for office and toilet room					
	Mezzanine deck over office and toilet room					
	2x4 acoustical lay-in ceiling in office and toilet room					
7.20	Thermal/Moist	PEB Insul	N.I.C.			
8.10	Doors/Windows	Person Drs	A 716	0.15		0.4%
	Interior 3x7 wood doors in steel frames					
	Exterior 3x7 steel doors in steel frames					
8.30		OHD/Spec	A 6940	1.45		3.8%
	2 - 24' x 16' power operated steel overhead doors					
8.80		Glass/Glaz	A 50	0.01		0.0%
	1 - 5' x 4' window					
9.00	Finishes					
		Painting	A 484	0.10		0.3%
	Finish paint all drywall partitions					
	Finish paint all doors and frames					
10.0	Specialties	Toi Acces	A 120	0.03		0.1%
	Toilet room accessories - Paper dispensers, Mirrors, Grab bars, toilet partitions					
14.0	Conveying Systems		A 30000	6.25		16.6%
	10 ton bridge crane					
15.4	Mechanical	Plumbing	A 3000	0.63		1.7%
	1 Water closet					
	1 Lavatory					
15.6		HVAC	N.I.C.			

Ballpark Estimate Spread Sheet U.M.T.R.I. Continued

16.0	Electrical	A	9600	2.00	5.3%
	Incomming service 120/208 volt 3 phase				
	20 fc Lighting in the shop area				
	80 fc lighting in the office area				
	4 Duplex receptacles				
	Required exit lighting				
	Required emergency lighting				
TOTAL COST			181142	37.74	100.0%
	Builders Fee	15.0%	27171	5.66	
CONTRACT TOTALS			208313	43.40	

