

No. 146
July 1973

FLUTTER-LIKE OSCILLATIONS OF A PLANING PLATE

T. Francis Ogilvie

Young-Tsun Shen

Research sponsored by Office of Naval Research
N00014-67-A-0181-0019
NR 062-421

This document has been approved for public release
and sale; its distribution is unlimited.



Department of Naval Architecture
and Marine Engineering
College of Engineering
The University of Michigan
Ann Arbor, Michigan 48104

ABSTRACT

In the two-dimensional steady nonlinear problem of a planing plate, two distinct limiting flow regimes occur: In one, the usual planing problem, a jet (or spray) is thrown forward approximately parallel to the plate, whereas in the other there is a flow over the plate in the downstream direction and no fluid is thrown forward. The latter is equivalent to the case of a hydrofoil under the free surface with an infinitely long cavity at atmospheric pressure. If the plate has a large fixed angle of attack, there is a gradual transition from the hydrofoil flow to the true planing flow as speed is increased and/or load is decreased. However, if the angle of attack is small, the transition is relatively abrupt. Furthermore, for small angle of attack, either limiting type of flow can be analyzed on the basis of a linearized mathematical model, although the transition is intrinsically nonlinear.

In order to study the instability, the planing plate is assumed to oscillate sinusoidally in heave at a prescribed frequency, and the pertinent linearized problem is solved. Only the high-speed, lightly-loaded condition is considered, with the jet thrown forward. It is assumed that the effective location of the leading edge of the wetted portion oscillates fore and aft; the problem is equivalent to that of an airfoil with variable chord length. It is necessary to solve for the location of the leading edge by finding the time-dependent elevation of the water ahead of the plate. Then the lift on the planing plate is computed; it depends only on the reduced frequency parameter, and the damping is negative whenever this parameter has a value less than a critical value. This suggests that the flow is always unstable. However, it is found that the value of the frequency parameter for zero damping agrees fairly well with the value observed in experiments under actual conditions of spontaneous oscillation.

It is concluded that oscillation cannot occur until the speed is high enough that the flow has changed from a hydrofoil-like flow to a planing type of flow. After this transition has occurred, the flow is invariably unstable, and oscillation occurs at that frequency at which the damping coefficient just becomes negative. Unfortunately, the speed at which transition occurs cannot

yet be predicted, because the steady-motion problem is here treated in the classical manner, in which gravity is not considered; the steady solution is not unique. Also, no convincing arguments have yet been found to explain the observation that oscillation apparently occurs at the frequency at which the damping just becomes negative, rather than at some higher frequency at which damping would be more negative and the flow more unstable.

INTRODUCTION

Mottard (1965) reported some observations of a planing instability that appeared to be similar to flutter, but which involved just one mechanical degree of freedom (heave). He towed a large-aspect-ratio planing surface in such a way that it was free to heave but not to pitch. In a series of careful experiments, he found that there was a clearly defined critical speed at which heave oscillations occurred spontaneously. For a given geometry and a given load, the motion was stable for speeds less than the critical speed.

It has been known since the famous work of Wagner (1932) that the flow under a planing surface at small angle of attack is generally similar to that below an airfoil in an infinite fluid. The occurrence of wing flutter normally requires that two vibrational degrees of freedom be involved, for otherwise the hydrodynamic force provides positive damping, and a spontaneous oscillation cannot develop. One might expect the same requirement to apply to the occurrence of instability of a planing surface as in the airfoil case. However, Mottard checked carefully in his experiments to determine that no pitching motion occurred, or, at least, that pitching motion had no effect on the phenomenon that he was observing. His planing surface underwent a spontaneous oscillation *in heave alone*.

Mottard suggested that there was effectively a second degree of freedom because of the presence of the free surface. Ahead of the planing surface, the free surface oscillates at the same frequency as the planing surface itself but generally with a phase shift. Thus the location of the leading edge of the planing surface varies for two reasons: (1) the planing-surface immersion varies in time, and (2) the free-surface elevation just ahead of the planing surface varies. As we shall see, Mottard's hypothesis correctly explains the possibility of instability. We shall show too that the existence of a critical speed is related to Mottard's hypothesis, but the connection is not so straightforward as the flutter analogy might suggest.

Several years ago, Ogilvie (1969) tried to predict the conditions for instability by carrying out an analysis in which the planing surface was

treated as a heaving airfoil of variable chord. The instantaneous effective position of the leading edge was an unknown of the problem. He sought a formula for lift, presuming that there would be some definite speed at which that component of force in phase with heave velocity would become positive, indicating the onset of instability. But it did not work out that way. The lift depended just on the reduced frequency,

$$v = \omega l / 2U ,$$

where

- ω = radian frequency of oscillation,
- l = mean effective chord length,
- U = forward speed.

The reduced frequency does indeed have a critical value, according to this analysis: For $v > 0.213$, the damping is positive, and, for $v < 0.213$, the damping is negative. But, at any given speed, U , there is an entire range of frequencies, ω , at which an oscillation might occur with negative damping. The concept of a "flutter speed" is thereby lost.

Notwithstanding this discouraging result, we tried to estimate the value of v for the conditions in Mottard's experiments under which the instability occurred. Obtaining this estimate was not easy, because Mottard had not measured the effective chord length. However, using some fairly well-established semi-empirical relations given by Shuford (1958), Shen showed that, when instability occurred, v was rather close to the critical value, 0.213. This is demonstrated in Figure 1, where the points represent values derived from Mottard's report. The agreement is closest for the cases of largest aspect ratio. But in all cases the agreement is good enough that one is inclined to believe that the flutter concept is not all wrong.

Apparently, when instability does occur, the two-dimensional theory (without gravity) predicts approximately the correct frequency of the spontaneous oscillation. But the theory cannot be used to predict when instability actually will occur. There must exist an entirely different mechanism that inhibits instability at speeds below a critical value.

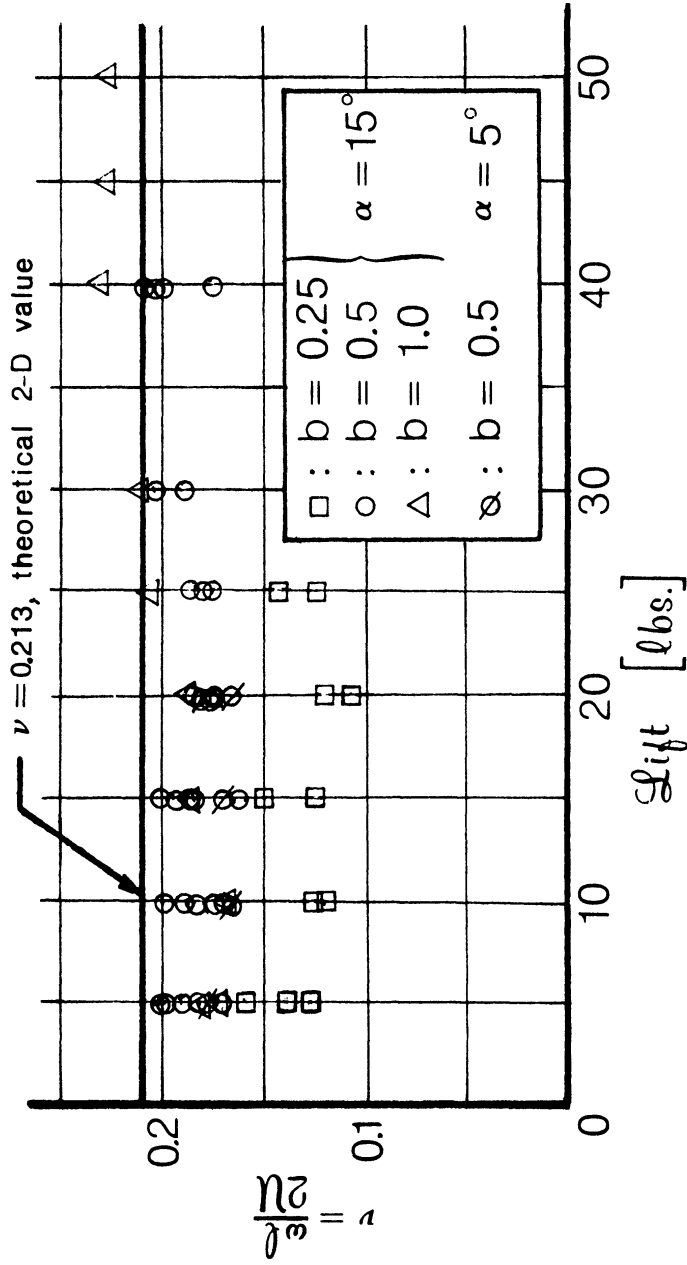

Figure 1. Reduced Frequency of Spontaneous Oscillation

(b = span; α = angle of attack)

When we discovered this situation, we thought that the stabilizing mechanism must be related either to the three-dimensionality of the flow or to the presence of gravity effects. We had observed that the predicted value of the critical reduced frequency was most in error for the low-aspect-ratio cases, which suggested the failure of the two-dimensional theory. On the other hand, we could reason that instability might be inhibited below a certain frequency, ω , rather than below a certain speed, U . Since the analysis by Ogilvie (1969) was deficient for low frequency oscillation, because of the neglect of gravity effects, it might be essential to include the latter in order properly to predict the onset of instability.

In either case, it was necessary to study more closely the steady-motion problem before trying to formulate and solve a more accurate oscillation problem. Rispin (1966) and Wu (1967) had recently shown how to treat the 2-D planing problem with gravity effects included. We could find no hint in their analyses of the elusive inhibiting mechanism that we sought, and the notorious difficulty of adapting the hodograph method (which they had used) to time-dependent problems did not encourage us to pursue that approach. So we decided to investigate the case of a planing surface with finite (if large) aspect ratio. The results were published by Shen & Ogilvie (1972).

In the process of carrying out these investigations, we found out quite accidentally that there was a third possible explanation, namely, that certain nonlinear effects prevent instability under some conditions. This appears to be a reversal of the usual role of nonlinearity in stability analyses: Frequently one predicts the onset of instability by means of a linearized mathematical model, knowing that the subsequent growth of the unstable motion will be drastically modified by nonlinear properties of the system. Here we are suggesting that nonlinear behavior in the *steady* flow sometimes makes the prediction of instability by a linear analysis invalid.

The basic argument is simple. If a planing plate starts up from rest carrying a given load (supported initially by some external means), it will be completely wetted on the under side at first; it must use all of the available area for developing the required hydrodynamic lift. The stagnation

point will lie very close to the forward edge of the plate. However, as speed increases, more and more lift is generated, and so the plate rises up in the water until the forward part is not fully wetted. With increasing speed, the effective lifting area reduces more and more. Eventually, the plate planes on a small strip just ahead of the trailing edge, and the actual length of the plate is of no consequence hydrodynamically; it could just as well extend infinitely far forward. The important length scale in the problem then depends on the effective chord, which we shall generally take as the distance between trailing edge and stagnation point. This is the configuration investigated by Ogilvie (1969). When a heave oscillation is superposed on such a steady motion, the position of the effective leading edge — and thus the effective chord — is free to oscillate too; this oscillation is characterized by a negative damping force. However, at the lower speeds, the stagnation point clings to the forward edge of the plate, and so the mobility of the effective leading edge — which gives the extra degree of freedom — does not exist. Thus, an oscillation under such conditions does not involve a negative damping force, and there is no instability.

In the next section, we consider the nonlinear steady-motion problem for a planing plate. This is the classical problem of Green (1936), which is also described by Milne-Thomson (1960). The most important consequence for our purposes is that, for a plate at small angle of attack, there is an abrupt transition from the low-speed, fully-wetted condition to the high-speed condition in which the plate acts as if it were semi-infinite in extent forward.

Then, in the following section, we outline the computation of lift for the unsteady motion case. This is the analysis that always predicts instability. It is presumably valid for speeds above the transition just mentioned.

In this paper, we still do not arrive at the point of actually predicting the critical speed at which instability occurs. There are at least two difficulties remaining. Firstly, the transition between the fully-wetted (or heavily loaded) planing condition and the partially-wetted (lightly loaded) condition can only be predicted on the basis of a nonlinear analysis which

incorporates Green's solution. However, that solution is non-unique, as is well known, unless gravity effects are included.* The obvious way to proceed is to use the analysis, including gravity effects, of Rispin (1966) and Wu (1967) for predicting the occurrence of the changeover. However, it is no small accomplishment to perform such calculations, and Rispin and Wu have not published any numerical results. Secondly, one must really solve the transition problem *with the oscillation superposed* to be sure that an oscillation with negative damping can indeed occur. For this part, it is probably valid to ignore the immediate effects of gravity, but the time-dependent nonlinear problem is formidable.

So we satisfy ourselves for the moment with showing (1) that a linear analysis does predict instability at all speeds and (2) that a mechanism exists that invalidates the stability analysis at low speeds and thus accounts for the observed delay of the onset of instability. We show these two things in reverse order.

*Alternatively, three-dimensionality or finiteness of depth may be used to make a *first approximation* unique.

THE NONLINEAR STEADY-MOTION PROBLEM

If gravity be neglected, the steady-motion problem is just the "gliding plate" problem of Green (1936). Since this problem and its solution are quite well-known [See Milne-Thomson (1960), for example], we only state here those aspects that are required so that the subsequent discussion makes sense.

The flow near the flat plate might look as shown in Figure 2. The physical plane, identified as the z plane, with $z = x + iy$, is mapped into three other planes, all shown in Figure 3. First is the plane of the complex velocity potential, $F(z) = \phi(x,y) + i\psi(x,y)$, where $\phi(x,y)$ is the real velocity potential. We set the value of the stream function, $\psi(x,y)$, equal to zero on the stagnation streamline, which is also the downstream free surface. On the upstream free surface, we set $\psi = Ua$, and so a is the [unknown] thickness of the jet (or spray sheet) far away. We also map the

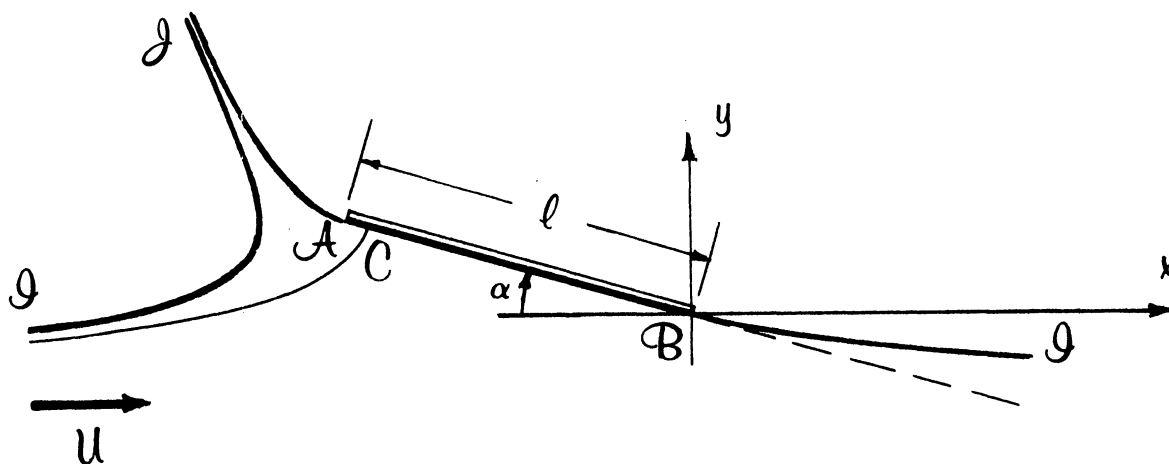
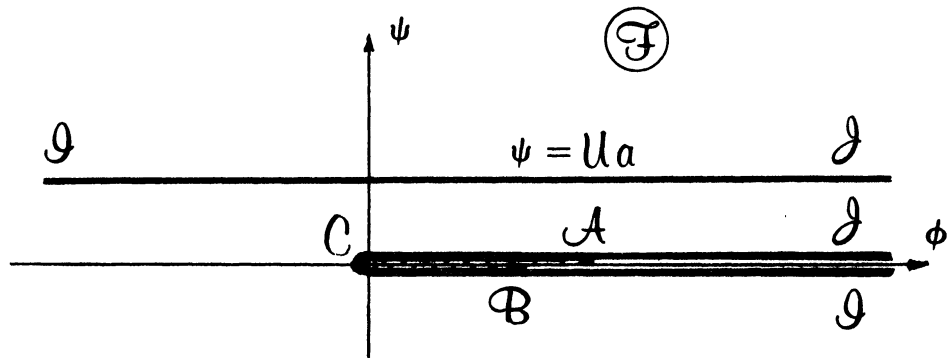
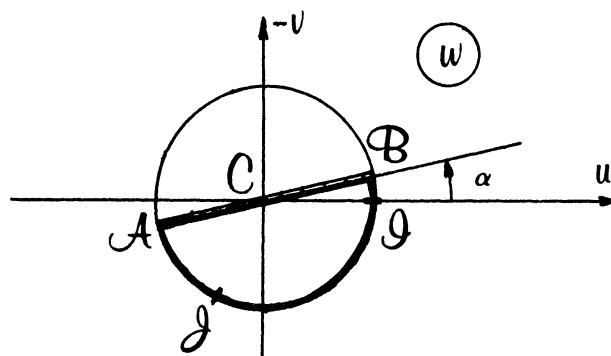

Figure 2. Nonlinear Planing Problem in the Physical Plane



(a) Complex-potential (F) plane



(b) Complex-velocity plane

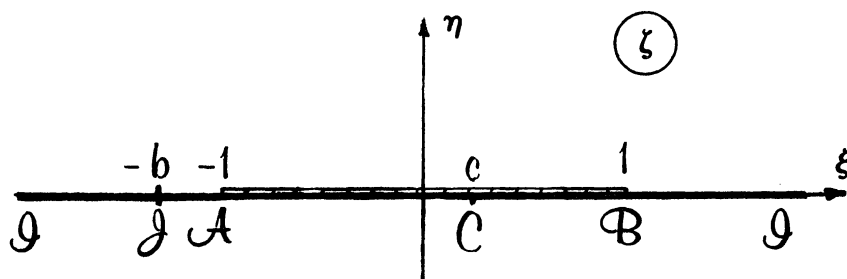

(c) Auxiliary (ζ) plane

Figure 3. Three conformal mappings of the fluid domain

fluid region onto a hodograph plane, denoted here by $w = dF/dz = u - iv$, where $u(x,y)$ and $v(x,y)$ are the fluid velocity components. On the plate, the direction of the flow is known, of course; the image of the plate is the straight line, ACB , in the w plane. On the free surface, the magnitude of the fluid velocity is known (since the pressure is constant there and we neglect gravity), and so the entire free surface maps into the semi-circle, $AJIB$. Finally, we perform a mapping onto the lower half of an auxiliary ζ plane, and the solution is usually obtained explicitly in terms of $\zeta = \xi + i\eta$. This last mapping has introduced two more constants, b and c .

The solution of this problem is as follows:

$$F(z(\zeta)) = \frac{Ua}{\pi} \left(\frac{\zeta - c}{b + c} - \log \frac{\zeta + b}{b + c} \right);$$

$$\begin{aligned} w(z(\zeta)) &= U e^{i\alpha} \frac{\zeta - c}{1 - \zeta c + i\sqrt{(1 - c^2)(\zeta^2 - 1)}} \\ &= U e^{i\alpha} \frac{1 - \zeta c - i\sqrt{(1 - c^2)(\zeta^2 - 1)}}{\zeta - c}. \end{aligned}$$

The two expressions for $w(z)$ are equivalent. The solution is complete when F and w have been expressed in terms of z , instead of ζ , and when a , b , and c are determined. One accomplishes the first by using the fact that $w(z) = dF(z)/dz$. Let

$$H(\zeta) = \frac{dF(z)}{d\zeta} = \frac{Ua}{\pi(b + c)} \frac{\zeta - c}{\zeta + b} = \frac{dF}{dz} \frac{dz}{d\zeta} = w \frac{dz}{d\zeta}.$$

Then one can obtain $z(\zeta)$ explicitly:

$$\begin{aligned}
 z &= \int_1^{\zeta} \frac{dt H(t)}{w(z(t))} \\
 &= \frac{ae^{-i\alpha}}{\pi(b+c)} \left\{ -c(\zeta - 1) + (1 + bc) \log \frac{\zeta + b}{b + 1} \right. \\
 &\quad + i\sqrt{(1 - c^2)(\zeta^2 - 1)} - ib\sqrt{1 - c^2} \log (\zeta + \sqrt{\zeta^2 - 1}) \\
 &\quad \left. - i\sqrt{(1 - c^2)(b^2 - 1)} \log \left(\frac{1 + b\zeta - \sqrt{(b^2 - 1)(\zeta^2 - 1)}}{\zeta + b} \right) \right\}.
 \end{aligned}$$

From the form of the solution for the region far from the plate, it is easily shown that $c = -\cos \alpha$, where α is the angle of attack. We obtain another condition just by expressing the length of the plate in terms of the above formula for $z(\zeta)$; this gives:

$$\ell = -\frac{a}{\pi(b+c)} \left(2c + (1 + bc) \log \frac{b-1}{b+1} - \pi\sqrt{1-c^2} (b - \sqrt{b^2-1}) \right).$$

If, say, b were specified, then this relationship could be treated as an equation to be solved for a , the jet thickness. There is no possibility now of *finding* b ; the solution is indeterminate unless we introduce further information, such as the lift or a more precise description of the behavior far away.

One can show that, as $|z| \rightarrow \infty$ in the fluid region,

$$w(z) = U \left[1 + \frac{ia \sin \alpha}{\pi(b+c)z} + \dots \right].$$

The first term obviously represents a uniform flow, and the second term represents an apparent vortex, of strength $-2a \sin \alpha / (b+c)$. Far, far away in the fluid region, one cannot distinguish between the planing plate (even with large angle of attack) and an airfoil.

As $\zeta \rightarrow -b$, the corresponding point in the z plane moves out in the jet, and so the direction of the corresponding fluid velocity gives the

orientation of the jet. This orientation depends on the value of b . If $b = 1$, we find that $v/u = -\tan \alpha$, which means that the jet is deflected forward, exactly parallel to the plate. At the other extreme, if $b = \infty$, then $v/u = 0$, and the jet travels exactly parallel to the x axis in the downstream direction; it goes over the planing plate instead of being thrown forward. (This is really the case of a supercavitating hydrofoil.)

Now consider how the solution behaves if the angle of attack, α , is very small. We substitute $c = -\cos \alpha = -1 + \frac{1}{2}\alpha^2 + \dots$ into the formula for $w(z(\zeta))$, obtaining:

$$w(z(\zeta)) = U e^{i\alpha} \left[1 - i\alpha \sqrt{\frac{\zeta - 1}{\zeta + 1}} + O(\alpha^2) \right]. \quad (1)$$

This has the familiar form for the velocity in the field of a flat-plate airfoil, and this relationship does not depend on the value of b (and thus on whether we have a planing surface or a supercavitating hydrofoil in mind). However, the right-hand side is given in terms of ζ , the variable in the auxiliary plane, and so we must substitute $\zeta(z)$ into this relationship. This can be done simply and explicitly only in two limiting cases.

For $b \gg 1$, one can show that

$$z(\zeta) \cong \frac{\ell}{4} (\zeta - 1)(\zeta + 3),$$

provided that $|\zeta| \ll b$. When this is inverted, we obtain two solutions:

$$\zeta(z) = -1 \pm 2\sqrt{\frac{z + \ell}{\ell}}.$$

Since we are interested in values of ζ in the lower half of the ζ plane, and since effectively z acts like ζ^2 , it is reasonable to require that

$$-2\pi \leq \arg(z + \ell) \leq 0.$$

The real axis from $x = -\ell$ to $x = +\infty$ is a branch cut, and so $\zeta(z)$ is unambiguous if we require that

$$\zeta(z) \cong -1 + 2\sqrt{\frac{z + \ell}{\ell}}.$$

In this case then, the complex velocity is given approximately by:

$$w(z) \cong U e^{i\alpha} \left(1 - i\alpha \sqrt{\frac{\sqrt{z + \ell} - \sqrt{\ell}}{\sqrt{z + \ell}}} \right) .$$

Near $z = -\ell$, this can be approximated by:

$$w(z) = U e^{i\alpha} \left[1 - \alpha \left(\frac{\ell}{z + \ell} \right)^{1/4} \right] ,$$

which shows explicitly that there appears to be a fourth-root singularity at the leading edge, in contrast to the usual square-root singularity at the leading edge of an airfoil.

If $b - 1 \rightarrow 0$, the above procedure does not work, because $z(\zeta)$ becomes singular at $\zeta = -1$. In fact, there is even some difficulty in using the apparently straightforward expression for plate length, ℓ :

$$\ell \cong \frac{a}{\pi(b + c)} \left\{ 2 + \left(b - 1 - \frac{b\alpha^2}{2} \right) \log \frac{b - 1}{b + 1} + \pi\alpha(b - \sqrt{b^2 - 1}) \right\} .$$

As $b - 1 \rightarrow 0$, the largest term here is that involving $\alpha^2 \log(b - 1)$, which gives us approximately:

$$\ell \cong -\frac{a}{\pi} \log(b - 1) .$$

Thus, as $b - 1 \rightarrow 0$, either $a \rightarrow 0$ or $\ell \rightarrow \infty$. The former is not very interesting, and the latter is inconvenient. What must actually happen, of course, is that a/ℓ should become very small.

It is really much more convenient at this point to define the "effective chord", ℓ_w , which is the distance between the trailing edge and the stagnation point. We obtain a formula for it by setting $\zeta = c$ in the exact formula for $z(\zeta)$, which then leads to the following approximation valid for $(b - 1) \ll 1$:

$$\ell_w \cong \frac{4a}{\pi\alpha^2(1 + \beta)} \left(1 + \frac{\pi\alpha}{2} \right) , \text{ where } b = 1 + \beta(\alpha^2/2) .$$

The interesting range of β will be $0 \leq \beta \ll 1$. (One can show, incidentally, that the jet moves off upward at a right angle to the plate if $b = -1/c$, in which case $\beta \cong 1$.) If we set $\beta = 0$, we have the simple relationship between jet thickness, a , and effective chord length:

$$\frac{a}{\ell_w} \cong \frac{\pi\alpha^2}{4} .$$

Nothing is said here about the actual chord length, ℓ , which clearly has become infinite (if we insist on a non-zero value of a).

We now return to finding an approximate formula for fluid velocity in this case. Equation (1) is awkward to use, since it indicates a square-root infinity at $\zeta = -1$; this point corresponds to the actual leading edge of the plate, which is so far away in the physical plane that we do not really care about it. However, (1) can be replaced by the following:

$$w(z(\zeta)) = U e^{i\alpha} \left(1 - i\alpha \sqrt{\frac{\zeta - 1}{\zeta - c}} + O(\alpha^2) \right) .$$

This is just as accurate* as (1), since $c \cong -1 + \alpha^2/2$. Next we can find $z(\zeta)$ in terms of ℓ_w , as is appropriate for this problem:

$$z(\zeta) = \frac{1}{2}\ell_w(\zeta - 1) .$$

Finally, we substitute this into the preceding formula for w , which gives:

$$w(z) \cong U e^{i\alpha} \left(1 - i\alpha \sqrt{\frac{z}{z + \frac{\ell_w}{2}}} \right) . \quad (2)$$

Here we have the expression that shows the equivalence of the planing problem to the problem of a flat-plate airfoil.

* We cannot use this relationship very close to $\zeta = c$, since the error there becomes very large, even if it is $O(\alpha^2)$. However, we no more expect our results to be accurate there than we expect ordinary thin-airfoil theory to give accurate answers in the vicinity of the airfoil leading edge.

The analogy between planing surface and airfoil was known a long time ago, of course. Wagner (1932) obtained the last equation above, for example. But Wagner really treated *only* the case that we here call the "lightly loaded" planing surface, that is, the case in which $l_w \ll l$. When the planing surface is lightly loaded, in this sense, the linear time-dependent analysis of our next section is presumably valid.

The critical point for us is to determine the conditions under which it really is valid to treat the planing surface as lightly loaded. One cannot expect to find a clear, unambiguous criterion, of course. But, for a planing plate at small angle of attack, we find that the demarcation may be sharper than one might expect. Figure 4 shows a 2-D lift coefficient for a planing plate, plotted against the ratio l_w/l . The lift coefficient is based on the effective chord, l_w . For an angle of attack of 5° , the lift coefficient is constant for the entire range, $l_w/l < 0.97$, which indicates that the value of l is mostly of no consequence; we could keep l constant and vary l_w , and the lift would vary just as it does for a flat-plate airfoil

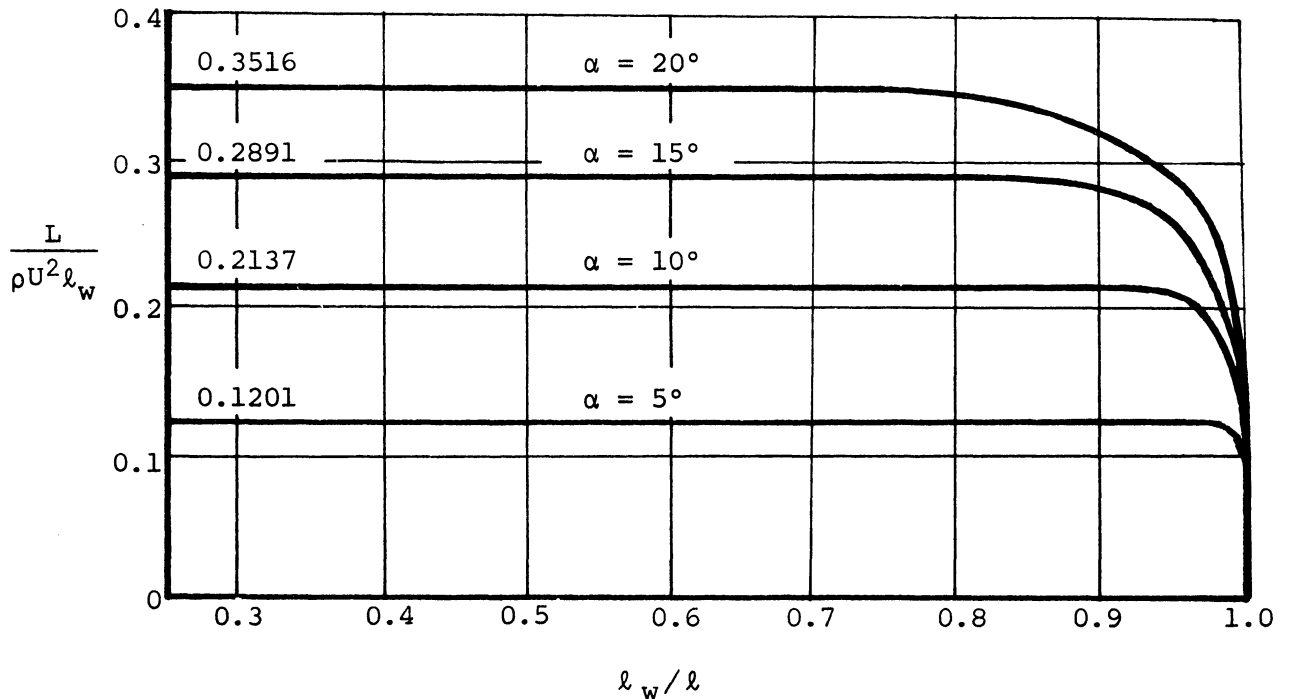

Figure 4. Lift coefficient as a function of *wetted length/chord length*

of chord l_w . Even at 10° , the same statements apply if $l_w/l < 0.90$. Thus it appears that there is a fairly clear boundary to the condition of "light loading." In particular, in the experiments of Mottard, a test would always start with $l_w/l = 1$, but rather abruptly the pseudo-airfoil condition would be attained, and this is the condition under which instability will occur, as we show in the next section.

Unfortunately, this analysis cannot indicate just when the change occurs. In fact, the indeterminateness of Green's solution does not allow us to find l_w at all. Shen and Ogilvie (1972) computed the wetted chord length at mid-span for certain planing-surface configurations, three-dimensionality providing the information for them that was lacking in Green's 2-D problem. At an angle of attack of 15° , for example, they found that a planing surface with aspect ratio 2.5 was lightly loaded at *mid-span* when the trailing edge (assumed to be straight) was at about the level of the undisturbed free surface. For smaller aspect ratios, it was necessary for the planing surface to rise even higher than that.* The value of l_w/l varies across the span, and so it is not certain just when the unstable oscillation can really begin.

Computations based on the analysis of Rispin (1966) and Wu (1967) would also give predictions of how the ratio l_w/l varies with the other important quantities, and such predictions would be much easier to evaluate than those of Shen and Ogilvie, simply because there is no spanwise variation to worry about. Of course, the 2-D results would have less relevance to Mottard's experiments than the high-aspect-ratio predictions of Shen and Ogilvie.

* Contrary to what one might guess intuitively, a high-aspect-ratio or 2-D planing surface can actually provide a considerable amount of lift even when its trailing edge is above the level of the undisturbed free surface. Of course, the flow pattern must be established first with the planing surface at a lower level. This phenomenon is not observable with a conventional low-aspect-ratio planing surface.

UNSTEADY MOTION

We now formulate and solve a time-dependent planing problem under the following assumptions:

- 1) The flat planing plate oscillates sinusoidally in heave only.
- 2) The angle of attack and the amplitude of oscillation are small enough that the problem can be completely linearized.
- 3) The loading is light enough that the fluid velocity in the corresponding steady-motion problem is given by Equation (2).
- 4) Gravity can be neglected except in that it makes the steady-motion solution unique.

The free surface at infinity is deflected downward an infinite amount according to the nonlinear gravity-free planing theory, and so the neglect of gravity might appear to make impossible the formulation of a linear free-surface problem. However, in a more precise statement of the problem in which gravity is included, there is a second length of importance, $2\pi U^2/g$, which is the length of gravity waves that travel at speed U . When we neglect gravity, we really mean that ϵ is very small, where ϵ is the ratio of chord length to this characteristic wavelength. In fact, the deflection of the free surface far from the planing surface is $O(\epsilon \log \epsilon)$ when measured on the wavelength scale, and it is logarithmically large only when measured on the scale of the chord length. Furthermore, even on the latter scale it becomes larger in just about the most gradual possible way, and so the traditional procedure for linearizing the free-surface problem appears to be reasonably safe.

For convenience we now change the coordinate system slightly to conform to aerodynamics practice in unsteady-motion problems. Let the chord extend from $x = 0$ to $x = 1$ when there is no oscillation; see Figure 5. The leading edge is defined as in the previous section: it is the location of the stagnation point. (We assume that the nonlinear steady-motion problem has been solved and that $l_w = 1$.) The trailing edge is a clearly defined sharp edge, which we assume to be located at $(1, d)$ during steady motion. Since the planing surface has an angle of attack, α , the coordinates of the leading edge are $(0, \alpha + d)$. The free surface is described by $Y = Y_0(x)$ in the

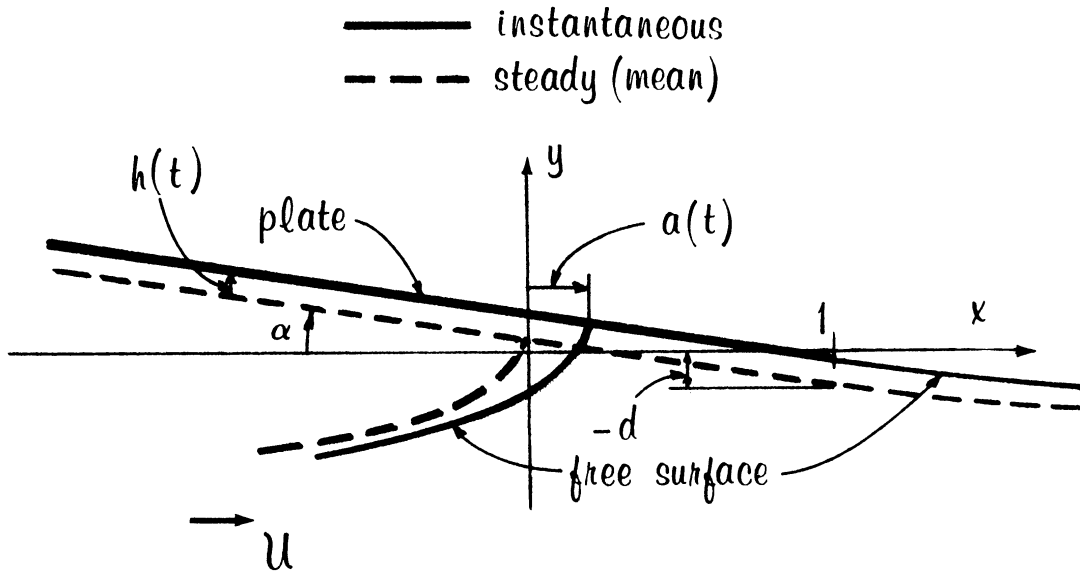

Figure 5. Coordinates for the unsteady-motion problem

absence of oscillation.

Let $h(t)$ be the heave displacement. In general, the equation of the planing surface is then:

$$y = (1 - x)\alpha + d + h(t) , \quad -\infty < x \leq 1 .$$

As noted, we assume that the plate extends indefinitely far forward, but we are interested only in that part between stagnation point and trailing edge. Let $x = a(t)$ denote the position of the effective leading edge. Then we consider that the fluid region is bounded by the planing surface for $a(t) \leq x \leq 1$ and by the free surface for $x \leq a(t)$ and for $1 \leq x$. If we define the free surface by the statement, $y = Y(x,t)$, it is evident that

$$Y(a(t),t) = (1 - a(t)) \alpha + d + h(t) ; \quad (3)$$

this condition ultimately determines the unknown variable, $a(t)$. In the steady motion problem, we note that the corresponding condition is:

$$\gamma_0(0) = \alpha + d. \quad (4)$$

Let the complete velocity potential be expressed:

$$Ux + \phi(x, y, t) = \text{Re}\{Uz + f(z, t)\},$$

where $z = x + iy$. The boundary conditions for the linearized ϕ problem are as follows:

$$\phi_y = -\alpha U + \dot{h}(t) \quad \text{on } y = 0, \quad a(t) \leq x \leq 1; \quad (5)$$

$$U\phi_x + \phi_t = 0 \quad \text{on } y = 0, \quad x < a(t) \quad \text{and} \quad x > 1; \quad (6)$$

$$U\gamma_x + \gamma_t = \phi_y \quad \text{on } y = 0, \quad x < a(t) \quad \text{and} \quad x > 1. \quad (7)$$

Equation (5) is the usual kinematic boundary condition on the planing surface. Equations (6) and (7) are, respectively, the dynamic and kinematic conditions on the free surface.

We shall presently require that $a(t)$ be small, in a certain sense. However, it would be disastrous to assume that $a(t)$ could be considered small enough so that the break in the fluid boundary might be placed approximately at $x = 0$ instead of at $x = a$ in the linearized problem. In the steady-motion problem, we certainly expect to find a square-root infinity in the velocity at the leading edge, as indicated in Equation (2). There is no reason to assume that such a singularity will be reduced in severity in the unsteady-motion problem, and so there will be just such a singularity present, *but it will be moving fore and aft*. If we try to represent the flow associated with such a moving singularity in terms of fixed singularities at the mean position, we encounter higher-order singularities, presumably 3/2-root infinities. Such nonintegrable singularities are completely unacceptable, and so we must avoid them by placing the leading edge at its instantaneous

position — at least, until we have partially solved the problem.

Equation (6) is a degenerate wave equation which admits of solutions representing arbitrary, nondispersive waves traveling in the positive x direction; its general solution is any function of the single variable $(x - Ut)$. We may suppose that, if we go far enough upstream, there is no disturbance at all, and so $\phi = 0$ on the free surface at infinity upstream. The only function of $(x - Ut)$ which has this property is the trivial one, that is, $\phi(x, 0, t) = 0$ on $y = 0$ for all $x < a(t)$. This implies further that:

$$\phi(x, -y, t) = -\phi(x, y, t) , \quad (8)$$

which permits the analytic continuation of $\phi(x, y, t)$ into the entire plane. However, $\phi = 0$ on $y = 0$ only on the upstream side of the leading edge, in general, and so we must make a branch cut along $y = 0$ from $x = a(t)$ to $x = \infty$, along both sides of which Equation (6) must be satisfied.

Except for the variability of $a(t)$, the above problem is now readily identified as a standard problem of aerodynamics: We seek a velocity potential satisfying a typical wing boundary condition, (5); there is no upstream disturbance; the condition (6), when applied downstream, is equivalent to requiring no pressure jump across a vortex sheet. The analytic continuation requires that ϕ_y be an even function of y , and so there is a condition identical to (5) applied on the upper side of the x axis, as well as on the lower side; thus the equivalent airfoil has zero thickness. We may expect to be able to obtain a solution in the manner of, say, Von Karman and Sears (1938), after which Conditions (3) and (7) should allow us to find $a(t)$.

Solution of the aerodynamics problem. It is convenient to write the solution in the complex form:

$$f(z, t) = \frac{1}{2\pi i} \int_{a(t)}^{\infty} \gamma(\xi, t) \log \left(\frac{\xi - z}{\xi} \right) d\xi , \quad (9)$$

where we take the argument of ξ and of $(\xi - z)$ both in the range between $-\pi$ and $+\pi$. For $a(t) \leq x \leq 1$, let

$$\gamma(x,t) = \gamma_0(x,t) + \gamma_1(x,t) ,$$

where

$$\gamma_0(x,t) = 2(-\alpha U + \dot{h}) \sqrt{\frac{1-x}{x-a(t)}} ,$$

$$\gamma_1(x,t) = \frac{1}{\pi} \sqrt{\frac{1-x}{x-a(t)}} \int_1^{\infty} \sqrt{\frac{\xi-a(t)}{\xi-1}} \frac{\gamma(\xi,t) d\xi}{\xi-x} .$$

For any function, $\gamma(x,t)$ in $1 < x < \infty$, the above solution satisfies the body condition, Equation (5). In the corresponding aerodynamics problem, $\gamma_1(x,t)$ is the vorticity induced on the airfoil by the downstream field of vorticity.

The downstream dynamic condition, Equation (6), is satisfied if we require only that

$$\gamma(x,t) = \gamma\left(1+, t - \frac{x-1}{U}\right) \quad \text{for } x > 1 . \quad (10)$$

Since our problem is formally identical to an aerodynamics problem, we can use the usual aerodynamic argument about conservation of vorticity to derive a condition on γ just behind the trailing edge:

$$U\gamma(1+,t) = -\frac{d}{dt} \int_{a(t)}^1 \gamma(\xi,t) d\xi .$$

The previous expressions for $\gamma(x,t)$ in $a(t) \leq x \leq 1$ can be used in the last equation, and this gives:

$$U\gamma(1+,t) = -\pi[1-a(t)]\ddot{h}(t) + \pi\dot{a}(t)[- \alpha U + \dot{h}(t)]$$

$$- \int_1^{\infty} d\xi \left\{ \gamma_t(\xi,t) \left[\sqrt{\frac{\xi-a(t)}{\xi-1}} - 1 \right] - \frac{1}{2}\gamma(\xi,t) \frac{\dot{a}(t)}{\sqrt{(\xi-1)(\xi-a(t))}} \right\} . \quad (11)$$

At this point, we know $\gamma(x,t)$ for $x > 1$ in terms of $\gamma(1+,t)$, and we know $\gamma(1+,t)$ as a functional of $\gamma(x,t)$ for $x > 1$. In addition, the quantity $a(t)$ remains unknown. A further simplification is needed.

The second linearization. The linearization of the problem required that α , $h(t)$, and $a(t)$ be small quantities. The results, as given in the last paragraphs, are decidedly nonlinear, however. Yet, since we are analyzing the stability of the steady motion of the planing surface, it is consistent with the usual approach to perturbation problems to assume that all disturbances are small enough that only linear combinations of small quantities occur.

The basic small parameter is α , the angle of attack. As the planing surface heaves an amount h , the location of the forward edge moves a distance which is of the order of magnitude of h/α , that is, $h = O(\alpha a)$. Therefore we require that $h = o(\alpha)$, which implies that $a = o(1)$.

The function $\gamma(x,t)$ is also small. Neglecting all quantities which are $o(h)$ or smaller, we have the following approximation of Equation (11):

$$U\gamma(1+,t) = -\pi\ddot{h}(t) - \pi\alpha U\dot{a}(t) - \int_1^\infty d\xi \gamma_t(\xi,t) \left(\sqrt{\frac{\xi}{\xi-1}} - 1 \right). \quad (12)$$

We could now substitute into the integrand from Equation (10), and we would then have a linear integral equation to be solved for $\gamma(1+,t)$. That equation can in fact be solved if a Fourier transform operator is applied to it. We do what is essentially equivalent: We assume that the motion is sinusoidal in time, so that we have to find only the complex amplitude of γ . Thus, let:

$$h(t) = h_0 e^{i\omega t};$$

$$a(t) = a_0 e^{i(\omega t - \epsilon)};$$

$$\gamma(x,t) = g e^{i\omega(t - x/U)}, \quad 1 < x < \infty.$$

The constants h_0 and a_0 are real, whereas g is generally complex. Now, in place of Equation (12), we have the following:

$$U g e^{-i\omega/U} = \pi\omega^2 h_0 - \pi i U \omega \alpha a_0 e^{-i\epsilon} - i\omega g \int_1^\infty d\xi e^{-i\omega\xi/U} \left(\sqrt{\frac{\xi}{\xi-1}} - 1 \right).$$

We solve this equation for g :

$$g = -4\pi U e^{i\nu} \left\{ \frac{i\nu h_0 + \frac{1}{2} \alpha a_0 e^{-i\varepsilon}}{K_0(i\nu) + K_1(i\nu)} \right\}, \quad (13)$$

where $\nu = \omega/2U$ and K_j is a modified Bessel function of the second kind. Since the arguments of the Bessel functions are purely imaginary, the functions could be rewritten in terms of Hankel functions of real argument, but we follow here the conventions of aerodynamics. Now $\gamma(x,t)$ is known everywhere downstream, except that it is expressed in terms of a_0 and ε , both of which remain to be determined.

Determination of $a(t)$. We must now compute the free surface shape, $Y(x,t)$, upstream of the planing surface (still in terms of the unknown $a(t)$) and then choose $a(t)$ so that Equation (3) is satisfied. In order to do this, we use Equation (7), which is an inhomogeneous wave equation. Its general solution is:

$$Y(x,t) = Y(x_0, t - (x - x_0)/U) + \frac{1}{U} \int_{x_0}^x \phi_Y(x', 0, \tau) dx', \quad (14)$$

where $\tau = t - (x - x')/U$, and x_0 is any number such that $x_0 \leq x$. From the form of the solution as given in (9), along with everything that we have derived since, we can express the integrand above:

$$\begin{aligned} \phi_Y(x, 0, \tau) &= -\frac{1}{2\pi} \int_{a(\tau)}^{\infty} \frac{d\xi \gamma(\xi, \tau)}{\xi - x} \\ &= (-\alpha U + \dot{h}(\tau)) \left(1 - \sqrt{\frac{1-x}{a(\tau)-x}} \right) \\ &\quad - \frac{1}{2\pi} g e^{i\omega t} \sqrt{\frac{1-x}{a(\tau)-x}} \int_1^{\infty} \sqrt{\frac{\xi}{\xi-1}} \frac{e^{-i\omega\xi/U} d\xi}{\xi-x}. \end{aligned}$$

This must now be substituted into the integral in Equation (14); we do not

bother writing out the result at this point however,

In the formula for $Y(x,t)$ above, we would like to let $x_0 \rightarrow -\infty$, since there is presumably no disturbance far upstream. However, the expression for $Y(x,t)$ includes the steady part of the deflection of the free surface, and we know that that is not a well-behaved quantity far upstream; it becomes logarithmically large with increasing distance. In order to be able to proceed, we subtract off the troublesome part. Thus, for steady motion, we have the following relationships:

$$\phi_Y(x,0,\tau) = -\alpha U \left(1 - \sqrt{\frac{1-x}{-x}} \right), \quad -\infty < x < 0;$$

$$\begin{aligned} Y(x,t) &= Y_0(x) = Y_0(x_0) + \frac{1}{U} \int_{x_0}^x \phi_Y(x',0,\tau) dx' \\ &= Y_0(x_0) - \alpha \int_{x_0}^x \left(1 - \sqrt{\frac{1-x'}{-x'}} \right) dx'. \end{aligned}$$

We can evaluate $Y_0(x_0)$ by substituting the last results into Equation (4), obtaining:

$$Y_0(x_0) = d + \alpha \left\{ 1 + \int_{x_0}^0 \left(1 - \sqrt{\frac{1-x'}{-x'}} \right) dx' \right\}.$$

In the unsteady-motion problem, we now assume that the displacement of the free surface far upstream is equal to the displacement in the steady-motion problem, i.e., that $Y(x_0,t) - Y_0(x_0) \rightarrow 0$ as $x \rightarrow -\infty$. We are explicitly assuming that the *unsteady* component of surface displacement vanishes upstream, even in the absence of gravity.* Now we substitute $Y_0(x_0)$ for $Y(x_0,t)$ in Equation

* We do not prove this statement. However, if it were not true, one would not expect the following steps to lead to finite results. In fact, the analysis does lead to undefined results if the frequency of oscillation approaches zero. This outcome *supports* the assumption, since it is necessary for the frequency to approach zero before the results become meaningless.

(14), at the same time letting $x_0 \rightarrow -\infty$. Finally, we substitute everything into Equation (3). This gives the equation to be solved for $a(t)$:

$$\begin{aligned} & \alpha [1 - a(t)] + d + h(t) \\ = & \alpha + d + \alpha \lim_{x_0 \rightarrow -\infty} \left\{ \int_{x_0}^0 \left(1 - \sqrt{\frac{1-x}{-x}} \right) dx - \int_{x_0}^{a(t)} \left(1 - \sqrt{\frac{1-x}{a(t)-x}} \right) dx \right\} \\ & + \frac{1}{U} \int_{-\infty}^0 dx \dot{h}\left(t + \frac{x}{U}\right) \left(1 - \sqrt{\frac{1-x}{-x}} \right) \\ & - \frac{ge^{i\omega t}}{2\pi U} \int_{-\infty}^0 dx e^{i\omega x/U} \sqrt{\frac{1-x}{-x}} \int_1^{\infty} \sqrt{\frac{\xi}{\xi-1}} \frac{e^{-i\omega\xi/U}}{\xi-x} . \end{aligned}$$

Note that g depends explicitly on a_0 and ϵ , as given in Equation (13).

A large amount of rather tedious algebra leads to the following simplification of this equation:

$$\begin{aligned} 0 = & \alpha a(t) \left(1 - \frac{1}{2} e^{i\nu} K_0(i\nu) + i \int_0^{\nu} d\zeta e^{i\zeta} K_0(i\zeta) \right) \\ & - i e^{i\nu} h(t) (K_1(i\nu) + K_0(i\nu)) \\ & - \frac{ge^{i\omega t}}{2\pi U} \int_1^{\infty} dx e^{-2i\nu x} \left[\frac{x+1}{x} E\left(\frac{x-1}{x+1}\right) - 1 \right] \\ & + \frac{\pi}{2} e^{-2i\nu} \left(\delta(\nu) + \frac{1}{\pi i\nu} \right) , \end{aligned}$$

where $E(x)$ is the complete elliptic integral of the second kind, and $\delta(\nu)$ is the Dirac delta function. In this form, it is obvious that the results are invalid for zero frequency. However, for finite frequency we can simply omit the delta function, and the result has unambiguous meaning.

The solution of this equation for $a(t)$ is simple in principle, although computation of the answer is clearly not simple. When $a(t)$ has thus been found, all other flow variables can be computed from formulas given previously.

THE DAMPING FORCE

The lift force can be computed by any of several methods. In any case, the result can be expressed as follows:

$$L(t) = \pi\rho U^2\alpha + \text{Re} \left\{ [A_1(v) + iA_2(v)] e^{i\omega t} \right\} ,$$

where

$$A_1(v) + iA_2(v) = -\pi\rho U^2 \left\{ i v h_0 \left(i v + \frac{2K_1(iv)}{K_0(iv) + K_1(iv)} \right) + \alpha a_0 e^{-i\varepsilon} \left(i v + \frac{K_1(iv)}{K_0(iv) + K_1(iv)} \right) \right\} .$$

(We have not previously bothered to denote just the real parts, but now it is essential to do this.)

In order to determine whether the damping is positive or negative, we must relate the phase of the time dependent part of $L(t)$ to the phase of $h(t)$. Recall that

$$h(t) = \text{Re} \left\{ h_0 e^{i\omega t} \right\} = h_0 \cos \omega t .$$

Then we have also that

$$\dot{h}(t) = -\omega h_0 \sin \omega t .$$

We substitute these back into the lift formula:

$$L = \pi\rho U^2\alpha + \frac{A_1(v)}{h_0} h(t) + \frac{A_2(v)}{\omega h_0} \dot{h}(t) .$$

If $A_2(v) < 0$, the damping is positive, and so the oscillation is stable.

We calculated the lift in the manner described above, and we found that the damping is negative if $\nu < 0.213$. We have now come back to the situation described in the Introduction: This analysis predicts instability at any speed, for, if U and l are given, the planing plate experiences negative damping at any $\omega < (2U/l) \cdot (0.213)$ (since $\nu = \omega l / 2U$). The existence of a minimum speed at which the instability occurs must be predicted on the basis of a nonlinear planing theory, in the manner of Green (1936), but with gravity included, as worked out by Rispin (1966) and Wu (1967).

REFERENCES

- Green, A. E., "Note on the Gliding of a Plate on the Surface of a Stream," *Proc. Cambridge Phil. Soc.*, **32** (1936) 248-252.
- Milne-Thomson, L. M., *Theoretical Hydrodynamics*, 5th Ed., Macmillan (1968).
- Mottard, E. J., "Investigation of Self-Excited Planing Vibration at Large Wetted Aspect Ratio," Report 2017, David Taylor Model Basin (1965).
- Ogilvie, T. F., "Instability of Planing Surfaces," Report No. 026, Dept. of Naval Arch. & Mar. Engin., U. Michigan (1969).
- Rispin, P. P., "A Singular Perturbation Method for Nonlinear Water Waves Past an Obstacle," Ph.D. thesis, Calif. Inst. Tech. (1966).
- Shen, Y. T., & Ogilvie, T. F., "Nonlinear Hydrodynamic Theory for Finite-Span Planing Surfaces," *J. Ship Research*, **14** (1972) 3-20.
- Shuford, C. L., Jr., "A Theoretical and Experimental Study of Planing Surfaces, Including Effects of Cross Section and Plan Form," Report 1355, Nat. Adv. Comm. Aero. (1958).
- Von Karman, T., & Sears, W. R., "Airfoil Theory for Nonuniform Motion," *J. Aero. Sci.*, **5** (1938) 379-390.
- Wagner, H., "Über Stoss- und Gleitvorgänge an der Oberfläche von Flüssigkeiten," *Z. ang. Math. Mech.*, **12** (1932) 193-215.
- Wu, T. Y., "A Singular Perturbation Theory for Nonlinear Free Surface Flow Problems," *International Shipbuilding Progress*, **14** (1967) 88-97.

KEY WORDS	LINK A		LINK B		LINK C	
	ROLE	WT	ROLE	WT	ROLE	WT
Planing						
Flutter						
Instability of Flow						
Lifting Surface Theory						

DOCUMENT CONTROL DATA - R & D

(Security classification of title, body of abstract and indexing annotation must be entered when the overall report is classified)

1. ORIGINATING ACTIVITY (Corporate author)		2a. REPORT SECURITY CLASSIFICATION	
Dept. of Naval Arch. & Marine Engineering College of Engineering, University of Michigan		UNCLASSIFIED	
		2b. GROUP	
3. REPORT TITLE			
FLUTTER-LIKE OSCILLATIONS OF A PLANING PLATE			
4. DESCRIPTIVE NOTES (Type of report and inclusive dates)			
Final Report			
5. AUTHOR(S) (First name, middle initial, last name)			
T. Francis Ogilvie Young-Tsun Shen			
6. REPORT DATE	7a. TOTAL NO. OF PAGES	7b. NO. OF REFS	
July 1973	28 + iii	10	
8a. CONTRACT OR GRANT NO.	9a. ORIGINATOR'S REPORT NUMBER(S)		
N00014-67-A-0181-0019	Report No. 146		
b. PROJECT NO.	9b. OTHER REPORT NO(S) (Any other numbers that may be assigned this report)		
NR 062-421	none		
c.			
d.			
10. DISTRIBUTION STATEMENT			
This document has been approved for public release and sale; its distribution is unlimited.			
11. SUPPLEMENTARY NOTES		12. SPONSORING MILITARY ACTIVITY	
		Office of Naval Research	
13. ABSTRACT			
<p>By means of a linear analysis, it is shown that the steady motion of a planing plate in two dimensions is always unstable in heave; the vertical motion of the water ahead of the plate causes the plate to have an effective chord length which oscillates along with any heave oscillation, and the damping coefficient of such an oscillation is negative if the reduced frequency is less than a computed critical value. This result suggests that 2-D planing is always unstable. However, in an experiment, in which the planing plate supports a given load and has a given angle of attack, the flow will be more like that of a supercavitating hydrofoil at low speeds, and only at high speed (the "lightly loaded condition") will the characteristic planing flow be established, with a jet (or spray) thrown forward by the plate. The instability exists when the latter condition has been reached</p>			