

5214

Admiral

363799

MM# 7166

UMTRI-91-41

A TEST PROCEDURE FOR EVALUATING THE OBSTACLE EVASION PERFORMANCE OF HEAVY TRUCKS

Final Report

P. Fancher

C. Winkler

S. Bogard

Z. Bareket

C. Mink

SEPTEMBER, 1991

UMTRI The University of Michigan
Transportation Research Institute



Technical Report Documentation Page

| | | | |
|---|---|--|-----------|
| 1. Report No. UMTRI-91-41 | 2. Government Accession No. | 3. Recipient's Catalog No. | |
| 4. Title and Subtitle A Test Procedure for Evaluating the Obstacle Evasion Performance of Heavy Trucks | | 5. Report Date September, 1991 | |
| | | 6. Performing Organization Code UMTRI-91-41 | |
| 7. Author(s) P. Fancher, C. Winkler, S. Bogard, Z. Bareket, C. Mink | | 8. Performing Organization Report No. | |
| 9. Performing Organization Name and Address The University of Michigan Transportation Research Institute 2901 Baxter Road, Ann Arbor, Michigan 48109 | | 10. Work Unit No. (TRAIS) | |
| | | 11. Contract or Grant No. | |
| 12. Sponsoring Agency Name and Address Motor Vehicle Manufacturers Association 7430 Second Avenue, Suite 300 Detroit, Michigan 48202 | | 13. Type of Report and Period Covered Final Report 07/90 - 09/91 | |
| | | 14. Sponsoring Agency Code | |
| 15. Supplementary Notes MVMA Technical Manager - Henry Seiff | | | |
| 16. Abstract This report contains the statement of a test procedure for evaluating the performance of multi-articulated heavy trucks in a sudden swerving maneuver. Rearward amplification between the motion of the lead unit (truck or tractor) and that of the last trailer is used to quantify performance in this maneuver. The statement of the procedure has sections on the purpose, scope, test course, vehicle condition and preparations, instrumentation requirements, data gathering and processing, proper execution of the test maneuver, analysis of the data, and interpretation of the results. Three appendices provide detailed information on the test course, the definition of the vehicle being tested, and outriggers for preventing rollover. | | | |
| 17. Key Words Rearward amplification, double and triple trailer combinations, C-trains, directional performance, dynamic offtracking | | 18. Distribution Statement | |
| 19. Security Classif. (of this report) | 20. Security Classif. (of this page) Unlimited | 21. No. of Pages 35 | 22. Price |

FOREWORD

This report delineates a test procedure for evaluating the obstacle avoidance performance of heavy trucks. The elements of the procedure described herein are based upon the following activities which were conducted for MVMA in a research investigation entitled "Performance Tests, Analyses, Signatures, and Measures: Obstacle Evasion":

- Review procedures that have been used and/or proposed for investigating rearward amplification. ("Rearward amplification" is the name for the performance measure used in the test procedure.)
- Devise graphs (performance signatures) for displaying performance characteristics.
- Define performance measures that capture the essence of the performance qualities contained in the performance signatures.
- Demonstrate the procedures and provide example results.
- Prepare a report delineating a test for evaluating obstacle avoidance performance. (This is the report.)

A similar procedure is being proposed to SAE as a new version (draft version) of J2179 entitled "A Test for Evaluating the Rearward Amplification of Multi-Articulated Heavy Vehicles."

In addition, a similar procedure has been recommended to NHTSA for use in evaluating the performance of vehicles weighing more than 80,000 lbs. Due to support from NHTSA, the procedure has been applied to several vehicle configurations. That work provided a substantial opportunity for developing practical methods for performing the tests and processing the data.

**A TEST PROCEDURE FOR EVALUATING THE
OBSTACLE EVASION PERFORMANCE OF HEAVY TRUCKS**

TABLE OF CONTENTS

| | | |
|----------|---|----|
| 1.0. | INTRODUCTION..... | 1 |
| 2.0 | STATEMENT OF THE TEST PROCEDURE | |
| 2.1. | Purpose..... | 4 |
| 2.2. | Scope..... | 4 |
| 2.3. | Test Course..... | 4 |
| 2.4. | Vehicle Condition and Preparation..... | 5 |
| 2.5. | Instrumentation Requirements..... | 6 |
| 2.6. | Data Gathering and Processing Capabilities Needed..... | 9 |
| 2.7. | Requirements for Proper Execution of the Test Maneuver..... | 10 |
| 2.8. | Analysis of the Test Data..... | 11 |
| 2.9. | Interpretation of the Results..... | 12 |
| Appendix | A..... | 13 |
| Appendix | B..... | 18 |
| Appendix | C..... | 37 |

A TEST PROCEDURE FOR EVALUATING THE OBSTACLE EVASION PERFORMANCE OF HEAVY TRUCKS

1.0. INTRODUCTION

During May and June of 1991, a new technique for measuring vehicle performance was evaluated in a pilot testing activity. This technique involves a test course especially laid out to excite the rearward amplification tendencies of multi-articulated heavy trucks. The form of the course is illustrated in Figure 1. The test driver follows this course in performing the test.

The vehicle is instrumented to measure lateral accelerations at the tractor's front axle and at the center of gravity of the sprung mass of the last trailer. The lateral acceleration of the tractor is the input that excites the vehicle motion. This input is quantified by computing its root-mean-square (rms) value over the lateral maneuvering section of the test course¹. The rms value is multiplied by the square root of 2 to provide an estimate of the amplitude of an equivalent sinusoid of lateral acceleration. The output is quantified by measuring the maximum absolute value of the lateral acceleration of the last trailer. The rearward amplification is the ratio of this measure of the output divided by the value of the input.

The pilot testing activity and subsequent studies of various methods of processing the data have led to a technique that can be used to measure rearward amplification to within approximately 10 percent of the average value with a confidence of 90 percent that the true value lies within this band. This level of confidence can be obtained using the results from five repeats of the test. These results are much better than any that have been obtained previously. Most of the previous work did not have any statistical treatment of the test data.

¹After investigating several possibilities for quantifying the input motion (including peak measured values of lateral accelerations, for example), it was found that the rms value of the lateral acceleration of the front axle of the tractor was a good indicator of the magnitude of the input and when this rms value was used, the variability of the test results was less than that obtained using other possibilities.

Rearward Amplification and Off-Tracking Course Layout

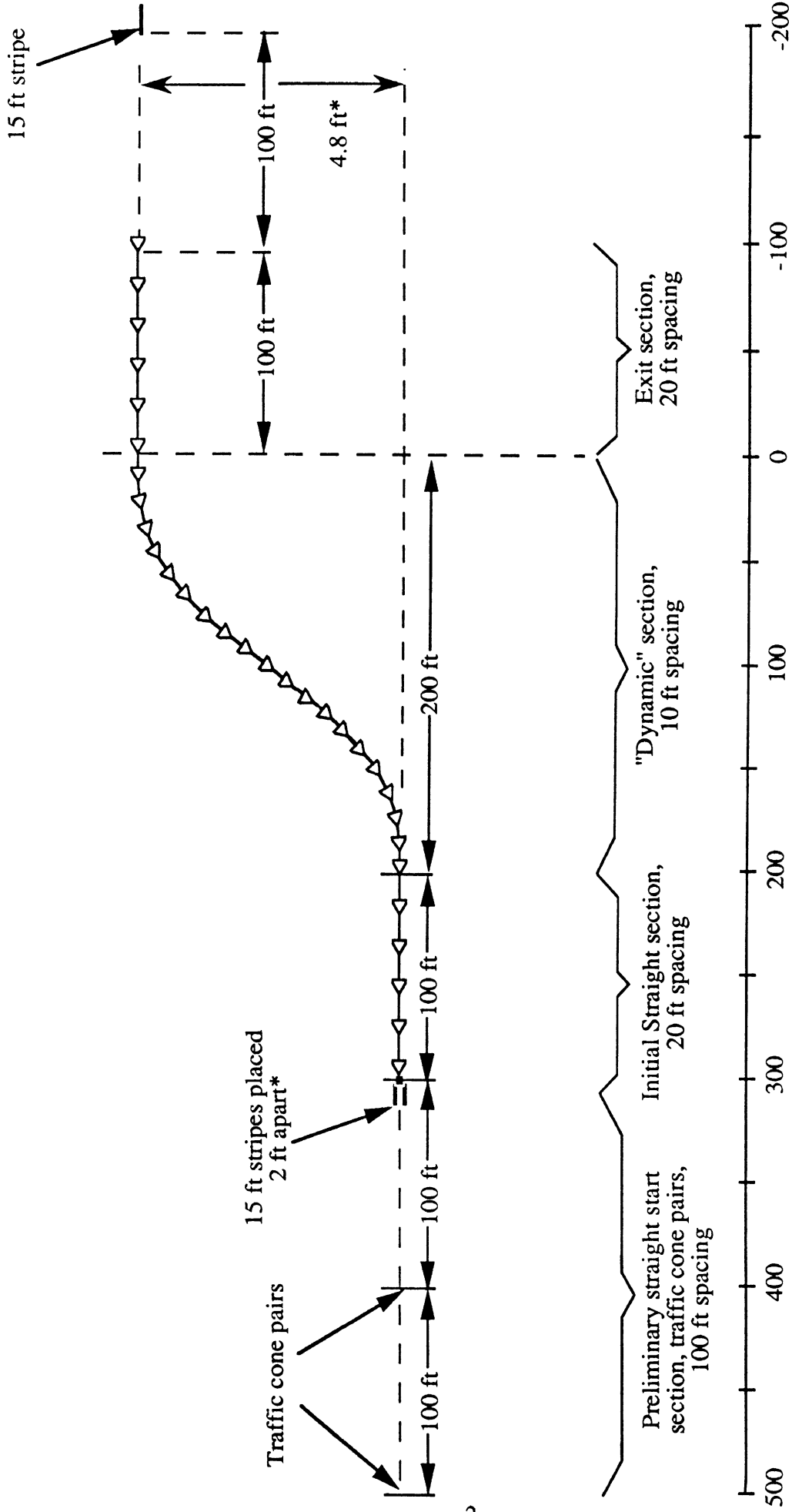

Figure 1.

* not drawn to scale

The formal statement of the new test procedure for evaluating obstacle evasion capability contains the following sections:

- (1) Purpose
- (2) Scope
- (3) Test Course
- (4) Vehicle Condition and Preparations
- (5) Instrumentation Requirements
- (6) Needed Data Gathering and Processing Capabilities
- (7) Requirements for Proper Execution of the Test Maneuver
- (8) Analysis of the Test Data
- (9) Interpretation of the Results

The procedure, which is presented in the next section of this report, is intended to meet the following general requirements:

- To be able to distinguish reliably between vehicles with different levels of performance in obstacle avoidance maneuvers
- To have reasonable instrumentation and data processing requirements
- To have repeatable results
- To be easy to perform correctly

2.0. STATEMENT OF THE TEST PROCEDURE

2.1. Purpose

This procedure is intended to be used for determining the rearward amplification and dynamic offtracking qualities of multi-trailer commercial vehicles (heavy trucks and buses).

2.2. Scope

The procedure applies to heavy vehicles weighing more than 26,000 pounds and particularly to those vehicles having two or more articulation joints that allow rotation in a horizontal plane. The procedure pertains to the lateral directional response of multi-articulated vehicles in specified swerving maneuvers that are performed at highway speeds without braking.

2.3. Test Course

The test involves the course illustrated in Figure 1. (Also see Appendix A.) The test driver is to follow this course in a manner that meets the requirements of Section 2.7. As shown in Figure 1, there is a straight section (300 feet long) leading up to a maneuvering section that attains a 4.8 foot lateral displacement in a longitudinal distance of 200 feet. After the maneuvering section, the course remains parallel to the original direction of travel for an additional 200 feet .

The lateral displacement of the course in the maneuvering section represents the motion of a point that is travelling at 55 mph for 2.5 seconds with a lateral acceleration of the form $A \sin(2\pi t/2.5)$ where t is time in seconds ($t = 0$ at the beginning of the maneuvering section) and $A = 0.15$ g.

The test course should be laid out on a proving grounds or other facility with adequate room to allow a heavy truck to reach 55 mph (or its maximum speed on level ground if that speed is less than 55 mph).

The facility needs to have space to allow the driver to recover control of the vehicle in case control is lost during the prescribed obstacle avoidance maneuver occurring on the maneuvering section.

The test course should be nearly level in all directions with a maximum slope that is less than one percent in any direction.

Ambient wind conditions should be less than 15 mph. Surface and wind conditions should be entered into the data sheets for each test.

The skid number of the dry test surface shall exceed 50 when measured at 55 mph. If available, the skid number of the surface should be recorded.

2.4. Vehicle Condition and Preparation

The condition of the vehicle's tires needs to be controlled. If the vehicle is to be permitted to operate with bias ply tires, it should be tested with new bias ply tires installed on the vehicle. Otherwise, the vehicle is to be tested with new radial ply tires. Tire wear should be less than 1/16 of an inch. The tire inflation pressures shall be set at the Tire and Rim Association specifications for the tire loads involved. Tire condition and inflation pressure shall be recorded on the data sheets. Also, the tires shall be identified on the data sheets. (See Appendix B for a proposed format for identifying the vehicle being tested.) Ideally, the cornering stiffnesses for the tires will have been measured and these values will be recorded to aid in identifying the vehicle. Identification of the tires is very important because the shear force capabilities of the tires (particularly cornering stiffness) have a large influence upon the results of these tests.

The vehicle should be uniformly loaded to the maximum weight that it is expected to carry (unless special test loads are specified). Ordinarily (unless otherwise specified), this will be at the gross combination weight rating, (GCWR) with axle loads close to their gross axle weight rating (GAWR). The height of the center of gravity of the test load should be set to the height specifically chosen for the test. (If practical, a tilt table test may be used to identify the rollover threshold of vehicles that are to be tested for rearward amplification.) The cg height and rollover threshold, if available, for the vehicle in the condition used in testing for rearward amplification shall be recorded on the data sheets. The axle loads and the payload's cg height shall also be recorded on the data sheets identifying the vehicle.

Since an unconstrained vehicle may roll over in this maneuver, the test vehicle shall be equipped with outriggers. (Information on outriggers is presented in Appendix C.)

2.5. Instrumentation Requirements

Transducers. Transducers shall be provided for measuring:

- Forward Velocity (V) with an accuracy of ± 0.5 mph over a range from 50 to 60 mph.
- Period of the maneuver (T) with an accuracy of ± 0.03 seconds over a range from 2.0 to 3.0 seconds.
- Lateral Acceleration of the center of the front axle (AYX) with an accuracy of $\pm 0.01g$ over a range from 0.0 to 0.2g. (This accelerometer may be attached to the axle and need not be mounted on a stabilized platform.)
- Lateral acceleration of the center of mass of the sprung mass of the last semitrailer (AYT) with an accuracy of $\pm 0.01g$ over a range from 0.0 to 0.5g. This accelerometer is to be mounted upon a stable platform to eliminate the influence of vehicle roll upon the measurement of lateral acceleration.

Measurements from the transducers listed above are sufficient to determine rearward amplification. The following instrumentation is needed to determine the quality of the driver's steering and to evaluate the level of transient high-speed (dynamic) offtracking.

The test course is marked by "plates" that have five sides and a point as illustrated in Figure 2. The point is placed on the test course. A water-jet is mounted at a selected point on the front axle to mark the vehicle's path. Alternatively, a laser system may be used to measure the distance from the vehicle's path to the desired path (the test course). The test driver shall be capable of following the desired path within ± 6 inches. Any test run that does not meet this requirement is unsatisfactory.

To determine transient high-speed offtracking, a water-jet device is attached to the rear axle of the last trailer at a point that corresponds to the selected point on the front axle. The distance from the path of this axle (as determined by the water mark) from a line tangent to the test course at the end of the maneuvering section (4.8 feet from the original direction of travel) is measured. If the last trailer overshoots the tangent line in the region from 50 feet before the end of the maneuvering section to 50 feet after the end of the maneuvering section, the maximum level of overshoot shall be recorded. If the last trailer's path does not overshoot in this region, the amount of "undershoot" at the end of the maneuvering section shall be recorded (See Figure 3).

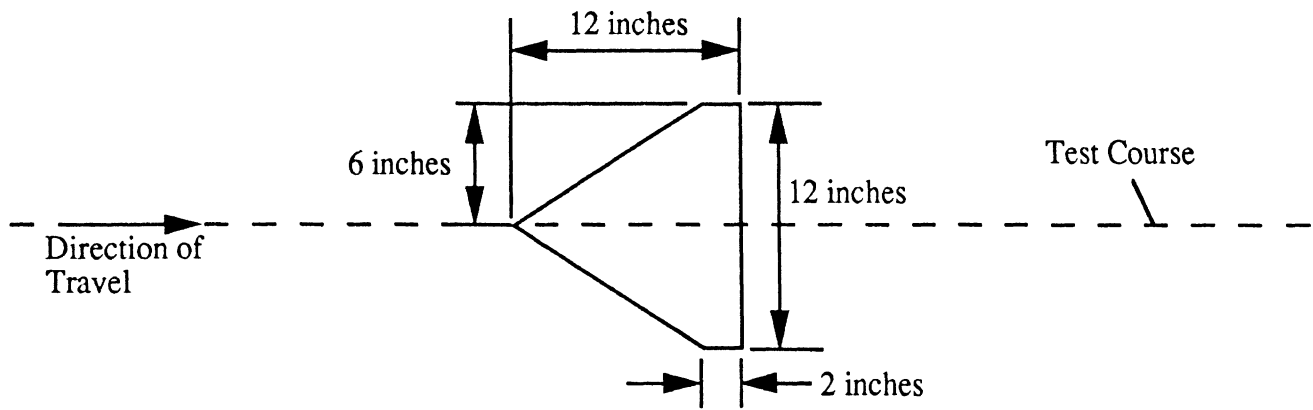

Figure 2. "Home" Plates used to mark the Test Course.

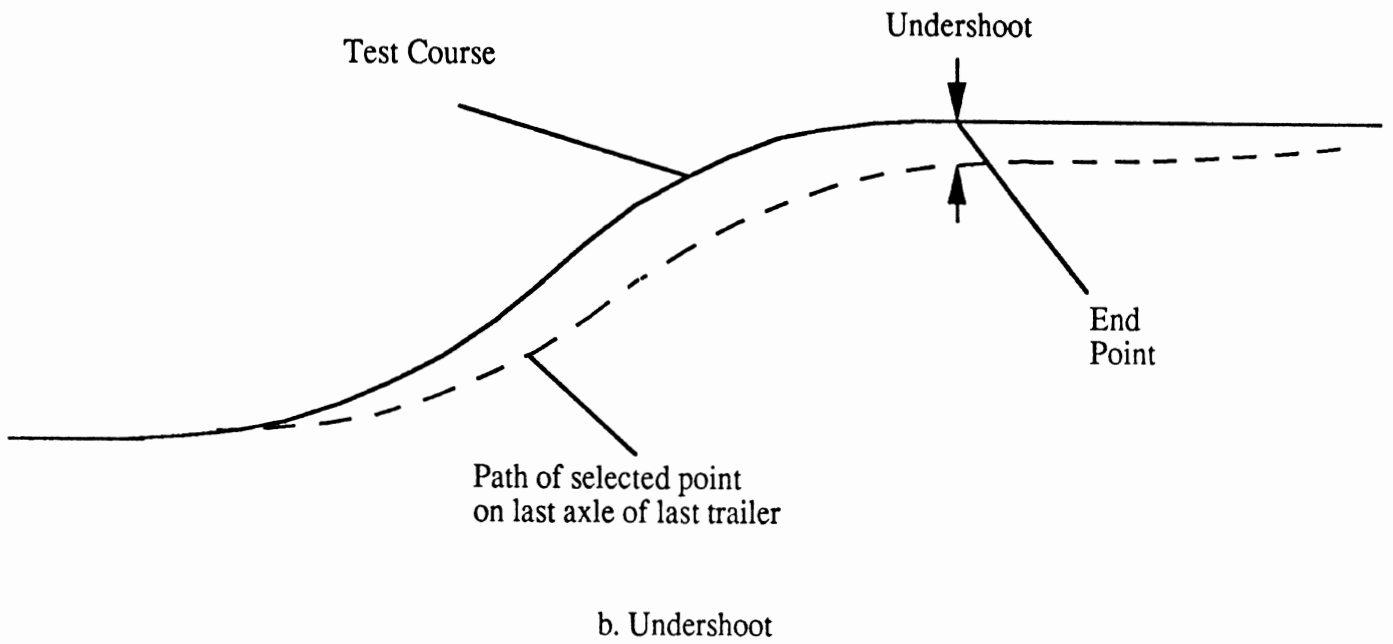
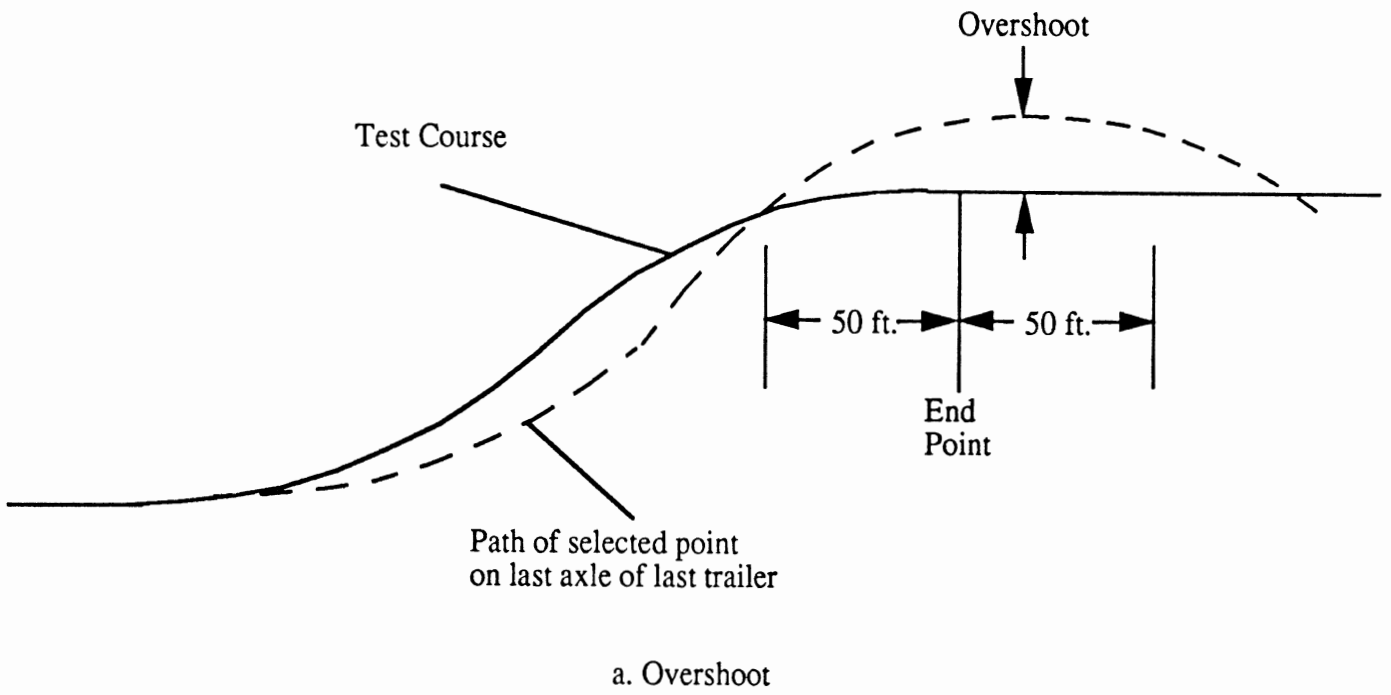

Figure 3. Transient high-speed offtracking; overshoot and undershoot.

2.6. Data Gathering and Processing Capabilities Needed

The data from the transducers described in Section 2.5 needs to be gathered as the test vehicle traverses the test course. The data should be recorded at a rate of 80 samples per second (or faster). At approximately 55 mph there will be approximately 10 seconds of data for each channel. The data channels that need to be recorded are as follows:

- Time (t)
- Time of the start of the maneuvering section and time of the end of the maneuvering section, with the difference being the period (T)

(If a laser system is available, record the path deviations at each plate.)

- Velocity (V)
- Lateral acceleration of the front axle (AYX)
- Lateral acceleration of the last trailer (AYT)

These signals need to have zero and full-scale calibration levels recorded, and they need proper anti-aliasing filters (low pass filters with cutoffs at 15 hz are suitable).

The data processing system shall be capable of smoothing these signals using a 0.2 second moving average. (A 0.2 second moving average means replacing each data point with the average of all data points within a band of ± 0.1 seconds about the original data point.)

The acceleration signals are to be smoothed twice using the simple moving average (or they can be smoothed in the frequency domain using fast Fourier transform techniques). (For an FFT procedure see Flannery, Press, Teukolsky, and Kettering: *Numerical Recipes the Art of Scientific Computing*, Chapter 12, Cambridge University Press, 1986.)

The root-mean-square (rms) value of AYX from the start to the end time of the maneuvering section will need to be computed. The maximum absolute value of AYT will need to be found.

The data processing system shall be capable of computing means, standard deviations, and confidence intervals for sets of runs.

2.7. Requirements for Proper Execution of the Test Maneuver

For a test run to be properly executed, the driver shall follow the test course so that a selected point on the front axle of the vehicle does not deviate more than ± 6 inches from the desired path defined by the test course. (The selected point may be located to aid the driver in following the course. A marker over the hood on the truck may aid the driver in sighting along the course.)

The vehicle's average velocity shall be within ± 1 mph of the selected speed over the maneuvering section. Nominally, the selected test speed will be 55 mph; however, lower speeds may be selected if the vehicle is not capable of traveling at 55 mph on the test course. (For example, if the vehicle is only capable of traveling at approximately 53 mph, a set of five runs at 53 ± 1 mph are needed to have a valid test sequence.) Higher speeds may also be run, but the course is intended for use at 55 mph.

The vehicle's velocity should be as constant as possible throughout the entire test course, but a ± 2 mph deviation from the selected speed is permissible on the initial and exit sections of the course if this helps the driver in executing the maneuver.

The period of time (T), taken from the start to the end of the maneuvering section shall be used to determine the average velocity over the maneuvering section. The average velocity is given by the following formula:

$$V = 200 / T \text{ (ft./sec.) or } 200 / 1.4667 T \text{ (mph).}$$

A set of five acceptable runs is required to establish vehicle performance. In addition to the velocity (that is, period) requirements prescribed above, the recorded values of AYX should not be excessively erratic. The effective value of AYX (that is, the rms value times 1.414) should not have a sample standard deviation greater than 0.02 g in a set of five runs. Ideally, the average value of AYX will be 0.15 g at 55 mph. At speeds other than 55 mph, the ideal level of AYX is given by the following formula:

$$AYX = 0.15 (2.5 / T)^2.$$

The effective value of AYX should be greater than 0.1 g for a run to be acceptable.

2.8. Analysis of the Test Data

The test data are analyzed as follows.

- (1) The checks for each test run as described in Section 2.7 are applied and bad runs are screened out.
- (2) For each test run that passes the checks, the average value of AYX is computed over the entire test course and this average is subtracted from AYX¹. The resulting signal is filtered twice using a moving average smoothing filter with a time width of 0.2 seconds. The rms value of this signal is computed from the time at the start of the maneuvering section to the time at the end of the maneuvering section. The effective value of AYX is 1.414 times the rms value. This effective value is saved to be used in the denominator of the calculation of rearward amplification.
- (3) The signal AYT is also filtered twice using a moving average with a width of 0.2 seconds. The peak value of this signal in the vicinity of the time of the end of the maneuvering section is read. This value is used as the numerator of the calculation of rearward amplification.
- (4) The value of rearward amplification is computed and stored for each run that has been found to be acceptable per the requirements of Section 2.7. (That is, the checks on V and AYX as specified in Section 2.7 are applied.) Once a set of five acceptable runs is obtained, the mean value (RAM) and the standard deviation (S) of the mean are computed. The result for the five acceptable runs is stated in the following form:

$$RA = RAM \pm 1.066 S$$

where $RAM = \Sigma RA_i / 5$ and $S^2 = \Sigma (RA_i - RAM)^2 / 5$ and RA_i represents the individual values of rearward amplification measured in each of the five acceptable test runs.

These values are to be used to determine whether the vehicle meets design targets or other target values of performance.

¹ The average value over the entire course rather than just the maneuvering section is used because the vehicle might enter and leave the maneuvering section with offsets in lateral acceleration.

2.9. Interpretation of the Results

The value of $RAM + 1.066 S$ represents an upper bound on the level of rearward amplification. From a statistical point of view and based upon the test results, there is a five percent chance that the rearward amplification is greater than $RAM + 1.066 S$. (To aid in interpreting results for various vehicles, the results for a typical Western double might be useful for comparison purposes. Results obtained by applying this test procedure to a heavily-laden (80,000 lb.) Western double with a rollover threshold of 0.35g and equipped with modern radial truck tires indicate that $RA = 2.0 \pm 0.1$ for a typical Western double.)

The transient high-speed offtracking boundary for a Western double is less than 24 inches of overshoot . At this time, a representative boundary value for undershoot (see Section 2.5) is tentatively set at 12 inches until further research is performed with "unresponsive" vehicles. The same set of five runs used to determine rearward amplification is to be used to determine the mean and sample standard deviations of overshoot or undershoot. The mean values of undershoot or overshoot shall be used to determine the performance level for dynamic (transient high-speed) offtracking.

This ends the specification of this test procedure.

APPENDIX A

The test course for measuring rearward amplification consists of a "lane-change-like" maneuver in which the vehicle is required to move laterally 4.8 feet as it moves forward 200 feet at 55 mph. The maneuver is conducted by driving the vehicle over a predefined course within prescribed limits of velocity and course deviation.

The test course begins with a 100 ft. straight section, followed by a 200 ft. "dynamic" section, and a 100 ft. straight exit section. The "dynamic" section is defined as a path which, if followed precisely at a forward velocity of 55 mph, will produce a lateral acceleration time history in the form of one cycle of a sine wave with an amplitude of ± 0.15 g. and a period of 2.5 seconds. Figure 1 diagrams the course. Table A.1 below details the specific distances for marking the initial straight, "dynamic," and exit sections of the course. The plate orientation is such that the course always passes through the tip of the plate and the center of the edge opposite the tip. Plate geometry is detailed in Figure 2.

| <u>X in Feet</u> | <u>Y in Inches</u> | <u>X in Feet</u> | <u>Y in Inches</u> |
|------------------|--------------------|------------------|--------------------|
| -100.0 | 0.0 | 110 | 33.4 |
| -80 | 0.0 | 120 | 39.5 |
| -60 | 0.0 | 130 | 44.4 |
| -40 | 0.0 | 140 | 48.6 |
| -20 | 0.0 | 150 | 52.1 |
| 0 | 0.0 | 160 | 54.6 |
| 10 | 0.1 | 170 | 56.3 |
| 20 | 0.5 | 180 | 57.2 |
| 30 | 1.3 | 190 | 57.6 |
| 40 | 2.8 | 200 | 57.6 |
| 50 | 5.0 | 220 | 57.6 |
| 60 | 8.0 | 240 | 57.6 |
| 70 | 11.8 | 260 | 57.6 |
| 80 | 16.6 | 280 | 57.6 |
| 90 | 22.0 | 300 | 57.6 |
| 100 | 27.8 | | |

Table A.1

To measure transient high-speed offtracking, the same course layout is used with an additional reference line placed tangent to the exit section of the course. The line is 100 ft.

long with its center located at the last plate in the "dynamic" section of the course. The lateral offset of the line is 102 inches. Figure A.3 shows the location and orientation of the line relative to the course.

Using lasers to indicate the start and end of the path requires specially shaped plates. The shape creates an identifiable pattern in the data collected by the lasers. Knowing the velocity of the vehicle, it is then possible to correlate the position of the vehicle to the collected data. Two sets of three plates are detailed in Figures A.4 and A.5.

Below is a list of the materials UMTRI used to mark the test course:

1. Thin Sheet Metal - used to cut out the plates that marked the path.
2. Putty - used to secure the plates to the road surface. This proved to be a very convenient way of temporarily securing the plates.
3. Heavy String - used as a reference marker for the off-tracking measurement.
4. Paint - used to permanently mark the plate, traffic cone, stripe, and string locations.
5. Bright Durable Material - used to mark the entry and exit of the path. These helped the driver align the train with the path.
6. Traffic Cones - used to mark the course entry and exit.

Off-Tracking Reference Line

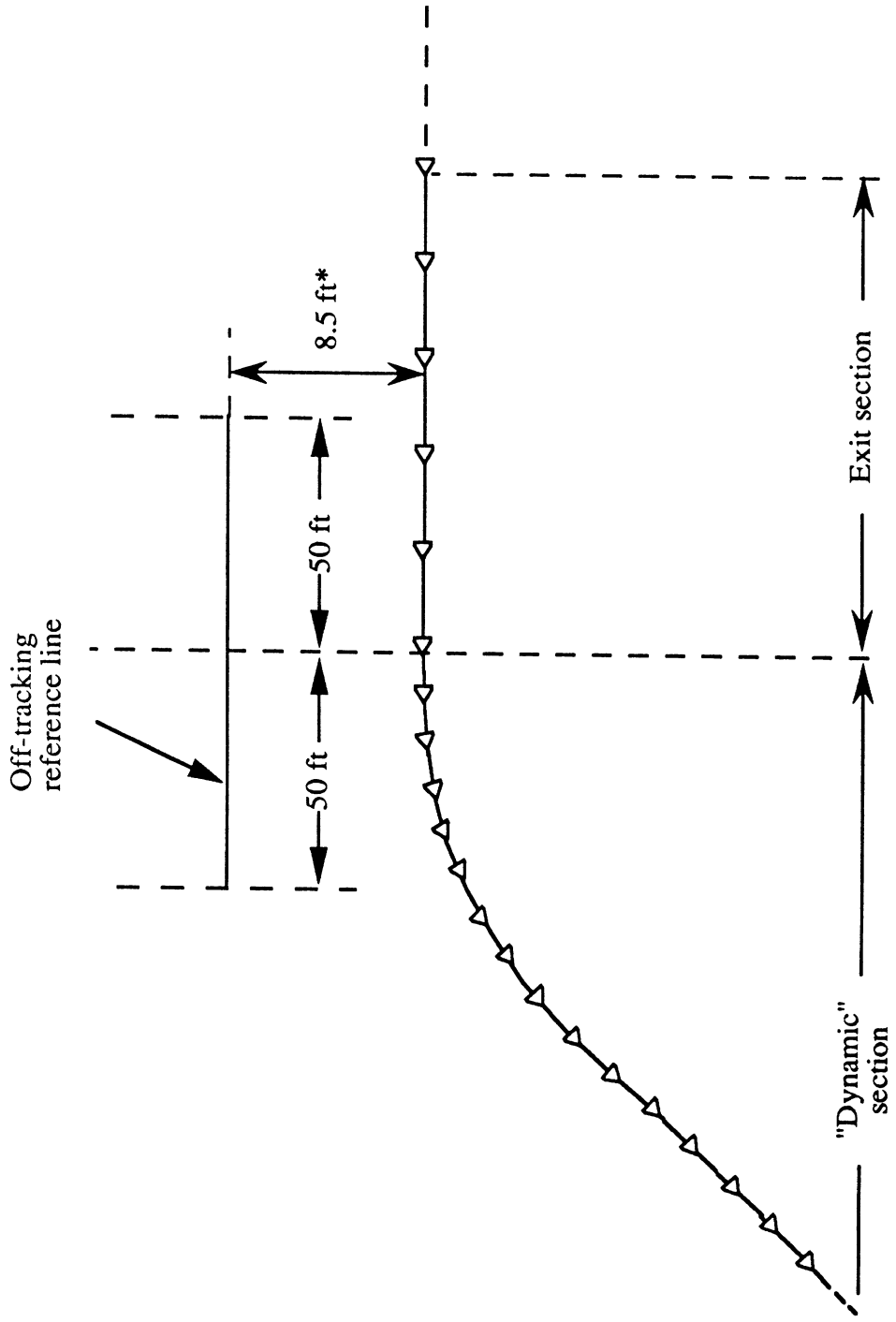

* not drawn to scale

Figure A.3. Lateral Offset Reference Line

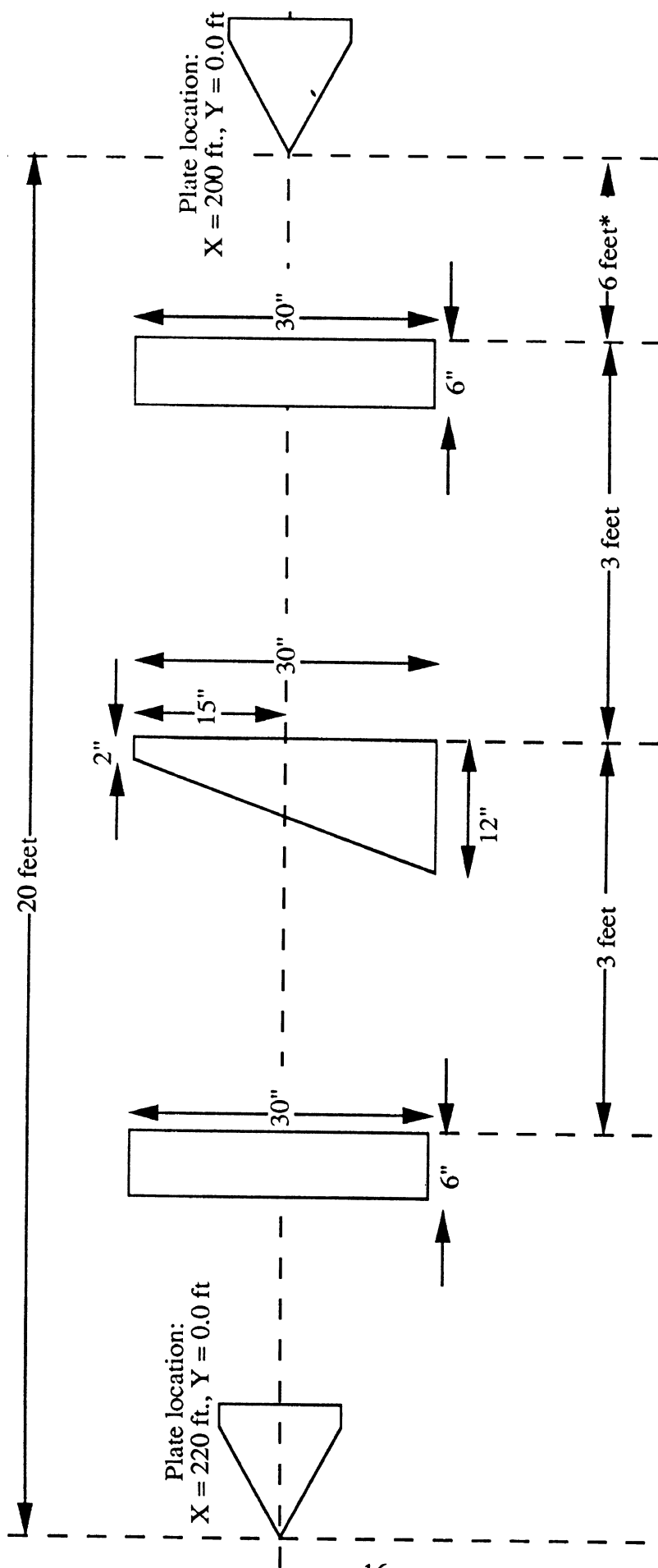

Figure A.4. Start of Curve Plates

* not drawn to scale

APPENDIX B

VEHICLE DEFINITION

(Unit and Articulated Heavy Trucks)

This appendix contains a very complete definition/description of a heavy truck. Information on the braking system, the engine, and the power transmission system may not be relevant to a swerving maneuver such as the one used in this obstacle evasion test procedure. However, tire characteristics, axle loadings, center of gravity heights, and roll related characteristics such as track widths and suspension types can have important influences on the results of this test.

The following material in this Appendix provides an example form to be used in defining a truck or truck combination and the condition of the vehicle at the time it was tested. For this obstacle evasion test, information on the engine, power transmission, and braking systems are probably not needed. The amount of information to be recorded is left to the discretion of the organization responsible for the experiments.

Vehicle Definition (Unit and Articulated Heavy Trucks)

Unit Trucks and Tractors

General

Chassis Cab

Year _____ Make _____ Model _____ Mileage _____
 VIN _____ Fleet No _____ GVWR _____ GCWR _____
 Status: Production Pilot Prototype
 Pre-prototype Development Pretest
 Component Experimental
 Cab Style: COE Cab Forward Conventional
 Short Nose Conventional
 Options: Air Conditioning Other _____

Body

Year _____ Make _____ Model _____ ID No. _____
 Description _____

Loading -----

Major Dimensions†

AF _____ mm BA _____ mm BBC _____ mm BH _____ mm
 BL _____ mm CE _____ mm CH _____ mm FH _____ mm
 FMH _____ mm OL _____ mm WB _____ mm

Mass

Tire Loads

| | | | | | |
|------------------------|---------------|---------------|---------------|---------------|---------------|
| Axle No. (from front): | _____ 1 _____ | _____ 2 _____ | _____ 3 _____ | _____ 4 _____ | _____ 5 _____ |
| Left Side: | _____ kg | _____ kg | _____ kg | _____ kg | _____ kg |
| Right Side: | _____ kg | _____ kg | _____ kg | _____ kg | _____ kg |

† Figure I.1 identifies these and other dimensions.

Drive Train

Engine

Make _____ Model _____ Displc _____ Config _____
Fuel: [] Gasoline [] Diesel [] Alcohol
Stroke: [] Two Stroke [] Four Stroke
Induction: [] Carburetor [] Fuel Injection [] Turbo-charged

Power Transmission

Transmission

Make _____ Model _____ Number of Forward Gears _____
[] Manual [] Automatic [] OD Range Selector

Full-Time Drive Axles

Make _____ Model _____ Axle(s) No(s) _____
[] Single Speed [] Two Speed Ratio(s) _____
[] Inter-axle Diff. Lock

Selectable Drive Axles

Make _____ Model _____ Axle(s) No(s) _____
[] Single Speed [] Two Speed Ratio(s) _____
[] Inter-axle Diff. Lock

Axles

| Axle No. (from front): | 1 | 2 | 3 | 4 | 5 |
|---|-------|-------|-------|-------|-------|
| Spacing from preceding axle (Sn) [†] , mm: | _____ | _____ | _____ | _____ | _____ |
| Make: | _____ | _____ | _____ | _____ | _____ |
| Model: | _____ | _____ | _____ | _____ | _____ |
| Load rating, kg: | _____ | _____ | _____ | _____ | _____ |
| Axle Width (AW) [†] , mm: | _____ | _____ | _____ | _____ | _____ |
| Track width (TW) [†] mm: | _____ | _____ | _____ | _____ | _____ |
| Dual spacing (DS) [†] , mm: | _____ | _____ | _____ | _____ | _____ |
| Steering: | [] | [] | [] | [] | [] |
| Self-Steering: | [] | [] | [] | [] | [] |
| Drive: | [] | [] | [] | [] | [] |
| Lift: | [] | [] | [] | [] | [] |

Suspension No. _____

Includes Axle(s) No(s): _____

Make: _____ Model: _____ Load Rating, kg: _____

Style — Single axle suspensions

Leaf Spring Air Lift
 Other _____

Style — Multi-Axle Suspensions

Walking Beam Four Leaf Air Torsion Bar
 Other _____

Spring(s)

Make _____ Model _____

Multi-Leaf Taper Leaf No. of Leaves _____ Length, mm _____
 Air Torsion Bar Rubber Block
 Other _____

Remarks _____

Suspension No. _____

Includes Axle(s) No(s): _____

Make: _____ Model: _____ Load Rating: _____

Style — Single axle suspensions

Leaf Spring Air Lift
 Other _____

Style — Multi-Axle Suspensions

Walking Beam Four Leaf Air Torsion Bar
 Other _____

Spring(s)

Make _____ Model _____

Multi-Leaf Taper Leaf No. of Leaves _____ Length, mm _____
 Air Torsion Bar Rubber Block
 Other _____

Remarks _____

Suspension No. _____

Includes Axle(s) No(s): _____

Make: _____ Model: _____ Load Rating, kg: _____

Style — Single axle suspensions

Leaf Spring Air Lift
 Other _____

Style — Multi-Axle Suspensions

Walking Beam Four Leaf Air Torsion Bar
 Other _____

Spring(s)

Make _____ Model _____

Multi-Leaf Taper Leaf No. of Leaves _____ Length, mm _____
 Air Torsion Bar Rubber Block
 Other _____

Remarks _____

Suspension No. _____

Includes Axle(s) No(s): _____

Make: _____ Model: _____ Load Rating: _____

Style — Single axle suspensions

Leaf Spring Air Lift
 Other _____

Style — Multi-Axle Suspensions

Walking Beam Four Leaf Air Torsion Bar
 Other _____

Spring(s)

Make _____ Model _____

Multi-Leaf Taper Leaf No. of Leaves _____ Length, mm _____
 Air Torsion Bar Rubber Block
 Other _____

Remarks _____

Steering System

Gear Make: _____ Gear Model: _____
 Assist: Manual Integral Asst. Linkage Asst.
 Gear Location: Frame Axle
 Ahead of W C Behind W C

 Ratios: Overall: _____ :1 Gear: _____ :1

 Pitman Arm Length, mm _____ Steering Arm Length, mm _____

 Ackerman wheelbase, mm _____

 Handwheel Diam.: Vertical _____ Horizontal _____

 Remarks _____

Brakes

Actuation

Air
 Hydraulic: Vacuum Asst. Hydraulic Power

Wheel Brakes

| Axle No. (from front): | 1 | 2 | 3 | 4 | 5 |
|------------------------|--------------------------|--------------------------|--------------------------|--------------------------|--------------------------|
| Make: | _____ | _____ | _____ | _____ | _____ |
| Disc: | <input type="checkbox"/> | <input type="checkbox"/> | <input type="checkbox"/> | <input type="checkbox"/> | <input type="checkbox"/> |
| Drum: | <input type="checkbox"/> | <input type="checkbox"/> | <input type="checkbox"/> | <input type="checkbox"/> | <input type="checkbox"/> |
| Disc or Drum size: | _____ | _____ | _____ | _____ | _____ |
| Wedge: | <input type="checkbox"/> | <input type="checkbox"/> | <input type="checkbox"/> | <input type="checkbox"/> | <input type="checkbox"/> |
| Wedge Angle, deg: | _____ | _____ | _____ | _____ | _____ |
| S-Cam: | <input type="checkbox"/> | <input type="checkbox"/> | <input type="checkbox"/> | <input type="checkbox"/> | <input type="checkbox"/> |
| Slack Length, mm: | _____ | _____ | _____ | _____ | _____ |
| Automatic Slacks: | <input type="checkbox"/> | <input type="checkbox"/> | <input type="checkbox"/> | <input type="checkbox"/> | <input type="checkbox"/> |
| Air Chamber Type: | _____ | _____ | _____ | _____ | _____ |
| Spring Brake: | <input type="checkbox"/> | <input type="checkbox"/> | <input type="checkbox"/> | <input type="checkbox"/> | <input type="checkbox"/> |
| Anti-lock: | <input type="checkbox"/> | <input type="checkbox"/> | <input type="checkbox"/> | <input type="checkbox"/> | <input type="checkbox"/> |

Anti-Lock Make: _____ Anti-Lock Model: _____

Remarks _____

Tires and Wheels

Axle No. (from front): 1 2 3 4 5

Wheels

| | | | | | |
|--------------|-----------------------------|-----------------------------|-----------------------------|-----------------------------|-----------------------------|
| Make: | <u> </u> | <u> </u> | <u> </u> | <u> </u> | <u> </u> |
| Spoke Style: | [] | [] | [] | [] | [] |
| Disk Style: | [] | [] | [] | [] | [] |
| Rim Size: | <u> </u> | <u> </u> | <u> </u> | <u> </u> | <u> </u> |

Tires

| | | | | | |
|-----------------------|-----------------------------|-----------------------------|-----------------------------|-----------------------------|-----------------------------|
| Make: | <u> </u> | <u> </u> | <u> </u> | <u> </u> | <u> </u> |
| Model: | <u> </u> | <u> </u> | <u> </u> | <u> </u> | <u> </u> |
| Size and Load Range: | <u> </u> | <u> </u> | <u> </u> | <u> </u> | <u> </u> |
| Tread Style: | <u> </u> | <u> </u> | <u> </u> | <u> </u> | <u> </u> |
| Tread Condition; New: | [] | [] | [] | [] | [] |
| Half Worn: | [] | [] | [] | [] | [] |
| or Full Worn: | [] | [] | [] | [] | [] |
| Tread Depth, mm: | <u> </u> | <u> </u> | <u> </u> | <u> </u> | <u> </u> |
| Pressure, kpa: | <u> </u> | <u> </u> | <u> </u> | <u> </u> | <u> </u> |

 Taken: [] Hot or [] Cold

VEHICLE DEFINITION

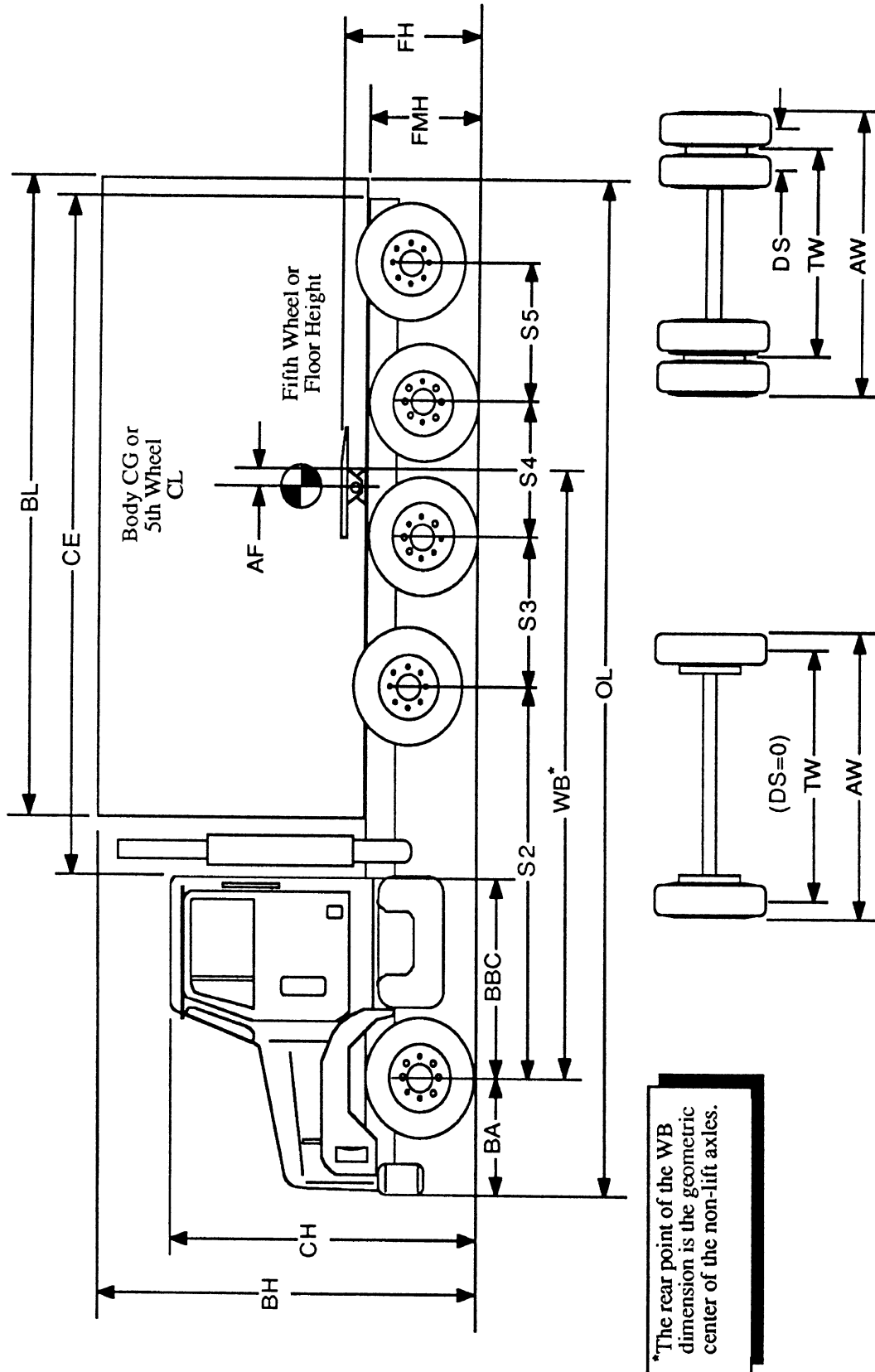

Figure I.1. Dimensions for Unit Trucks and Tractors

VEHICLE DEFINITION (Heavy Trucks — Unit and Articulated)

Semitrailers

General

Year _____ Make _____ Model _____ Mileage _____

VIN _____ Fleet No _____ GVWR _____

Status: Production Pilot Prototype
 Pre-prototype Development Pretest
 Component Experimental

Body Style: Van Liquid Tanker Dry Bulk Tanker
 Flat Bed Single Drop Drop Center

Options: Refrigeration Other _____

Loading _____

Major Dimensions†

BH _____ mm BL _____ mm BW _____ mm FH _____ mm

KSB _____ mm OH _____ mm PH _____ mm WB _____ mm

Mass

Tire Loads

Axle No. (from front): 1 2 3 4 5

Left Side: _____ kg _____ kg _____ kg _____ kg _____ kg

Right Side: _____ kg _____ kg _____ kg _____ kg _____ kg

Axle No. (from front): 6 7 8

Left Side: _____ kg _____ kg _____ kg

Right Side: _____ kg _____ kg _____ kg

† Figure II.1 identifies these and other dimensions.

Suspension No. _____

Includes Axle(s) No(s): _____

Make: _____ Model: _____ Load Rating, kg: _____

Style — Single axle suspensions

Leaf Spring Air Lift
 Other _____

Style — Multi-Axle Suspensions

Walking Beam Four Leaf Air Torsion Bar
 Other _____

Spring(s)

Make _____ Model _____

Multi-Leaf Taper Leaf No. of Leaves _____ Length, mm _____
 Air Torsion Bar Rubber Block
 Other _____

Remarks _____

Suspension No. _____

Includes Axle(s) No(s): _____

Make: _____ Model: _____ Load Rating: _____

Style — Single axle suspensions

Leaf Spring Air Lift
 Other _____

Style — Multi-Axle Suspensions

Walking Beam Four Leaf Air Torsion Bar
 Other _____

Spring(s)

Make _____ Model _____

Multi-Leaf Taper Leaf No. of Leaves _____ Length, mm _____
 Air Torsion Bar Rubber Block
 Other _____

Remarks _____

VEHICLE DEFINITION

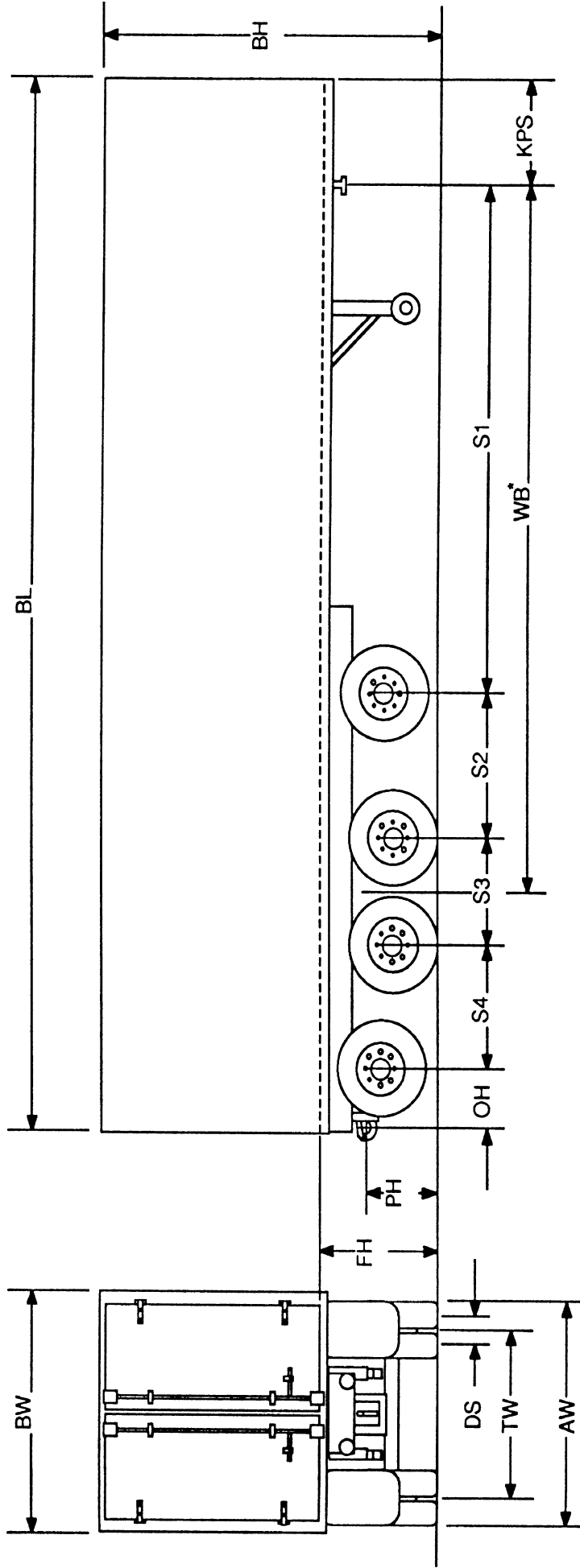

* The rear point of the WB dimension is the geometric center of the non-lift axles.

Figure II.1. Dimensions for Semitrailers

VEHICLE DEFINITION (Heavy Trucks — Unit and Articulated)

Converter Dollies

General

Year _____ Make _____ Model _____ Mileage _____
 VIN _____ Fleet No _____ GVWR _____
 Status: [] Production [] Pilot [] Prototype
 [] Pre-prototype [] Development [] Pretest
 [] Component [] Experimental
 Style: [] A-Dolly [] B-Dolly
 Other _____

Major Dimensions†

AF _____ mm OL _____ mm WB _____ mm FH _____ mm

Mass

Tire Loads

| | | | |
|------------------------|---------------|---------------|---------------|
| Axle No. (from front): | _____ 1 _____ | _____ 2 _____ | _____ 3 _____ |
| Left Side: | _____ kg | _____ kg | _____ kg |
| Right Side: | _____ kg | _____ kg | _____ kg |

Axles

| | | | |
|--|---------------|---------------|---------------|
| Axle No. (from front): | _____ 1 _____ | _____ 2 _____ | _____ 3 _____ |
| Spacing from pintle hitch or preceding axle (S2)†, mm: | _____ | _____ | _____ |
| Make: | _____ | _____ | _____ |
| Model: | _____ | _____ | _____ |
| Load rating, kg: | _____ | _____ | _____ |
| Axle Width (AW)†, mm: | _____ | _____ | _____ |
| Track width (TW)†, mm: | _____ | _____ | _____ |
| Dual spacing (DS)†, mm: | _____ | _____ | _____ |
| Self-steering: | [] | [] | [] |

† Figure III.1 identifies these and other dimensions.

Suspension

Make: _____ Model: _____ Load Rating: _____

Style — Single axle suspension

Leaf Spring Air Lift
 Other _____

Style — Multi-Axle Suspension

Walking Beam Four Leaf Air Torsion Bar
 Other _____

Spring(s)

Make _____ Model _____

Multi-Leaf Taper Leaf No. of Leaves _____ Length, mm _____
 Air Torsion Bar Rubber Block
 Other _____

Remarks _____

Brakes

Actuation

Air
 Hydraulic: Vacuum Asst. Hydraulic Power

Wheel Brakes

Axle No. (from front): 1 2

Make: _____

Disc:

Drum:

Disc or Drum size: _____

Wedge:

Wedge Angle, deg: _____

S-Cam:

Slack Length, mm: _____

Automatic Slacks:

Air Chamber Type: _____

Anti-lock:

Anti-Lock Make: _____ Anti-Lock Model: _____

Remarks _____

Tires and Wheels

Axle No. (from front): 1 2 3

Wheels

| | | | |
|--------------|-------|-------|-------|
| Make: | _____ | _____ | _____ |
| Spoke Style: | [] | [] | [] |
| Disk Style: | [] | [] | [] |
| Rim Size: | _____ | _____ | _____ |

Tires

| | | | |
|-----------------------|-------|-------|-------|
| Make: | _____ | _____ | _____ |
| Model: | _____ | _____ | _____ |
| Size and Load Range: | _____ | _____ | _____ |
| Tread Style: | _____ | _____ | _____ |
| Tread Condition; New: | [] | [] | [] |
| Half Worn: | [] | [] | [] |
| or Full Worn: | [] | [] | [] |
| Tread Depth, mm: | _____ | _____ | _____ |
| Pressure, kpa: | _____ | _____ | _____ |

 Taken: [] Hot or [] Cold

VEHICLE DEFINITION

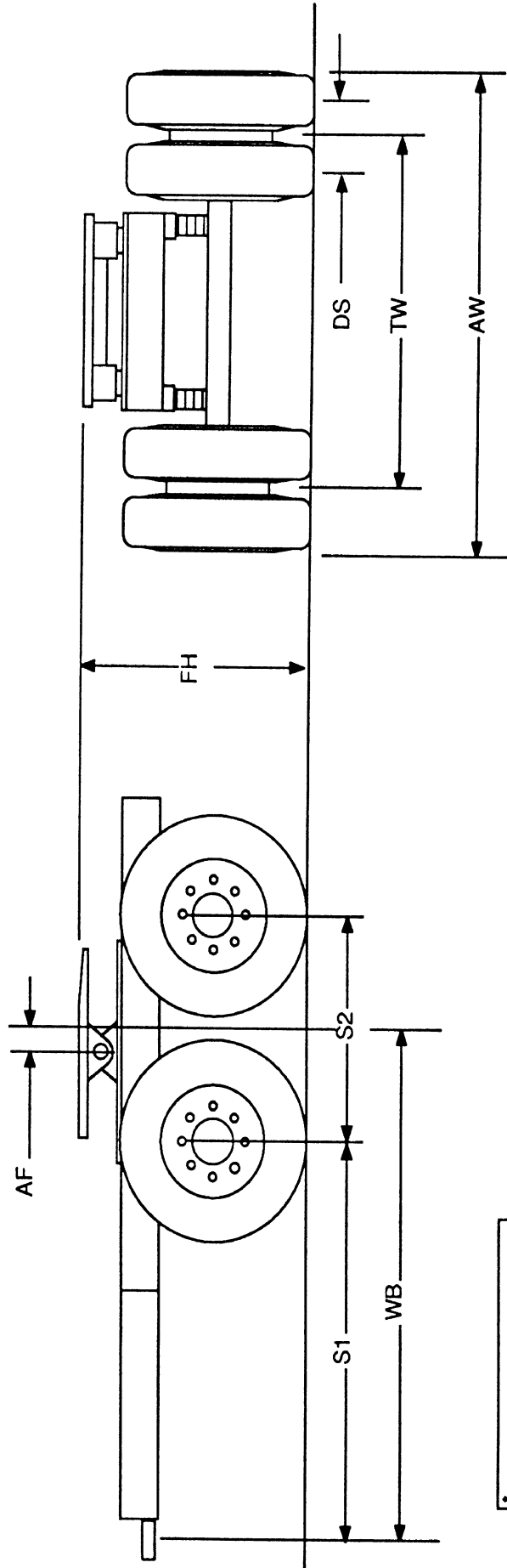

* The rear point of the WB dimension is the geometric center of the non-lift axles.

Figure III.1. Dimensions for Converter Dollies

VEHICLE DEFINITION (Heavy Trucks — Unit and Articulated)

Full Trailers

General

Year _____ Make _____ Model _____ Mileage _____

VIN _____ Fleet No _____ GVWR _____

Status: Production Pilot Prototype
 Pre-prototype Development Pretest
 Component Experimental

Body Style: Van Liquid Tanker Dry Bulk Tanker
 Flat Bed Single Drop Drop Center

Options: Refrigeration Other _____

Loading _____

Major Dimensions†

AF _____ mm BH _____ mm BL _____ mm BW _____ mm

FH _____ mm KPS _____ mm OH _____ mm PH _____ mm

WB _____ mm WBD _____ mm

Mass

Tire Loads

Axle No. (from front): 1 2 3 4 5

Left Side: _____ kg _____ kg _____ kg _____ kg _____ kg

Right Side: _____ kg _____ kg _____ kg _____ kg _____ kg

Axle No. (from front): 6 7 8

Left Side: _____ kg _____ kg _____ kg

Right Side: _____ kg _____ kg _____ kg

† Figure IV.1 identifies these and other dimensions.

Suspension No. _____

Includes Axle(s) No(s): _____

Make: _____ Model: _____ Load Rating, kg: _____

Style — Single axle suspensions

Leaf Spring Air Lift
 Other _____

Style — Multi-Axle Suspensions

Walking Beam Four Leaf Air Torsion Bar
 Other _____

Spring(s)

Make _____ Model _____

Multi-Leaf Taper Leaf No. of Leaves _____ Length, mm _____
 Air Torsion Bar Rubber Block
 Other _____

Remarks _____

Suspension No. _____

Includes Axle(s) No(s): _____

Make: _____ Model: _____ Load Rating: _____

Style — Single axle suspensions

Leaf Spring Air Lift
 Other _____

Style — Multi-Axle Suspensions

Walking Beam Four Leaf Air Torsion Bar
 Other _____

Spring(s)

Make _____ Model _____

Multi-Leaf Taper Leaf No. of Leaves _____ Length, mm _____
 Air Torsion Bar Rubber Block
 Other _____

Remarks _____

VEHICLE DEFINITION

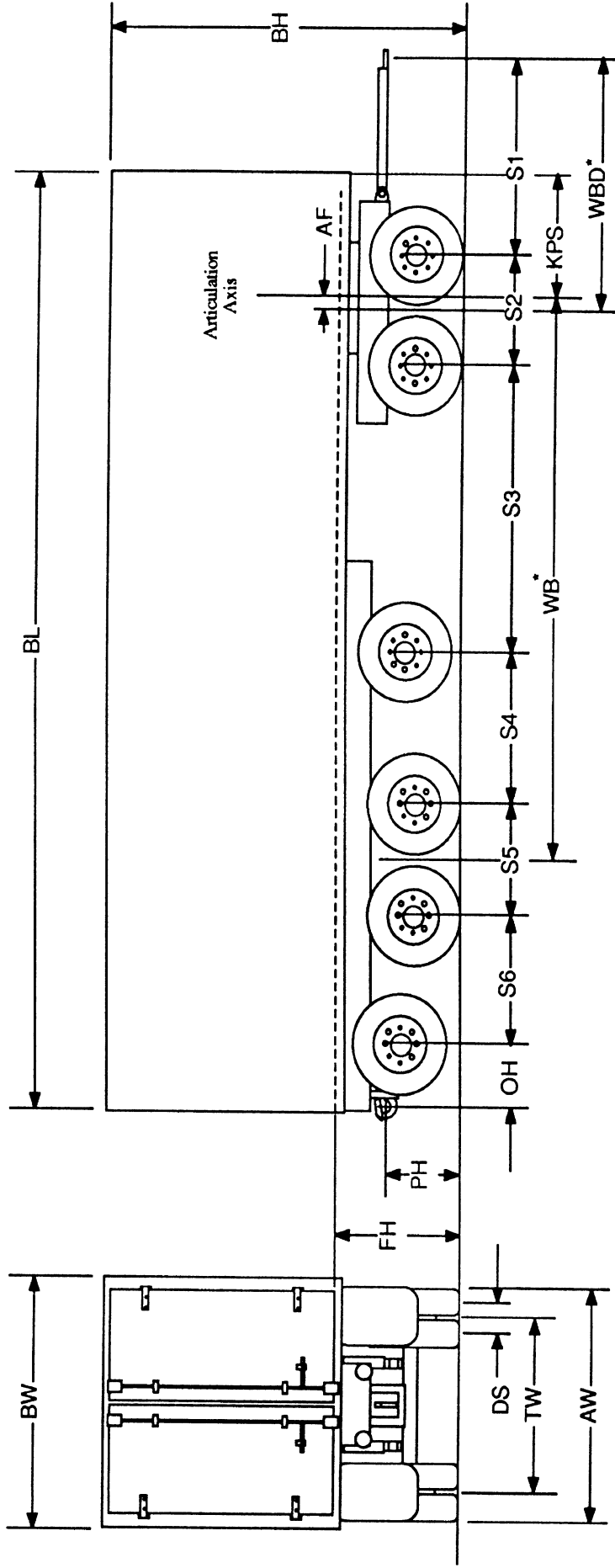

*The rear points of the WB and the WBD dimensions are the geometric centers of the non-lift axles.

Figure IV.1 Dimensions for Full Trailers

APPENDIX C

Outriggers are lateral extensions added to both sides of a unit to prevent it from rolling completely over. They are usually adjusted to allow the unit to roll beyond its "recoverable" roll angle before touching the ground and supplying a righting moment to prevent rollover. Figure C.1. offers some detail of the outriggers used by UMTRI to measure rearward amplification and high-speed transient offtracking of double and triple truck combinations.

Figure C.1. Outrigger Concept

Chains and Binders
(1 forward, 1 rearward)

Adjustment Bolts

