

## **Final Report for a Demonstration Structure for a 3D Holographic Sensor**

Steven Christman, David Doman, Ahmad Syazwan Bin Ahmad Kamal

University of Michigan ME450: Team 12

12/11/12

Sponsored by:



### **Abstract:**

**Coherix is a leading manufacturer of non-contact precision 3D measurement sensors and needs a demonstration structure to sell their new S150 3D sensor. A precise demonstration structure must be designed and built which can showcase the S150 and can be sold to customers across the globe to meet their metrology needs. The structure needs to move the sensor to four fixed points along the X-Y plane at a fixed height of 300 mm. The demonstration unit must allow the S150 to take high quality images with sub-micron accuracy.**

## Executive Summary

Coherix is headquartered in Ann Arbor and since 2005 they have expanded rapidly into one of the leading manufacturers of non-contact precision 3D measurement sensors. The company is well established in the automotive industry, supplying their products to most of the major automotive manufacturers and tier one suppliers. Coherix is looking to expand to provide sensors to smaller companies. To meet the needs of these companies, Coherix developed the S150 3D holographic sensor. This 35 pound sensor has a 150mm by 150mm field of view, and can measure with sub-micron precision.

Our project is to design and build a structure that can demonstrate the S150's functionality and flexibility. The S150 needs to be movable in the X-Y plane at a fixed height of 300mm. The sensor must also have the ability to be fixed at four points oriented in a 285mm square. Most importantly, the structure needs to give the sensor the ability to take quality and repeatable measurements. The entire structure must be extremely rigid to ensure that the system's natural frequency is more than 30Hz. There must be a minimum safety factor against yield of two. To ensure high quality images, the difference in the sensor's tilt angle cannot exceed  $0.2^\circ$  between any two locations. The sensor must be fixed in the X and Y directions with an accuracy of  $\pm 1$ mm. The demonstration unit must also protect the sensor from ambient light and wind which could affect the quality of the images.

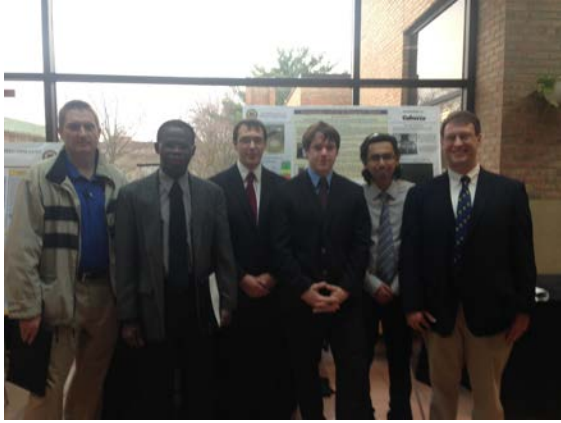
In order to create the optimal demonstration unit, we first did a functional decomposition on the project. For each sub-function, we brainstormed many ideas that could fulfill it. We used Pugh charts to determine the design that was the most ideal for each of the sub-functions. From there we create four prospective designs from which we selected an Alpha Design. The ball transfer concept was selected as the Alpha Design. From there we created a detailed CAD model of a refined version of the Alpha Design to be used in the finite element analysis.

Finite element analysis was conducted to verify that our design would meet all of the engineering specifications. It determined the maximum deflection of the beams, Von Mises stresses, natural frequency, and shock response of the demonstration unit. The analysis determined that the maximum deflection was 0.61mm and the maximum stress was 24MPa at 140lbs, both well below the requirements.

Our final design utilizes three commercial grade ball transfers that support the sensor frame that the sensor is mounted to. On the sensor frame there are three aluminum transfer plates that roll atop the ball transfers. Supporting the entire structure is a four legged structure constructed using 80/20 extruded aluminum. Acrylic on three walls and on top will prevent light and wind from affecting the sensor. To manufacture this design, we will be using mills, band saws, drill presses, water jet, and a laser cutter.

To validate our design, took the demonstration unit to Coherix to perform vibration testing as well as other tests. The vibration testing consisted of bolting our structure to a passive vibration isolation steel breadboard table, then striking the table with a rubber mallet to induce vibrations. A computer program plotted the resulting amplitude-frequency distribution. The change in tilt and environmental resistance were tested using the S150 itself. The sensor has a built in program that measures absolute tilt at a given point, and four undistorted images taken from our prototype is enough proof that our structure amply protects the system from ambient light and wind. Our validation tests proved that our demonstration unit passed all of the required specifications.

Though our prototype successfully passed all of the required tests, there are things that could be improved on it. Due to budget constraints, we had to use non-precision parts for major design components. This means that if more of these are produced, the results may not be the same for all of them. The final design could also be improved by using a more ergonomic handle bar. There are also some noise issues associated with the rolling of the bearings on the transfer plate, which can also be alleviated with the use of precision ball transfer units. In conclusion, we have designed an innovative demonstration unit for the S150 sensor that has successfully passed all the required engineering specifications, but there is still certainly room for improvement before moving into production.



Left to Right: Michael Mater(Coherix), Professor Kannatey-Asibu, Steven Christman, David Doman, Syazwan Kamal, Professor Krauss



Demonstration Unit for Coherix's new S150 3D Holographic Sensor



Demonstration Unit for Coherix's new S150 3D Holographic Sensor

## Table of Contents

### Main Report

Background of Coherix	5
Project Description	5
Customer Requirements	6
Engineering Specifications	7
Quality Functional Deployment	8
Concept Generation	10
Functional Decomposition	10
Concept Selection	11
Alpha Design Selection	15
Alpha Design	18
Engineering Fundamentals and Analysis	19
Engineering Design Parameter Analysis	20
Geometry and Bonding Simplifications	21
Static Analysis	23
Frequency Response	24
Shock Response	26
Final Design Description	30
Fabrication Plan	34
Inventory	35
Final Prototype Design	41
Experimental/Validation Plan	45
Design Critique	56
Recommendations	57
Conclusion	58
Acknowledgements	60
Literature Review	61
References	62

### Appendix

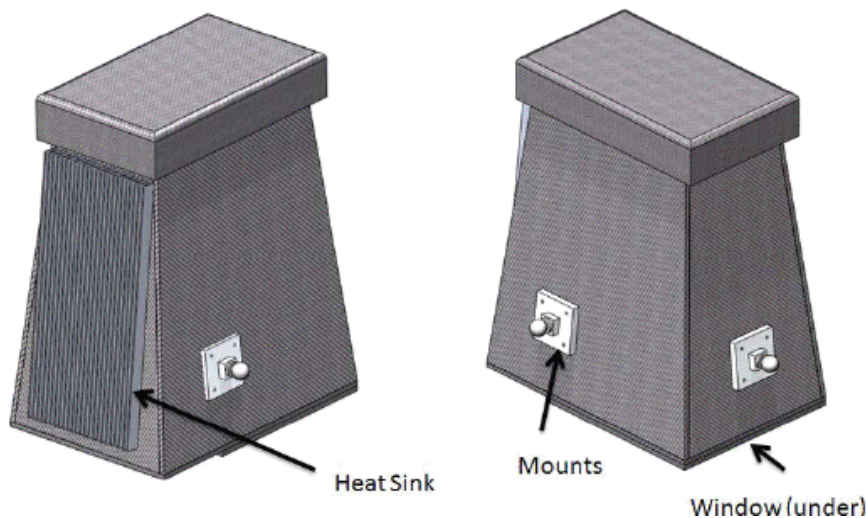
A. Bill of Materials	63
B. Engineering Change Notices	65
C. Design Analysis	75
D. Quality function Deployment	85
E. Concept Generation (Full List)	86
F. Engineering Part Drawings	87
G. Manufacturing Plan	106
H. Assembly Instructions	109
I. Team Bios	118

## Background of Coherix

Coherix is a leading manufacturer of precision 3-Dimensional holographic sensors. The company was founded in 2005 and has grown rapidly in the automotive industry. Coherix is a supplier to most of the major car manufacturers as well as many of the larger tier one suppliers. Their mission statement is “Our Mission is to become the world’s leading supplier of robust 3-D sensors and software.”[1]. their precision sensors allow companies to scan a metallic part and determine the surface conditions and see any imperfections down to  $0.1\mu\text{m}$ . The ability to measure an entire surface to sub-micron precision quickly is why Coherix will be successful in achieving their goal.

Coherix currently offers the ‘entire solution’ to their customer’s needs. They sell everything a customer would need to scan a part in a single package. These solutions are generally best for manufacturers who make larger parts, such as engine blocks, but can be prohibitively expensive to smaller companies who need precision 3D sensors. The major downside to this is that there are dozens of smaller companies for every large company. Coherix needs a product that can reach out to the smaller companies. To fill this void in the market, Coherix developed the S150 Sensor as seen in Figure 1 below. This sensor is the smallest sensor they make, which will allow their technology to reach many new customers.

**Figure 1:** Coherix S150 Sensor



## Project Description

Coherix developed their S150 sensor to reach out to smaller businesses. The S150 sensor weighs 35 pounds and will be mounted on three balls which can be adjusted to change the tilt. One of the balls will rest on a flat surface, one ball on a V-Groove, and one in a cup. This will constrain the sensor in all directions except upward in the positive Z-direction.

Our task is to design and build a demonstration structure to hold and move the S150 sensor. The sensor and structure will be available globally through value-added resellers as a solution to their customer’s metrology needs. The structure must be mobile, simple and robust to take to a

customer and allow them to experience the sensor. The structure will be designed to meet a broad spectrum of needs so nearly every company can see the usefulness of the product. Through the reseller, the customer will be able to modify the structure in order to meet their unique needs. For example, if the customer wants a structure that can be operated robotically, the value added reseller may attach electromechanical systems to accomplish this. While other customers may want a reinforced structure that would be able to take more abuse.

### **Customer Requirements**

Coherix wants a structure that can be used to demonstrate the capabilities of the S150 sensor. The structure must move the sensor along the X-Y plane at a fixed height. The face of the sensor is at a fixed height of 300mm. Perhaps most importantly, this structure should allow for a lot of repeatability. In other words, the structure should be able to let the sensor give the same quality results over and over again. The demonstration unit would prove to be quite useless if after a few runs the supports start to deflect and thus distort the precise images, which means the customers would be less than impressed. Additionally, smaller companies often have floor space constraints, meaning that the structure must be mobile enough that the customer can move it if necessary. There are two cables associated with the sensor itself: a cable attached to a 24V DC power supply, as well as an Ethernet cable that will send information from the sensor into a nearby computer. The structure should provide a system that can keep these cords out of the way of both the sensor and any moving parts, so as to avoid any damage. Finally, the structure should have an accurate positioning system for the X and Y coordinates of the sensor. Since many parts to be scanned will have dimensions much larger than the sensor's 150mm by 150mm field of view, up to four images will be taken and stitched together. The area that can be scanned will consist of four areas, each 150mm x 150mm with a 15mm overlap. In order for this to be done, the operator has to know exactly where the sensor is for each image taken within +/- 1mm in the X and Y directions.

There are also some important criteria the demonstration unit should meet beyond its actual functions. In particular, it is important that the unit is safe to use and to be around. This means we should avoid sharp edges, pinch points on moving parts, and the entire structure tipping over and falling off of the working surface. Personal injuries or damage to the sensors could prove very costly to any involved parties. In addition to safety concerns, it should be a relatively simple structure, devoid of any complicated parts such as hydraulic motors or complex pulley systems. Anyone should be able to use the apparatus, so that a technician does not need to be present every time the sensor is to be used, which also brings in unnecessary costs. The simplicity of the structure also takes into account that it should be made with as many "off the shelf" parts as possible, while avoiding long lead items. Since this product will be used globally, it is important that any oversea companies can easily go to McMaster-Carr or another large supply company and buy all the parts necessary without first sending them to a shop to be machined first. This could cause the cost of manufacturing to be significantly more expensive. Items with long lead times can also be problematic, since there will be many of these structures produced on a global scale. Finally, the structure should be visually appealing, as well as have an attractive price tag. As with any product in a market economy, there is always an ulterior motive beyond function, namely profit. The value-added resellers and actual customers will obviously be more likely to buy a nice looking apparatus. Coherix wants to be able to sell these units at a price that clients will deem reasonable, while still making a large enough profit to pay for any overhead costs.

## Engineering Specifications

Based on our customer requirements, there are several engineering specifications that we need to meet. Coherix determined most of these specifications by the setting the boundaries beyond which it would compromise the quality of the scanned image. The table below lists the specifications to which we must design our structure.

**Table 1:** Engineering Specifications and Target Values

<b>Engineering Specifications</b>	<b>Target Values</b>
Deflection of Sensor	< 5mm
Structure's first natural frequency	> 30Hz
Safety factor against yield	> 2
Weight of demonstration unit not including the sensor	< 35lb
Accuracy in rotation angle of sensor	$\pm 0.5^\circ$ about Z axis
Tilt of Sensor	$0.5\text{mm} > \Delta Z$ of any 2 points on sensor
Accuracy in X-Y directions of sensor	$\pm 1\text{mm}$
Accuracy in Z direction of sensor	$\pm 5\text{mm}$
Footprint of Structure	< 914mm x 914mm
Scannable Area	> 285mm x 285mm
Protection from Air Currents and ambient light	Structure must be enclosed to prevent air flow and ambient light

The structure will be mounted to a granite table that is designed to dampen vibrations greater than 30Hz. Thus, the natural frequency of the structure must be higher than 30Hz in order for the table to most effectively reduce the vibrations. We have determined that any part on the structure must have a minimum safety factor against yield of two against any foreseeable forces, such as the full weight of the structure being applied at any given point on the structure. Other forces include the force exerted on the structure when the sensor is moving and is abruptly stopped. This will give the customers some room to modify the structure by adding extra components without worrying if the structure will fail, such as electromechanical drive systems or more measuring devices. In order to accommodate the possibility of adding extra components, the structure will be designed to hold an extra 35lbs, for a total of 70lbs including the sensor. Not all customers will treat the structure the same, and this safety factor gives a cushion for customers who treat their equipment a little rougher. We determined that the weight of the structure must be less than 35 pounds, the weight of the sensor. The structure must be moveable by a single person and many workplaces have a limit on the weight a person lift for safety reasons. The sensor and structure should never be moved together, due to the risk of the sensor falling off. If the sensor and the structure weight the same, there will be no additional risk of injury to employees. Rotation about the Z-axis must be no more than  $0.5^\circ$ , any greater and the computer will not be able to stitch multiple images together. A difference in height between any two points on the face of the sensor must be no greater than 0.5mm. This is equivalent to a tilt of  $0.2^\circ$ . The tilt of the sensor cannot be more than  $0.2^\circ$  between any of the four locations. The tilt of the sensor significantly affects its performance because the sensor relies on a laser reflecting off the part and back into the sensor. Stitching of multiple images requires a 10% overlap which is 15mm. The accuracy in measuring of the X-Y position must be at minimum  $\pm 1\text{mm}$ , on the same order

of significance as the required overlap. This means that required overlap in the system must not allow for the tolerances to result in an overlap less than 15mm. Accuracy in positioning of the sensor in the Z-direction requires  $\pm 5$ mm because 5mm is the maximum difference between two points on a part the sensor is measuring. The footprint of the structure must be no more than 914mm by 914mm because that is a standard size of granite tables. Any larger and the structure would not fit. The sensor must be able to be fixed in four locations and scan an area of 285mm x 285mm. This will fit most cylinder heads for inline four engines. Air flow and ambient light will distort the image, thus we must create a system where the airflow and ambient light are blocked. The airflow must either be a constant speed or as still as possible. The ambient light allowed depends on the part being measured, brighter parts have a higher allowable light that can reach the sensor face. Initially there was an engineering specification that required the vibration amplitude to be less than  $0.1\mu\text{m}$  at the natural frequency. Under the direction of Coherix, we have removed this specification and no longer need to satisfy it in order to produce a successful demonstration unit. The reason for this change is primarily because this is a system wide specification. System wide means it includes many other parts beyond just our demonstration unit, such as the metrology table, the part fixture and the part itself. Since we cannot control the other factors; nor can we precisely determine the effects that a part fixture or unknown table will have.

### **Quality Function Deployment**

One list of customer requirements and another of engineering specifications doesn't exactly present a meaningful approach to the overall importance of the responsibilities we are dealing with. In order to effectively evaluate the balance between the two, we used a quality function deployment, or QFD. This can be found in Appendix D, page 85. Employing a QFD helped us to understand which of our engineering specifications would be most important to consider during the design and manufacturing phases.

Each of the customer requirements was assigned a relative weight value, ranging from 1-10. The more important requirements were given higher values. Repeatability was considered the most important requirement. This is because if it is not, and after a while the support bars begin to deflect or the vibrations cause differences, the images will begin to lose their accuracy, which renders the entire product useless. Safety, simplicity and a fixed position in the Z direction were considered equally important and given the second highest weights. Safety is very important, but it is not a defining factor in the practicality of the device. The simplicity of the device is stressed to a high degree because the structure will be available globally and will need to be easy to use and maintain anywhere. The fixed height is also very important for the same reason as repeatability, but to a lesser degree. Also, a measure to keep the sensor face from tilting is equally important as the previous three. This is because the functionality of the structure directly depends on the tilt of the sensor. Lowering the overall manufacturing cost is also important because Coherix would like to maximize their profit on each item. However, it is considered less important than the above requirements because the cost of the structure should only be a small fraction of the sensor's price. The sensor will have a cost on the order of tens of thousands of dollars, while our structure should be made for under our budget of \$400.

Less important requirements include the structure's cable management system, the mobility of the structure, and the accurate X-Y positioning system on the structure. As far as the mobility of



the structure goes, it won't be moving from place to place very often, so as long as it is able to be moved, it's not crucial that it is easily moved. The positioning system is needed, but its accuracy is not very necessary, since it does not need to be more accurate than  $\pm 1\text{mm}$ .

Another important factor to consider is how the technical requirements affect each other. For instance, if we use parts that are more readily available, it is obvious that the lead times of the parts will generally decrease. Since both changes are moving toward the requirements' targets (minimizing lead time and maximizing availability), it is noted as a strong positive relation, and marked with a "++." Conversely, as the weight of the structure decreases and all other parameters are held constant, the structure will require less of a moment to tilt. For this reason, it is noted as a strong negative relation and marked with a "--." This process was done for each parameter evaluated against each of the others, using the scale from strong negative to strong positive correlations, and can be seen on the QFD in the triangular portion above the technical requirements.

We established that the vibration amplitude of the structure was affected by its size and weight, as well as the unit's natural frequency. The structure can be thought of as an active mass-spring-damper system, where the stiffness and length of the beams, as well as the weight of the beams affect the various spring and damping constants. Stiffer beams give higher analogous spring constants. This system can then be analyzed to obtain the governing second order differential equation, which will give the natural frequency and amplitude of vibration. The natural frequency is also dependent of the size and weight of the structure.

Both the accuracy in the Z direction and accuracy of rotation angle of the sensor are influenced by the deflection of the horizontal support beams. The Z direction is especially affected because when the load is in the center of a long beam, there could be significant deflection, which means the fixed height loses accuracy compared to a perfectly rigid beam. In other words, a more rigid support means more accuracy in the height of the sensor. Accuracy in the rotation angle of the sensor is affected in the same way, but not quite as significantly.

Using these weighted requirements, we then evaluated the influence of the engineering specifications on each requirement, which then provided us with a rank of importance of each of the specifications. The most important specification turned out to be minimizing the deflection on the horizontal beams. This makes sense because as mentioned before, the higher these deflections are; the further the structure is from being useful. The next parameter in terms of importance is keeping the demonstration unit's natural frequency above 30Hz in the Z-direction. These are also sensible rankings for the same reason stated above: if the specifications are not met, the sensor will not give usable images. The least important specs are the weight of the structure and the structure size. The weight of the structure should be minimized, but it has very little to do with making the sensor work better. In fact, with larger, heavier beams, the strength will be higher and thus the safety factor, deflections and vibrations are all improved. This means the overall functionality will be better.

## **Concept Generation**

To generate concepts for a demonstration unit for the S150 sensor we created a functional decomposition. This allowed us to examine the engineering specifications and determine a set of functions the demonstration unit must fulfill in order to be successful. The purpose of the demonstration unit is to provide a stable platform for the S150 Sensor to move along an X-Y plane 300mm above a flat surface and take high quality 3D images at four fixed locations. Our functional decomposition can be seen below.

### **Functional Decomposition**

1. Stabilize Structure on Flat Table
  - a. Place structure on table
  - b. Secure structure to table
2. Constrain Sensor to Structure 300mm Above Table
  - a. Fix sensor to structure in negative Z-direction at a given height
  - b. Fix sensor to structure in X and Y-directions
3. Safely Transport Sensor Along the X-Y plane
  - a. Exert force to move sensor
  - b. Maintain force to keep sensor in motion
  - c. Decelerate sensor to stop at fixed locations
4. Fix Sensor at Four Possible Locations
  - a. Lock sensor in each position
  - b. Display current position of Sensor
  - c. Unlock sensor after picture is taken
5. Ensure Sensor Takes High Quality Images
  - a. Minimize ambient light on part
  - b. Reduce airflow between part and sensor
  - c. Make sure vibrations greater than 30Hz
6. +Prevent the Sensor from Rotating or Tilting
  - a. Measure tilt of sensor about the X and Y axes
  - b. Measure rotation about Z-axis of sensor
  - c. Alert user if sensor is out of tolerance in tilt or rotation
  - d. Adjust tilt and rotation of sensor to usable levels

Those are the six major functions of the demonstration unit that must be met if the demonstration unit can be successful. Using the functional decomposition as a guide, we were able to brainstorm concepts that would meet each individual function. We separated the project into six components, the support structure, the sensor movement; a method to fix the sensor in location, a method to ensure the sensor is accurately in location, a measuring system for the tilt of the sensor, and protecting against the environment.

After we created the six major functions of the demonstration unit we all generated concepts individually. As a group, it would be more likely some people would be less comfortable to voice their opinions. We came together as a team and listed all the concepts we each had produced. Discussion of all the ideas gave every member of the team the chance to fully understand all the ideas and inspired some new concepts. A full list of our ideas for each function can be found in Appendix E on page 86.

## Concept Selection

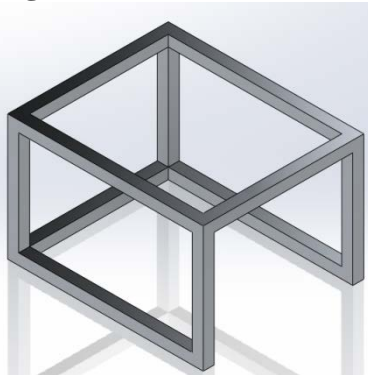
In order to narrow the field, we first threw out the implausible ideas using a feasibility analysis and technological readiness. These ideas were deemed implausible if they would not meet our engineering specifications or if the technology needed to complete the task was either immature or does not exist. Some of these ideas included the use of thermal expansion to move the sensor, black holes, and magnetic levitation to lift the sensor. After narrowing down the ideas for each function, we created Pugh charts to compare the ideas against each other. A datum was selected for each function and every concept was scored against it on a scale of 1-5. Each concept was given a given a higher score if it was better than the datum and a lower score if it was worse.

**Support Structure:** In order to evaluate the support structure concepts, we decided on four design criteria to compare the ideas. The criteria were rigidity, the resistance to deformation under load; stability, the resistance to tipping over; mass, the weight of the structure; and accessibility, the ability to place a part inside the structure. Rigidity was the most important criterion because deformation can greatly affect the quality of the 3D scan. Table 2 below compares the five concepts to each other with a four legged structure being the datum. The winner of the Pugh chart was the horseshoe structure, as seen in Figure 2.

**Table 2:** Pugh Chart comparing the support structures.

Design Criteria	Weight	Design Concepts				
		4 legged	3 legged	Cube	Horseshoe	Cantilever Arm
Rigidity	45	3	2	4	4	1
Stability	35	3	3	4	4	2
Mass	10	3	4	2	2	3
Accessibility	10	3	3	2	3	4
<b>Total</b>	100	300	265	360	<b>370</b>	185

**Figure 2:** Horseshoe Structure



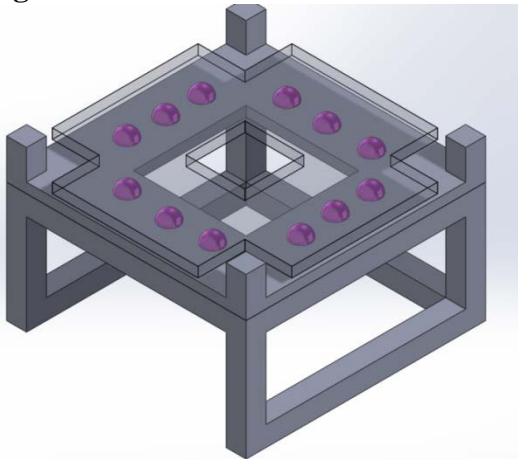
**Mechanism to Move the Sensor:** The mechanism to move the sensor is responsible for moving the sensor into the four locations on the X-Y plane. Six design criteria were decided on to evaluate the concepts. In order of importance, they are rigidity, ease of use, how easily any operator could operate the mechanism; manufacturability, the simplicity in manufacturing; maintainability, the ease of maintenance; price; and safety, the ability for an operator to use without risk of injury. Rigidity is the most important, followed by ease of use. The ease of use is

second because the demonstration unit must be easy enough to use that anyone with little to no training could operate it. Table 3 below compares six designs with the standard X-Y table being the datum. This was chosen to be the datum because Coherix is currently developing a test structure using this design. X-Y tables are the most common method to move items on the X-Y plane, however, most are not open frame which is required for this application. Open frame X-Y tables are generally designed for microscopes and are much smaller. The ball transfer scored the highest because it is more rigid than the standard X-Y table and it was also safer and easier to manufacture. Figure 3 shows the initial ball transfer concept where the top plate rolls atop twelve balls.

**Table 3:** Pugh Chart comparing the mechanisms to move the sensor

Design Criteria	Weight	Design Concepts					
		Standard X-Y Table	Independent Axis X-Y Table	Cantilever Arm	Cart	Ball Transfer	Tripod
Rigidity	30	3	4	1	3	4	3
Ease of use	25	3	3	2	2	3	3
Manufacturability	15	3	2	2	4	4	3
Easy to maintain	10	3	3	3	3	3	3
Price	10	3	3	2	4	3	4
Safety	10	3	3	3	1	4	3
<b>Total</b>	100	300	315	190	280	<b>355</b>	310

**Figure 3:** Ball Transfer on the Horseshoe structure



**Fixing the Sensor in Location:** The demonstration unit requires the sensor to be locked in place before the sensor can take any images. Three design criteria were selected to compare the five concepts. They were repeatability, the ability to lock the sensor in the same place over and over; robustness, the ability for the locking mechanism to resist damage during repeated use; and ease of use. Repeatability was the most important factor because the operator needs to know that the sensor is locked in the same position every time. Table 4 on the following page compares the five concepts with a latch, similar to one on a toolbox, as the datum. This was chosen as the datum because it is a common method of fixing two parts together. Pins scored the highest on this Pugh chart. The pins would allow the user to align two holes and insert a pin preventing the

sensor from moving. Although the pins scored the highest on this Pugh chart, we have decided to revisit this decision. After revisiting our decision to use pins, we were able to design a system to fix the sensor and check the location without adding any more parts to the design. As the sensor and sensor frame roll on top of the ball transfers, the balls will roll beneath holes in the flat plate at certain locations. When the ball rolls beneath the hole, the plate and sensor will drop down on the ball, locking it in position.

**Table 4:** Pugh chart comparing the methods of fixing the sensor in locations

<b>Design Criteria</b>	<b>Weight</b>	<b>Design Concepts</b>			
		Latch	Toggle Clamp	Pins	Drop into Position
Ease of use	25	3	3	3	5
Durability	20	3	3	3	2
Repeatability	30	3	3	4	4
Complexity	25	3	4	3	5
<b>Total</b>	100	300	325	380	<b>410</b>

**Method of Checking the Location of the Sensor:** Checking the location of the sensor is necessary to ensure that when it is locked in place that the sensor is with 1mm of the desired location. Five design criteria were decided upon to judge the concepts. They were repeatability, durability; simplicity, the complexity of setting up the system and using it; precision, the capability to measure within the tolerance; and the price of the system. Repeatability was weighted the most, because the operator needs to be sure it measures in the same location every time. Hard stops were chosen as the datum because this is a very simple and cheap way to measure whether or not a part is in a specific location. Table 5, on the following page, compares the seven concepts to the datum. The same pins selected for fixing the position of the sensor were also selected as the best method of checking the location. We are currently revisiting this decision because we believe it was biased. As mentioned above about fixing the sensor, we have decided to go with the same method of having the balls mate with holes in the plate to check the location of the sensor.

**Table 5:** Pugh Chart comparing the concepts for checking the location of the sensor

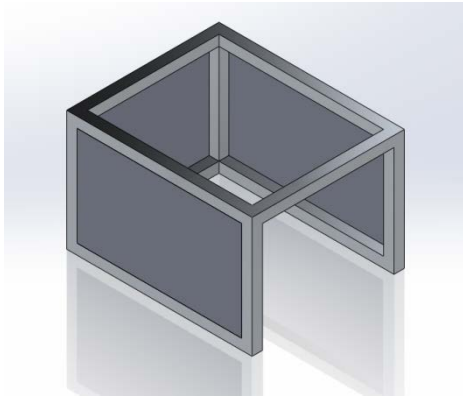
Design Criteria	Weight	Design Concepts				
		Hard Stops	Laser	Go/No-Go	Ruler	Drop into Position
Simplicity	20	3	2	2	3	5
Repeatability	25	3	4	4	2	4
Precision	20	3	4	4	1	3
Price	15	3	1	2	4	5
Robustness	20	3	3	3	5	2
<b>Total</b>	<b>100</b>	<b>300</b>	<b>295</b>	<b>310</b>	<b>290</b>	<b>375</b>

**Protecting Against the Environment:** To ensure that high quality images are taken, the sensor must be protected against ambient light reaching the face of the sensor and air currents between the sensor and the part. We chose five design criteria to compare the four design concepts against the datum, a hard case. The five criteria are protection against wind, protection against ambient light, mass, price, and ease of use. Table 6 below evaluates the four design concepts. Based on the evaluation, a hard case was determined to be the best concept because all the other concepts had at least one category where it scored low, while the hard case did not. Figure 4 on page 15 shows the hard case on one of the designs.

**Table 6:** Pugh chart comparing the concepts of protecting against the environment

Design Criteria	Weight	Design Concepts			
		Hard Case	Folding Curtains	Blinds	Shutters
Protection against wind	40	3	2	1	3
Protection against light	35	3	3	2	3
Mass	10	3	4	3	2
Price	10	3	4	2	2
Ease of use	5	3	3	2	3
<b>Total</b>	<b>100</b>	<b>300</b>	<b>285</b>	<b>175</b>	<b>280</b>

**Figure 4:** Hard Case mounted on the Horseshoe structure

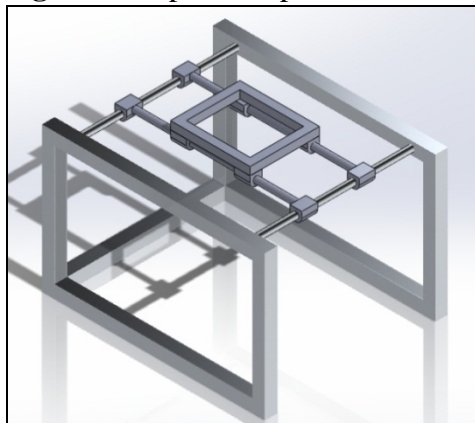


### **Alpha Design Selection**

The concept selection process of the individual functions provided us with several concepts that would satisfy all of the engineering specifications. Using a combination of the highest scored concepts and some of the lower scored concepts, we decided upon four final Alpha Design Prospects. The four designs are named for the method to move the sensor, since they all utilize a different method, and are numbered 1-4.

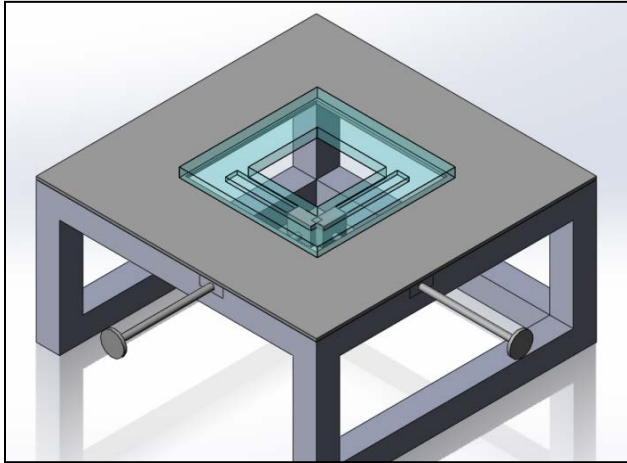
The standard X-Y table, concept number one, demonstration unit can be seen in Figure 5 below. This design was chosen because Coherix is currently developing a structure using this technology. We wanted to compare all of our concepts to the design that Coherix is developing. This design utilized the horseshoe structure, pins, digital level, and a hard case. The standard X-Y table would be able to meet the customer requirements in rigidity, safety, and durability by using hardened steel rails and linear bearings. Measuring the location of the sensor and the tilt would be simple to do; however, adjusting the tilt would more difficult to do than in other concepts. In order to adjust the tilt of the rails, they would need to be on moveable supports, which could compromise the rigidity of the structure. The open nature of the rails would also make it difficult to ensure no ambient light or wind would reach the part from the top. The overall cost of the system, if using the ideal materials, would extend beyond the \$400 budget. The high precision required for this design cost approximately \$100 per rail, which is a quarter of our overall budget.

**Figure 5:** Alpha Prospect #1: Standard X-Y Table



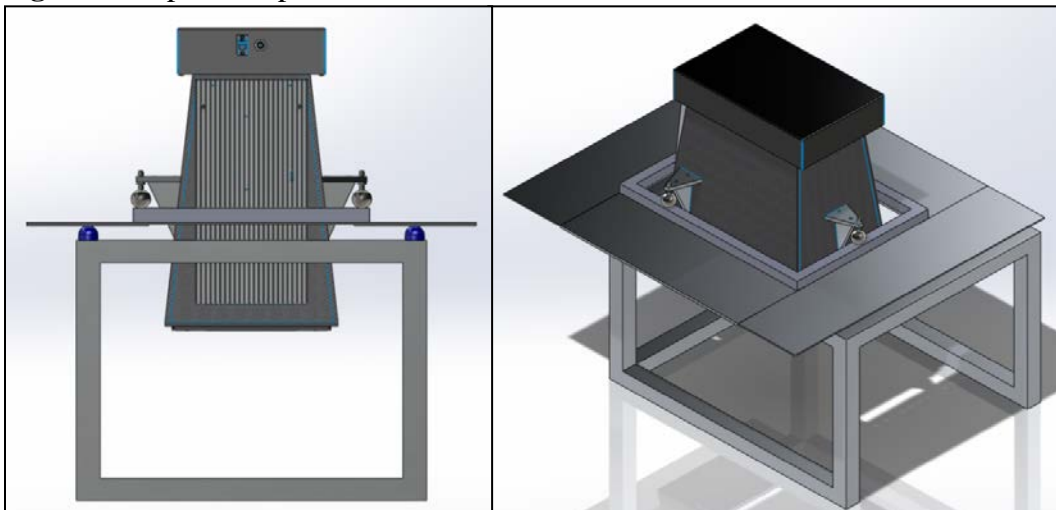
The independent X-Y table, concept number two, can be seen in Figure 6. This idea also utilized the horseshoe structure, pins, digital level, and a hard case. The independent X-Y table has advantages and disadvantages over the standard X-Y table. This design has the ability to be more rigid than standard X-Y table due to the fact that the plate that the sensor sits on will be supported along the entire perimeter of the viewing area. It will also protect against ambient light and wind better because of the large plate that the sensor rests on. This large plate will cause this design to be more difficult to manufacture. The large plate would be approximately 700mm x 700mm and would need to laser cut or on a water jet.

**Figure 6:** Alpha Prospect #2: Independent X-Y Table



The ball transfer plate, concept number three, can be seen in Figure 7 below. This idea also utilized the horseshoe structure, pins, digital level, and a hard case. The ball transfer design will be more rigid than the standard X-Y table because it will be easier to reinforce the plates that contact the ball bearings. The ball transfer design is easier to protect against the environment because the large plate that the sensor sits on will block most of the light. If we are able to use multiple smaller plates of aluminum, we will be able to cut down on the overall price of the design and increase the manufacturability. If the plate that rests on the balls is aluminum, then it will wear down and be damaged over time.

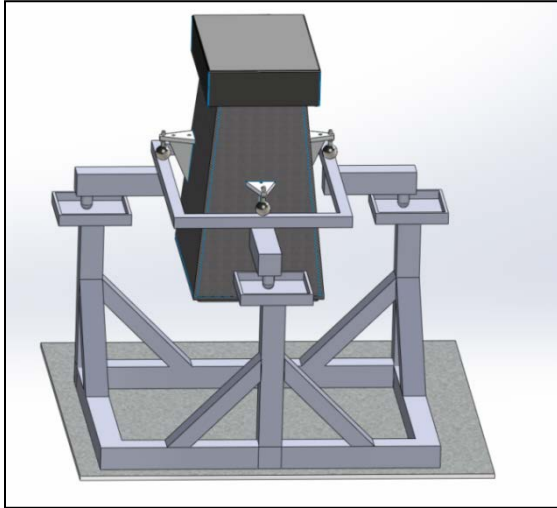
**Figure 7:** Alpha Prospect #3: Ball Transfer Plate





The tripod design, concept number four, can be seen in Figure 8 below. It utilizes a structure that is a combination of the three legged structure and the cube. This would provide the tripod with the most rigidity and stability. It would use a hard case, hard stops to locate the sensor, and a digital level. The tripod has an advantage over the other designs in that it is supported on only three points, meaning it is statically determinate. The tripod would also be more difficult than the other designs to fix in position accurately.

**Figure 8:** Alpha Prospect #4: Tripod



After deciding upon the four concepts, we created a Pugh Chart to compare the designs against each other and the datum, the standard X-Y table. The Pugh Chart can be seen in Table 8.

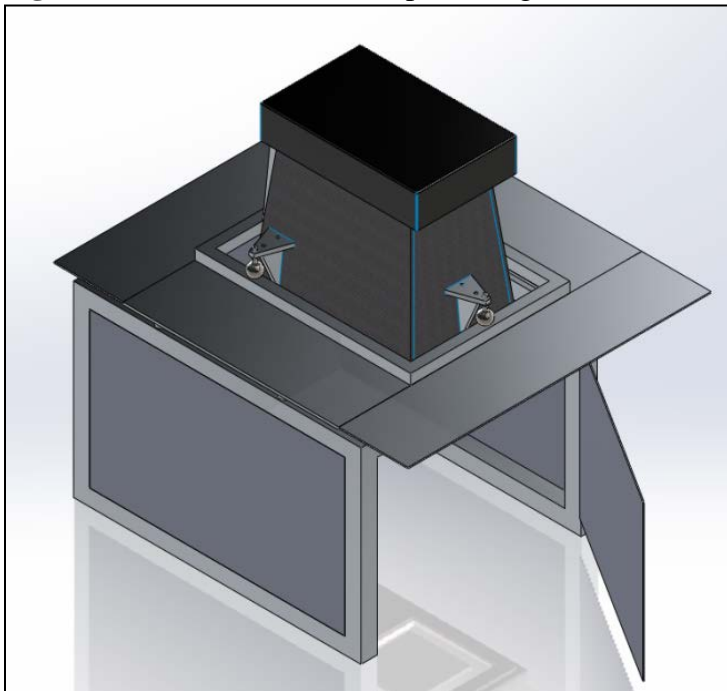
**Table 8:** Pugh Chart Comparing the Alpha Design Prospects

Design Criteria	Weight	Design Concepts			
		Standard X-Y Table	Independent X-Y Table	Ball Transfer	Tripod
Rigidity	20	3	4	4	4
Accuracy in Measuring Tilt	15	3	3	4	3
Safety	15	3	2	4	3
Protection Against Environment	12.5	3	3	4	4
Manufacturability	10	3	4	4	3
Cost	10	3	3	3	3
Accuracy in Fixing Position	10	3	3	2	2
Durability	7.5	3	3	2	2
<b>Total</b>	100	300	322.5	350	312.5

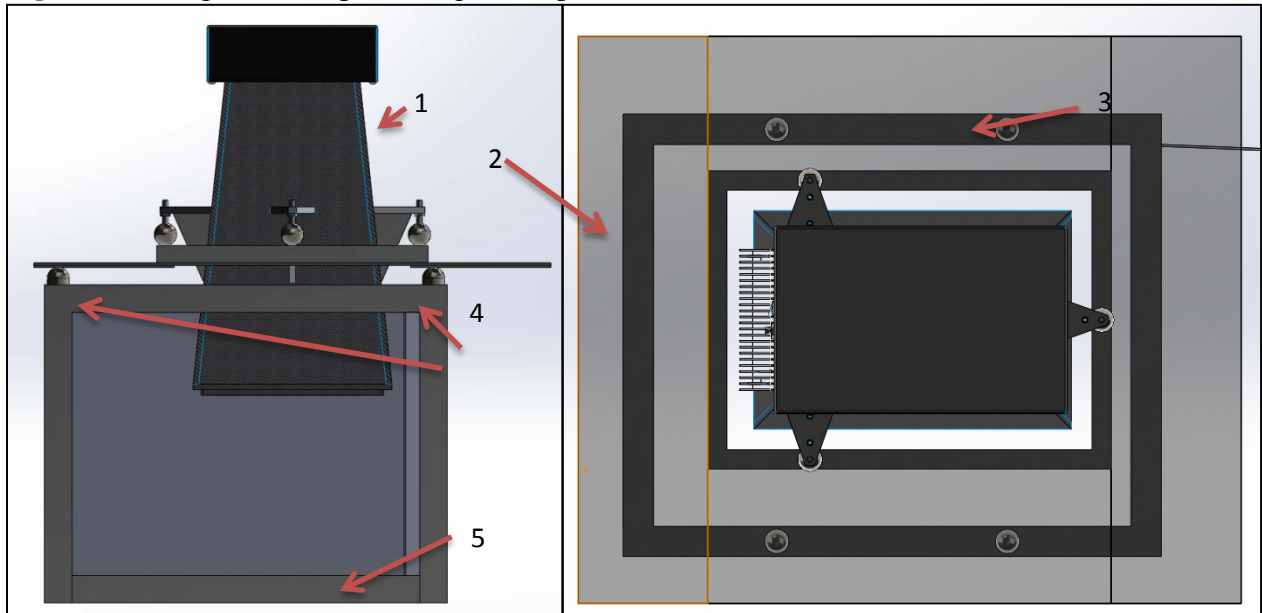
## Alpha Design

The ball transfer plate concept was chosen to be our Alpha Design by the Pugh Chart in Table 8 on the previous page. The overall design can be seen in Figures 9 and 10 below. The main functional concepts in this design are the horseshoe structure, the ball transfer plate, the pins to both secure and locate the sensor, the digital level, and the hard case. The overall concept is still in the design phase and will evolve the deeper we look into it. The diagram in Figure 10 shows two views of the sensor with parts labeled with a number to illustrate how they interact with each other. We currently have the S150 Sensor (1) resting on a frame (2) that is attached to two flat plates (3). The plates rest on four ball transfers (4) that allow the sensor to move in any direction on the X-Y plane. Everything is held in the air by the horseshoe support structure (5) In order to both fix the sensor in location and know it is in the correct position, the ball transfers will mate with holes in the plate and fall into position. This design allows for no extra parts, only four holes drilled into one plate and four slots drilled into another. The digital level, also not shown, would be placed atop the sensor when it is location to determine the tilt of the sensor. The digital level would first be calibrated to the granite table surface and then used to determine if the sensor tilts more than  $0.2^{\circ}$  between any two locations. This digital level would not be actively measuring the sensor, but instead would be used periodically to ensure the sensor is still within specification. If the sensor is determined to be out of tolerance, the four balls would be adjustable via screws to fine-tune the tilt of the sensor. The hard case, as seen in Figure 9 on page 22, will be black to absorb ambient light and be constructed of a thin, light weight plastic. The horseshoe structure will most likely be manufactured from 80/20 extruded aluminum. This will offer high rigidity due to the high rigidity while keeping the weight low.

**Figure 9:** Isometric View of Alpha Design



**Figure 10:** Diagram of Alpha Design with parts labeled



### **Engineering Fundamentals and Analysis**

In order to effectively design and build this demonstration unit, we must first apply knowledge from several different areas of engineering studies. We must consider any forces acting both on the structure from surroundings and within the structure, as well as any consequences these forces must have. This can include vibrations, deformation, and an impulse on the sensor, all of which can be harmful to the structure's functionality if large enough.

Perhaps the most important of these engineering fundamentals to consider is solid mechanics. We need to take into account the reaction forces from the table onto the structure, the forces between support beams, the force from the weight of the sensor and beams, and many others. These forces create stresses in the beams which may result in deformation if they are too great, and deformation in the Z direction must be less than 5mm. In such a precise setup, even a small amount of deformation could be devastating to the effectiveness of the sensor. We must also use the notion of static determinacy to accomplish the required precision. A three-legged table is fully constrained and thus statically determinate, but we conferred that three legs would not be good in terms of overall balance of the structure. Three legs would be more susceptible to tipping over than a horseshoe or four-legged structure. It would have also made the manufacturing process more difficult in terms of adding walls to block out light and wind. It is obvious that a four-legged table will wobble if all the legs aren't exactly the same height. Less obvious, however, is the effect of horizontal beams connecting the bottom of the legs, as can be seen in the "horseshoe" structure of the alpha design. Any wobble will affect the amount of tilt in the sensor, which must remain within the very narrow margin of  $0.2^\circ$ .

Another important fundamental to use in the design process is the mechanical behavior of materials. Fatigue stress and failure should definitely be considered when we are selecting materials to use for the parts that take on heavy loads, such as the ball bearings that hold up the sensors. We must also determine the safety factor on the support beams and the moving plate,

which is most accurately, determined using the Von Mises stresses. The weight on the vertical support beams will cause some strain, which could potentially be problematic if they are large enough. We will need to evaluate which material will optimize these failure stresses and strains. Also, the materials we decide to use can also affect the amount of light that gets bounced around inside the enclosure. It will be next to impossible to restrict all light from entering, but if we choose a material (or coating) that will absorb most incident light, our design will provide better functionality for the sensor.

Dynamics will be also need to be utilized in the production process, namely to assess the vibrations of the structure. Since this is potentially going to be a very complicated structure, complete with many beams, the more elementary dynamics analysis may not be enough. System dynamics software, such as Simulink, would greatly facilitate this investigation. Dynamics should also be considered to account for the fact that the sensor is moving. The sensor will make up around half of the weight of the system, which means the center of mass will be significantly changing during a demonstration. We must practically eliminate any possibility that the structure might tip over, so we must make sure we analyze the system dynamics for each position of the sensor.

There are also a few elements of physics that will directly affect the function of our structure, namely momentum, moments of inertia, and friction. The sensor is heavy and will require a lot of force to move at a reasonable speed, which will result in a lot of momentum. We will use this concept to gauge the amount of impulse the sensor will feel if it is pressed up against any kind of hard stop. We need to find the moment of inertia of the demonstration unit with the sensor at each possible point in order to comprehend the risk of it tipping over. Friction will affect the ball bearings, the plate that touches the ball bearings, and the interface between the structure and the table it rests on. However, using a material that would result in a high coefficient of friction between the bottom of the structure and the table will be beneficial, as it will decrease likelihood of the unit sliding on the table.

### **Engineering Design Parameter Analysis**

In order to perfect our design, we needed to conduct a thorough analysis of all the components and systems to ensure they meet all of the engineering specifications. In order to do this we needed to develop a more detailed design in CAD. The Alpha Design was a rough concept, without too much detail in exactly how all the subsystems interacted together. We created a design based off the Alpha Design, but in much more detail. To analyze this design, we used Solidworks Simulation to perform a finite element analysis (FEA). The FEA will provide us with critical data that we will use to validate our design. It will give us the best possible model for our system in which we can analyze before we actually build the prototype. We will compare the results from this analysis with the engineering specifications. There are several steps that we have to take in order to begin the FEA.

## Geometry and Bonding Simplifications

One of the problems that we faced in doing the FEA analysis is failure to mesh our model. Without a proper mesh, the analysis performed will be of no use. The smaller the mesh used in FEA, the more accurate the results. However, as the mesh size decreases, the computing time drastically increases. In order to balance the time required to analyze and the accuracy of the model, we had to make some simplifications to part geometries.

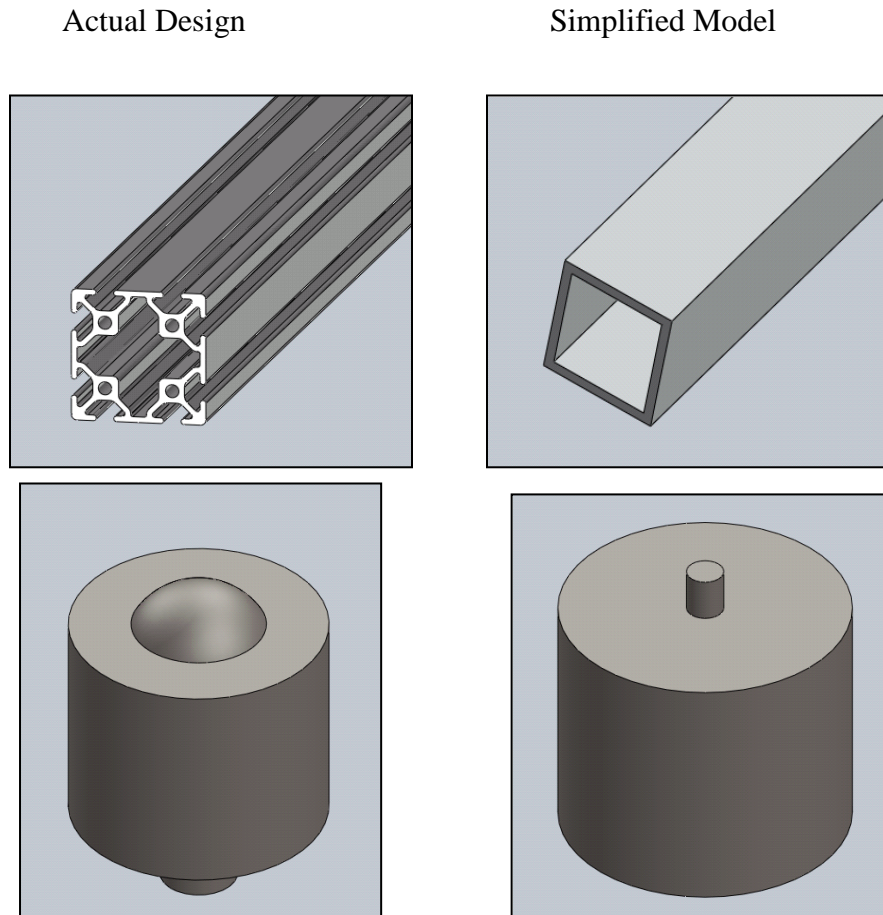
The 80/20 extruded aluminum tubing has a very complicated geometry, as seen in Figure 11 on page 22, and this proves very difficult to accurately mesh. In order to combat this problem, we substituted the complex geometry of the 80/20 with the simple geometry of a square tube. We attempted to keep the mass, outside dimensions, and moment of inertias as close as possible to the original parts. The material for both beams were 6061-T6 aluminum since that is the material the of the 80/20 aluminum tubing. The differences in the values can be seen in Table 9 below.

**Table 9:** Differences in the Moments of Inertia and Mass between the Actual Part and the Simplified Model.

	Actual Part	Simplified Model	Error[%]
Lyy[mm <sup>4</sup> ]	216513	235933	-8.97
Lxx[mm <sup>4</sup> ]	216620	235933	-8.92
Lzz[mm <sup>4</sup> ]	433133	471866	-8.94
mass[g]	997	831.74	16.58

In addition, we also changed the geometry of the ball transfers to allow the model to be constrained and mesh. The Solidworks Simulation would not mesh when the transfer plate was mated to the spherical surface of the ball transfer. In order to get around this problem, we simplified the geometry to be a small cylinder. To simulate the point contact of the ball, the diameter of the cylinder was made as small as we could make it while still able to mesh it.

**Figure 11:** Original Part and the Part Used in FEA



We also simplify the bonding method in our structure. Instead of using bolt, we use ‘Bonded (No Clearance)’ contact option in Solidworks which assume all the parts are welded to each other. This is because bolts and nuts greatly increased the complexity of our structure’s geometry. The angled edges of the bolts proved very difficult to mesh. Also, when making the parts in Solidworks, tapped holes were used, which are undersized for the bolts we would be using. By using the bolt in the holes, it would case an interference which would result in an error.

The mesh information used for all of the FEA analysis can be found in Table 10 on the following page.

**Table 10:** Mesh Information

<b>Mesh type</b>	Solid Mesh
<b>Mesher Used:</b>	Curvature based mesh
<b>Jacobian points</b>	4 Points
<b>Element size</b>	15.18 mm
<b>Total Nodes</b>	67733
<b>Total Elements</b>	34828
<b>Maximum Aspect Ratio</b>	26.952
<b>% of elements with Aspect Ratio &lt; 3</b>	23.6
<b>% of elements with Aspect Ratio &gt; 10</b>	1.12
<b>% of distorted elements(Jacobian)</b>	0

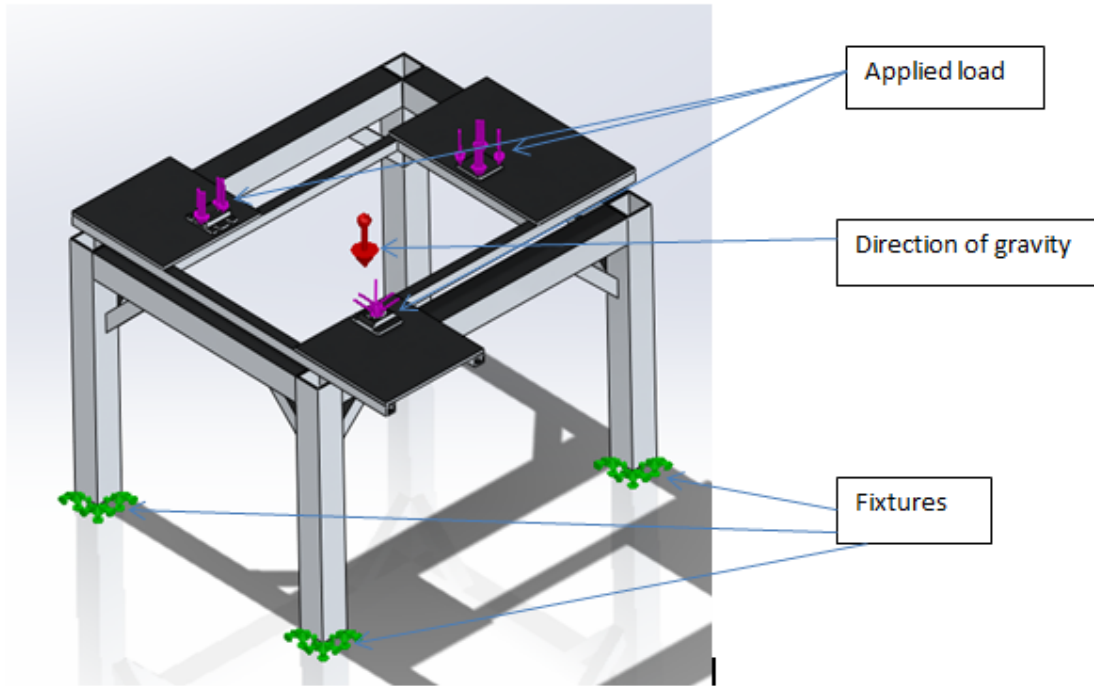
### **Static Analysis**

In this analysis, we are going to determine the maximum vertical displacements of the sensor cause by the deflections of our structure. We also want to know the maximum Von Mises stress in our structure so that we can validate that the structure will not fail under the specified load.

The engineering requirements that we want to validate in this analysis are vertical displacement of the sensor must be less than 5mm and safety factor on strength against yield must be greater than 2. For the safety factor requirement, we will compare the result with yield strength of aluminum 6063-T5 and yield strength of aluminum 6061-T6 which are 150MPa and 260MPa respectively. The yield strengths are given by the material database in Solidworks.

We performed three tests with three different loads, 35lb, 70lb and 140lb. The 35lb represents the weight of the sensor, 70lbs is the weight of sensor with the maximum load that can be applied to the structure, and 140lbs represents a safety factor of two over the maximum load. The loads are applied to the feet that the sensor sits on and contacts the frame. We also fixed the bottom of the legs to the table because during testing the table will be bolted to a steel breadboard metrology table. The setup of this simulation is shown in Figure 12 on page 24. The results are presented in Table 11, also on page 24.

**Figure 12:** Setup for Static Analysis



**Table 11:** Results of Static Analysis

Total Load (lbs)	Max Vertical Deflection of Sensor (mm)	Max Von Misses Stress (MPa)
35	0.16	4.8
70	0.31	12
140	0.61	23

As we can see in Table 11, the deflections of sensor for each load are small compare to the engineering requirement, less than 5mm. The maximum Von Misses stress for each load also are small compare to the yield strength of aluminum specified which are 150MPa and 260Mpa. These results show that our design satisfies the engineering requirements.

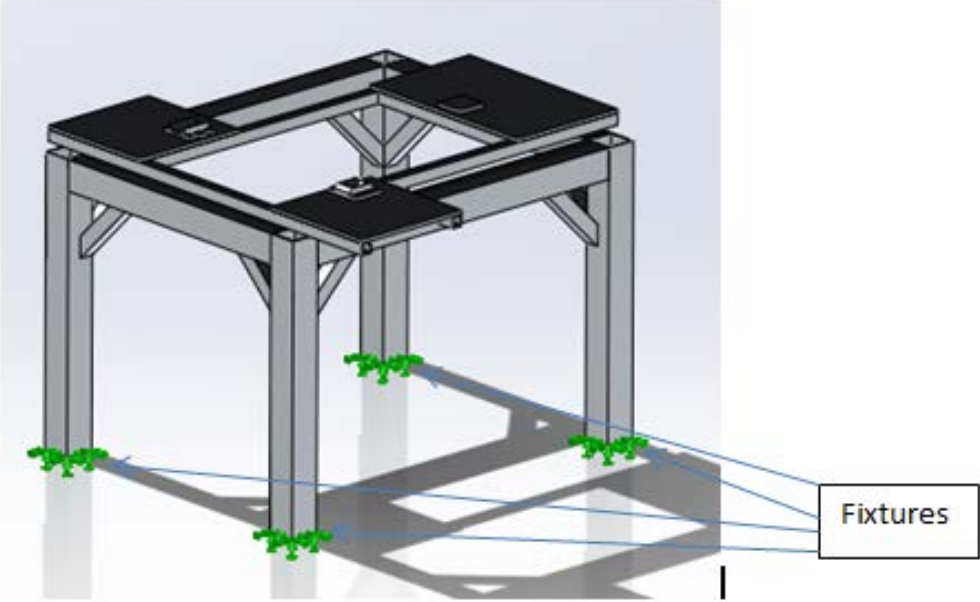
### Frequency Response Analysis

In order to verify that the first natural frequency is above the specified minimum of 30Hz, we performed a frequency response analysis. For this analysis, we use ‘displacement type base excitation’ where we specify the amplitude of vibration of the virtual base where the structure is held fix. We set the amplitude of the base to be 0.05 $\mu$ m because that is the maximum value where the amplitude of vibration of the structure will be less than 0.1 $\mu$ m at higher than 30Hz frequency. We obtained this value from trial and error. We use 80 modes of natural frequencies of our structure in this calculation. This is because Solidworks Simulation requires the mass



participation in this analysis to be more than 80% so that the results will be valid. We also set the frequency range where the analysis will be performed. The range is from 0Hz to 2800Hz. This frequency range must cover all 80 modes of natural frequencies. Other than that, we also set damping ratio to be 5% as stated in Solidworks Help website [11]. We also fixed the leg of the structure like we did for the static analysis. The setup of this simulation is shown in Figure 13, and the details of this analysis are listed in Table 12 below. The results are presented graphically in Figure 14 on the next page.

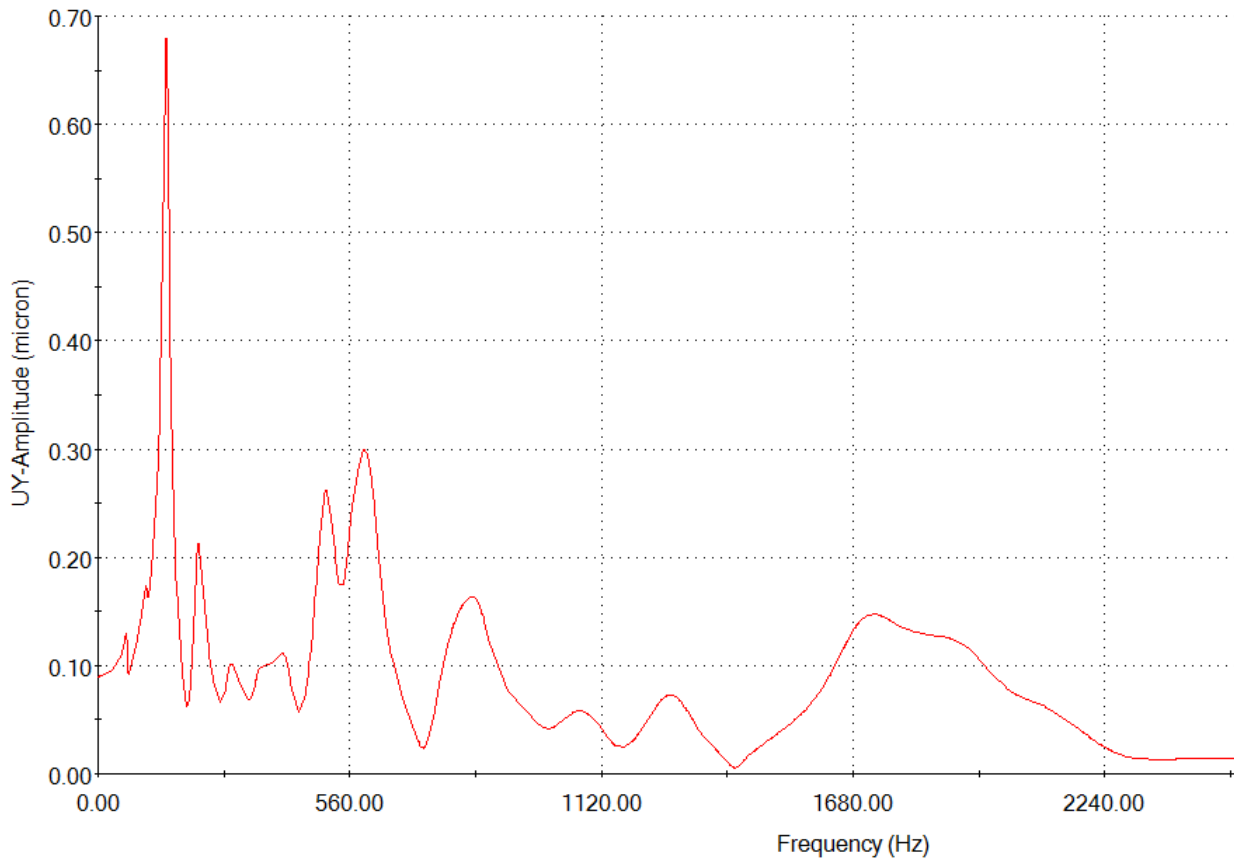
**Figure 13:** Setup for Frequency Response Analysis



**Table 12:** Details of Static Analysis

<b>Number of Natural Frequencies</b>	80
<b>Low Frequency Limit</b>	0Hz
<b>High Frequency Limit</b>	2800Hz

**Figure 14:** Frequency Response of the Structure



From Figure 14, the lowest resonant frequency is 61Hz, which is higher than the engineering specification of 30Hz. The amplitude of vibration of the structure goes beyond 0.1 $\mu$ m at 36Hz if the amplitude of vibration of the metrology table is 0.08 $\mu$ m.

Although the engineering specification that the vibration amplitude be no larger than 0.1 $\mu$ m has been removed, we still wanted to determine what type of base excitation would create this amplitude.

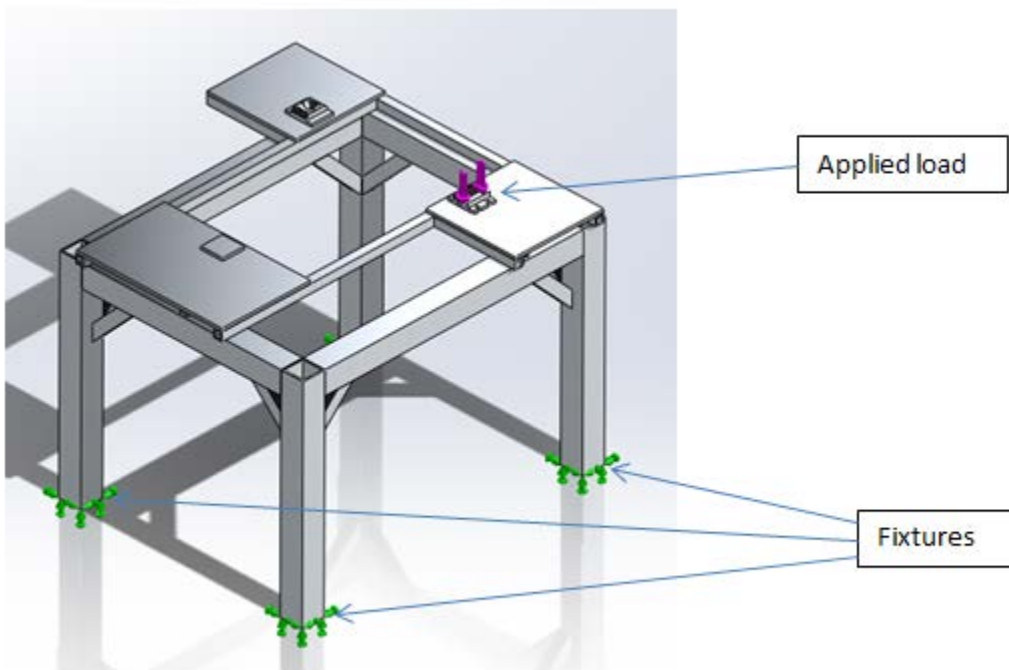
### **Shock Response Analysis**

In this analysis, we are going to determine how the structure reacts to a shock impulse. When the sensor is moving and stops in position, the structure will experience shock. We want to know whether or not our structure exhibit stable or unstable response. If the structure displays a stable response, we want to know the time taken for the structure to return to a steady-state after a shock loading. This time would be the time the operator must wait after the sensor comes to a complete stop to begin running the test.

In this analysis, we have 3 tests with 3 different loads: 5lb, 15lb and 30lb. This is because we want to know whether different loads will affect the response of our structure. The loads will be applied for 0.01 second to simulate shock or impulse input. Other than that, the loads will be applied after a delay of 0.11 seconds so that it will be easier to see results before and after the

loads are applied. We used 80 modes of natural frequencies of our structure in this calculation. This is because Solidworks Simulation requires the mass participation in this analysis to be more than 80% so that the results will be valid. We also set the frequency range where the analysis will be performed. The range is from 0Hz to 2800Hz. This frequency range must cover all 80 modes of natural frequencies. Other than that, we also set damping ratio to be 5% as stated in Solidworks Help website [11]. We also fixed the legs of the structure like we did in the static and frequency analysis. The setup of this simulation is shown in Figure 15 below. The details of this analysis are listed in Table 13. The results are listed in Table 14 on the following page. The response graph for 5lb load, 15lb load and 30lb load will be in Figure 16, Figure 17, and Figure 18 respectively (pages 28-29).

**Figure 15:** Setup for Shock Response Analysis



**Table 13:** Details of Static Analysis

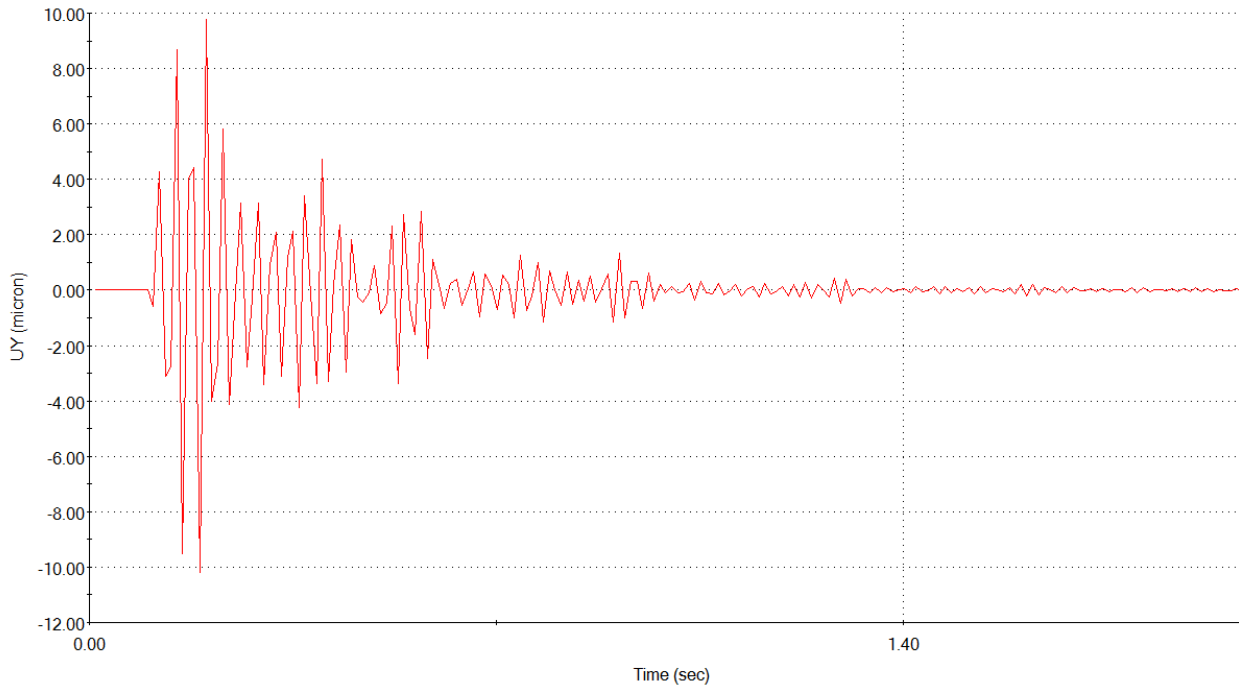
<b>Solver Type</b>	FFEPlus
<b>Incompatible Bonding Options</b>	More Accurate option selected
<b>Number of Natural Frequencies</b>	80
<b>Low Frequency Limit</b>	0Hz
<b>High Frequency Limit</b>	2800Hz
<b>Start Time</b>	0 second
<b>End Time</b>	7 second
<b>Time Increment</b>	0.01 seconds

From Table 13 on the previous page, we can conclude that the shock response of the structure is stable for up to a shock of 30lbs. Because the longest time for the amplitude to reduce to  $0.1\mu\text{m}$  is 3.2 seconds, we can say that this will have a negligible effect on the performance. After moving the sensor, the operator will be required to go to a computer to tell the sensor to take a picture. We believe the time to perform this operation to be more than 3.2 seconds, and if it were not, asking the operator to wait this short period of time would not be unreasonable. This results show that the structure can be used even after experiencing a shock.

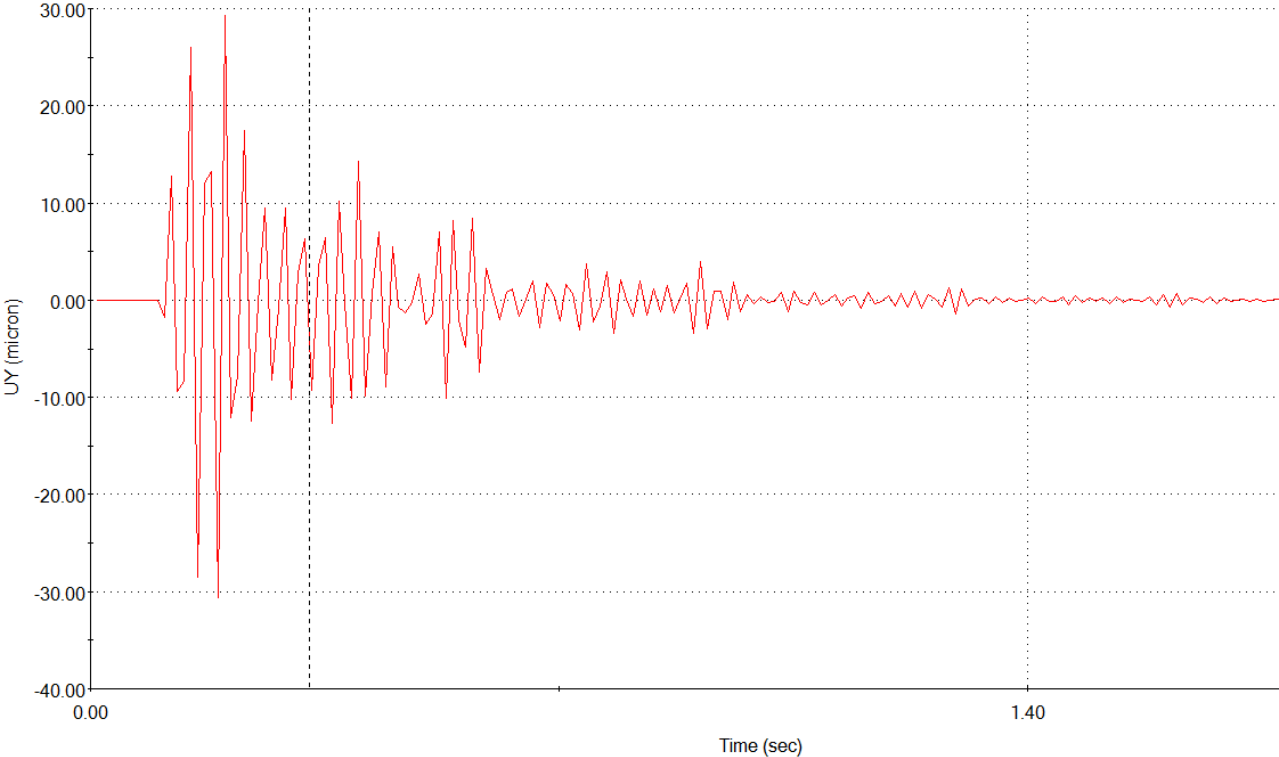
**Table 14:** Results of Shock Response Analysis

Load (lbs)	Response Stability	Time Taken For the Amplitude to Reduce to $0.1\mu\text{m}$
5	Stable	1.8 seconds
15	Stable	2.6 seconds
30	Stable	3.2 seconds

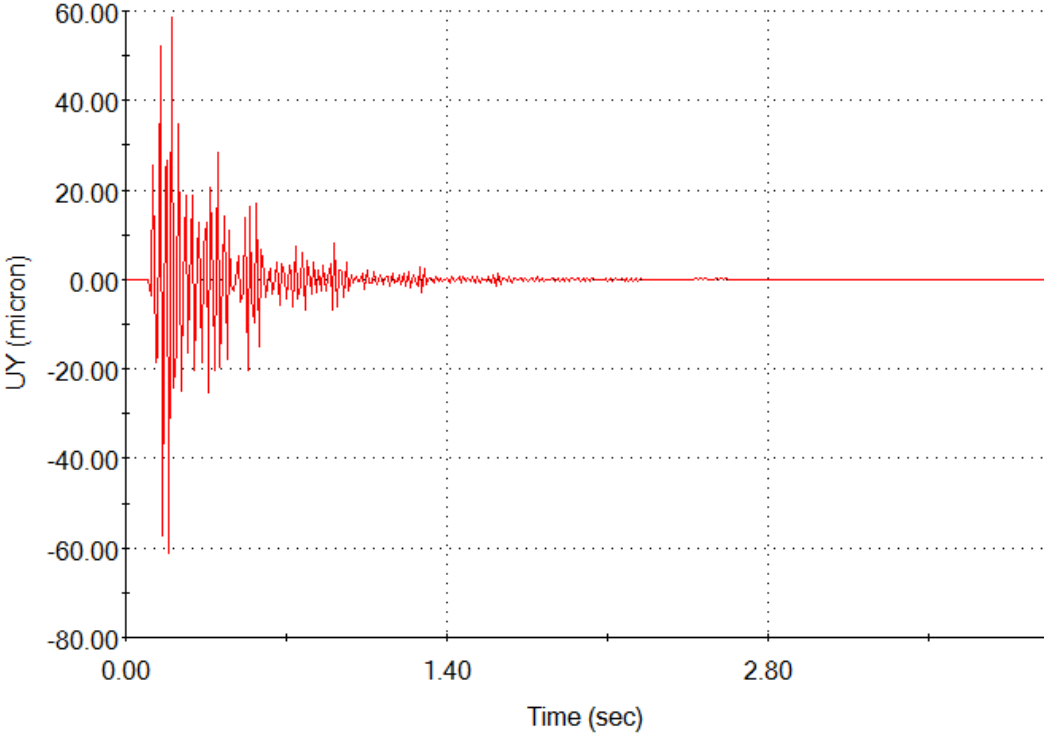
**Figure 16:** Shock Response with 5lb of Load



**Figure 17: Shock Response with 15lb of Load**



**Figure 18: Shock Response with 30lb of Load**



Some of the analysis could have been more accurate had we had more time and experience with the software. If we had no time constraints, we would have added bolts to all of the models, as well as not simplified any of the geometry. This would have drastically increased the computing time, but would have increased the accuracy.

In addition to our finite-element analysis, we conducted a material and manufacturing selection analysis using CES software and SimaPro. This analysis consisted of determining the optimum material and manufacturing processes for the transfer plates and the sensor frame beams. It also was to determine the environmental impact of using the materials needed for a single production unit. The analysis determined that the optimum material for the transfer plates and sensor frame beams were 6013-T6 and 6061-T6, respectively. Unfortunately, we were unable to use either of the two materials due to either budget constraints or availability in the sizes we needed. Instead we used 6061-T6 and 6063-T5 for the transfer plates and sensor frame beams, respectively. We compared the environmental impact of using an aluminum alloy versus using a magnesium alloy. It was determined that the aluminum alloy had a far less environmental impact than that of the magnesium. Next, we determined the ideal manufacturing processes for the transfer plates and sensor frame beams in production quantities. The yearly production quantity for this demonstration unit would be roughly 50 units per year. We did end up using the ideal process for both of the parts, water jet machining and milling for the transfer plates and sensor frame beams, respectively. A full analysis for our material and manufacturing selection analysis, as well as environmental impact study, can be found in Appendix C on page 75.

### **Final Design Description**

After deciding upon our Alpha Design ideas, we further developed and perfected our design. The Alpha Design was a rough concept, and required a more detailed and in depth looks at all the components. The major changes from the Alpha Design to the final design were that the sensor will move atop of three ball transfers instead of four. This will allow the sensor to be statically determinate and prevent the sensor from rocking. The second major design change was the shape of the support structure. Initially, we went with a horseshoe structure over the four legged structure because it would provide better rigidity and a larger contact surface to the table. The larger contact surface would help prevent slippage, as well as distribute the load. We decided to move away from the horseshoe structure because it proved to be too costly. The cost of the 80/20 extruded aluminum was reduced by approximately 30% by eliminating the horseshoe shape. This is a significant cost savings and the engineering analysis showed that four legged structure would be sufficient to meet the vibration and deflection engineering specifications. The final design showing the interaction with the S150 sensor can be seen in Figure 19 on page 32. The demonstration unit that we have designed and will build and deliver to Coherix can be seen in Figure 20 on page 33. The parts are colored to help differentiate between the parts; they will not be this way on the prototype. There are three major subsystems in our final design; the support structure, the sensor frame, and the environmental protection.

The support structure can be seen in Figure 21, also on page 33. It consists of the four legged structure, which is constructed from 50mm by 50mm 80/20 extruded aluminum. The 80/20 extruded aluminum allows the design to have versatility because the support beams will allow parts to be added or moved without needing to drill holes in the structure. This feature makes it valuable to the value added resellers who will be selling this product across the world. The adjustability in the 80/20 will prove useful since four legs are statically indeterminate. If one of

the legs is level with the other three, we can simply adjust that leg down accordingly. The support structure is 693.1mm long, 552mm wide and 473.2mm tall. The 45 degree supports are 160mm long and are fastened together using T-nuts designed to be used in the 80/20 extrusions. The part that will be scanned will be placed inside the support structure through one of the ends.

The ball transfer units in the support structure subassembly and are attached to the support structure at three locations. The ball transfers can also be seen in Figure 23 on page 34. They have a threaded stud on the side opposite to the ball, which is threaded into a plate attached to the support structure. The threaded stud will allow the height of the ball to be adjusted if need be to alter the tilt of the sensor. The ball transfers have balls with a 15.875mm inch diameter and do not have a stated Grade. The manufacturer was unable to provide this information, thus we will assume they are commercial grade, meaning they have a Grade greater than 100, and not precision balls. This was a compromise we made in order to stay under budget. Although the ball transfers will not be as precise, we are confident that they will prove the concept adequately.

The sensor frame of the demonstration unit is comprised of the frame that bears the load of the sensor, the plates that ride on the ball transfers, hard stops to prevent damage to the sensor, and the feet that the mounting balls of the sensor sits atop. The sensor frame can be seen in Figure 22 (also on page 34). The aluminum feet will be provided by Coherix and we will not need to design or build them. One of the feet has a cup, one has a V-groove, and the other is just a flat plate. These three designs will perfectly constrain the sensor. The three feet are attached to the three transfer plates using bolts. The transfer plates are made from 6061-T6 aluminum and are the part that contacts the ball transfers. On the underside of the plates, there are rubber foam bulb seals which act as soft-stops for the ball transfers. When the sensor is about 10mm from being in position, the ball transfer will contact the soft-stop to slow the sensor down. It protects the sensor from potential shock from the ball transfer directly hitting an aluminum beam.

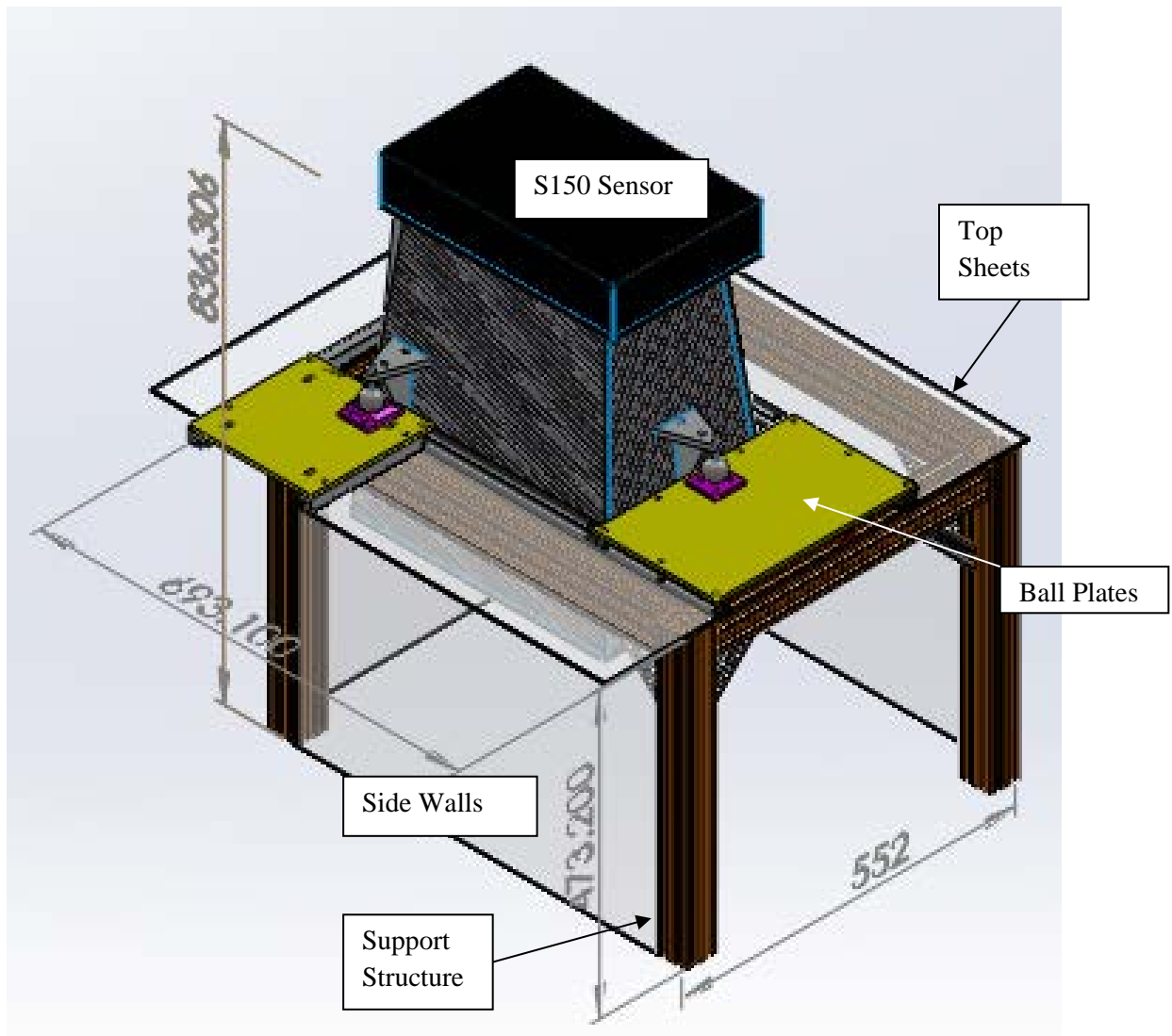
In one of the plates there are four holes to lock the sensor into the four locations. When the plate is rolling atop the ball transfer and it lines up with a hole, the plate will drop down and the ball transfer will go into the hole. This will constrain the location of the sensor, but not the rotation about that point. One of the other plates has grooves that when it mates with the ball transfer will constrain the rotation of the sensor. The third plate will not have any holes or slots, and will just be a flat plate to perfectly constrain the sensor. To compensate for the difference in heights between the two plates with slots and holes and the plate with no holes, we will adjust the height of the ball transfer unit under the plates.

When the sensor is rolling from position to position, the sensor will not be constrained in any direction except downward from gravity, thus the sensor will be able to rotate. Rotation, as well as the sensor potentially going beyond one of locations has the possibility of damaging the sensor. At the rear of the sensor, there is a fragile heat sink that must be protected. To prevent damage to the sensor when it is rotating, we have added in 6061-T6 Aluminum hard-stops to the sensor frame. The hard stops will not contact the frame unless the sensor rotates or goes beyond one of the four locations. The four hard stops, each one located in a corner around the sensor frame, can be seen in Figure 22 on page 35.

The frame portion of the sensor frame is constructed using 6063-T5 Aluminum square tubing. The frame consists of six members and can also be seen in Figure 22. The structural members are held in place using bolts and using the transfer plates as gussets.

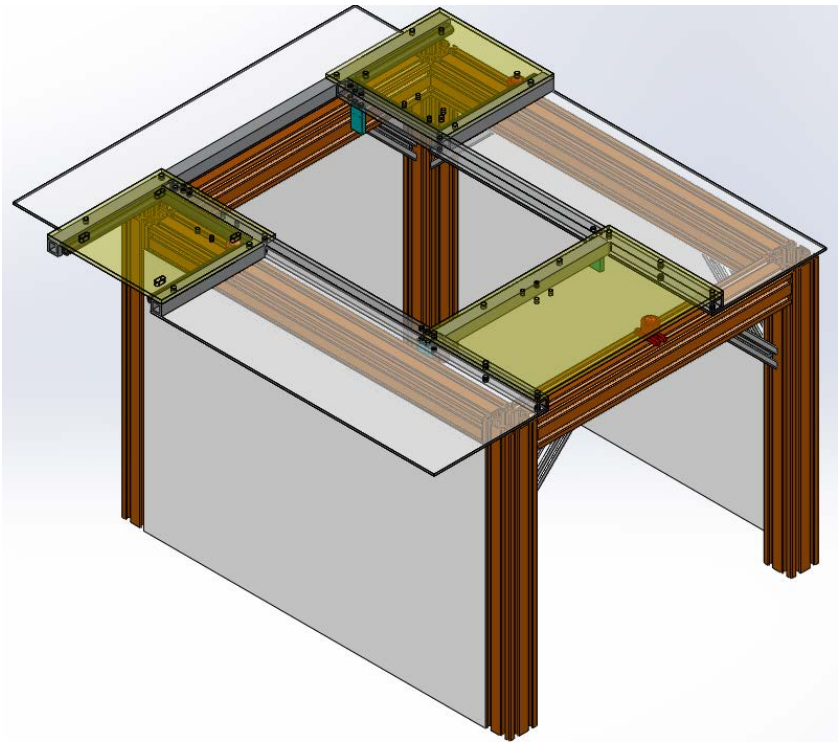
The third subsystem of the demonstration unit is the environmental protection. This subsystem is comprised of six clear acrylic sheets that will aid in keeping the light and wind from disrupting the sensor, as seen in Figure 19 below. The three sidewalls of the acrylic will be clear and their primary use will be keeping out the wind. It is unlikely that the light coming through the clear walls would be able to reflect directly into the aperture of the sensor. The three walls will provide a 'cave like' effect that will make it difficult for the air to flow into it since there is no exit besides the entrance. The top sheets will be painted black in order to prevent light from coming in from the top and reflecting back into the sensor. Another feature of the top sheets is to protect the user from potentially placing their hand in a place that can be pinched. Initially the design to protect against the environment incorporated a door to aid in blocking out light and wind, however, that concept was nixed due to potential safety concerns. The concern was that if you open up the door, it wouldn't be able to open all the way due to the sensor frame getting in the way and the door would fall back and hit the operator.

**Figure 19:** Isometric View of the Final Design of the Demonstration Unit with the S150 Sensor. All of the dimensions are in millimeters

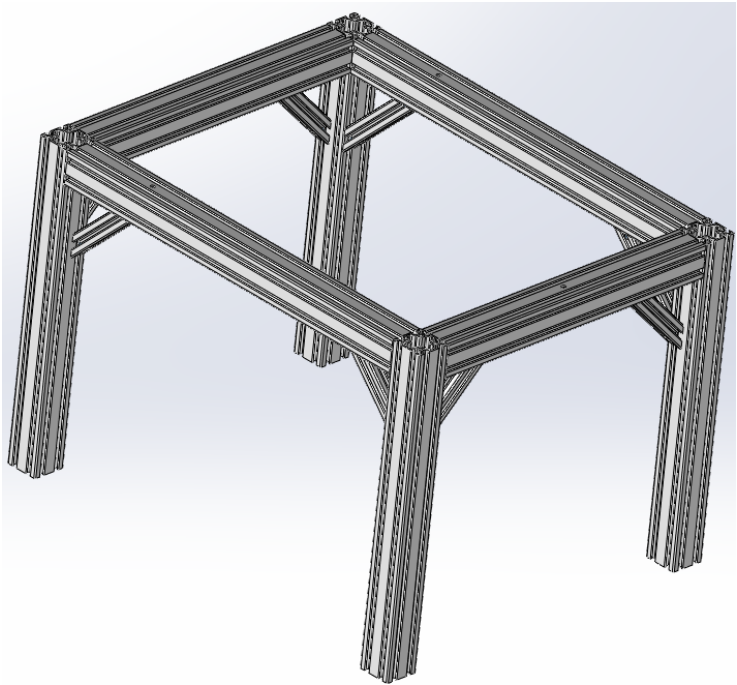




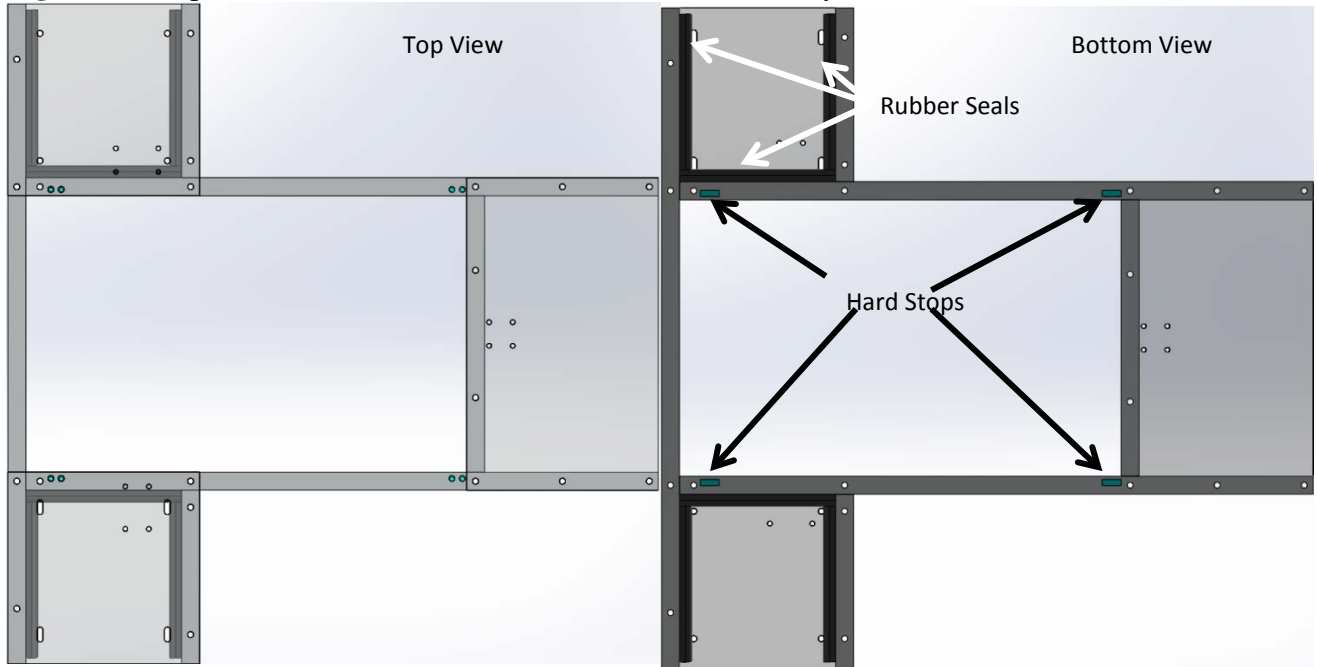
**Figure 20:** Isometric View of Demonstration Unit that we are designing and building



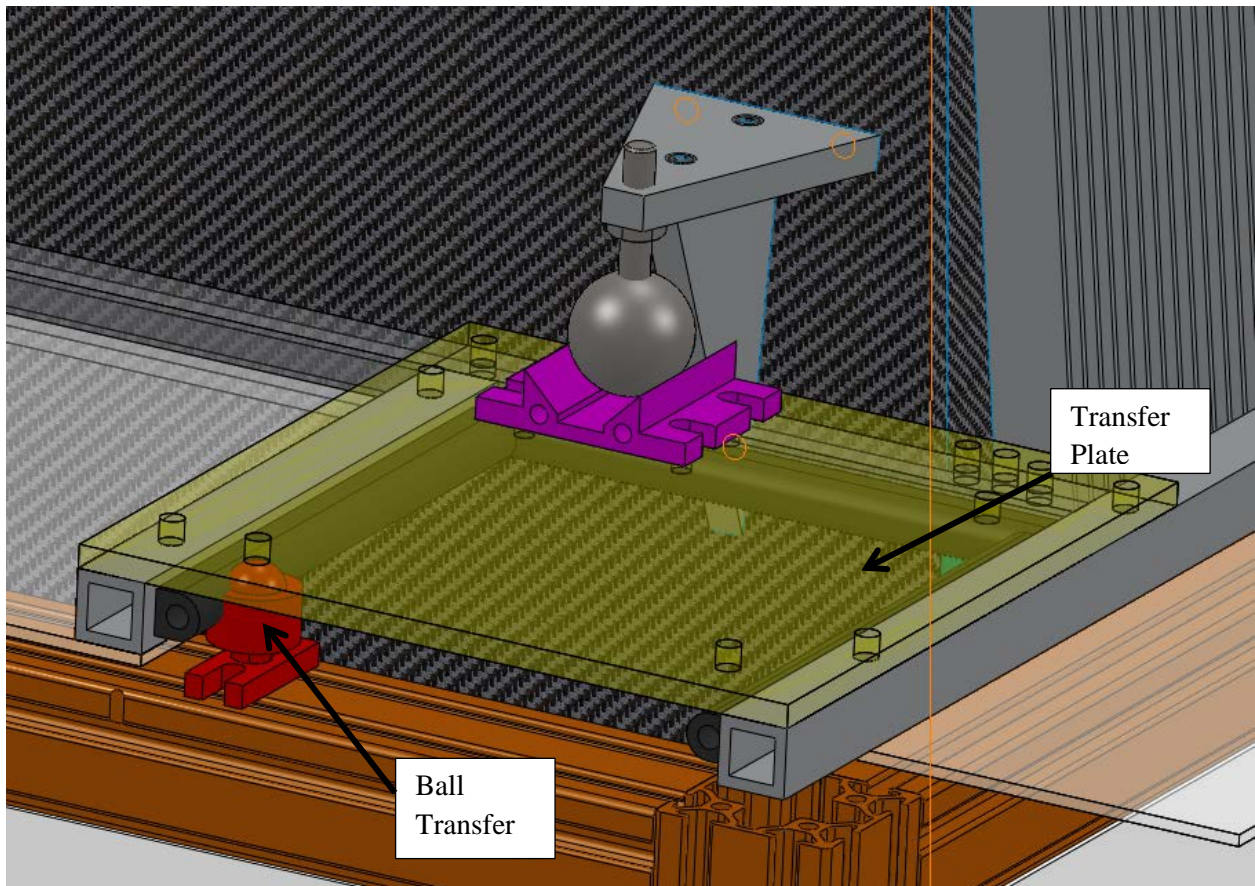
**Figure 21:** Support Structure Subassembly



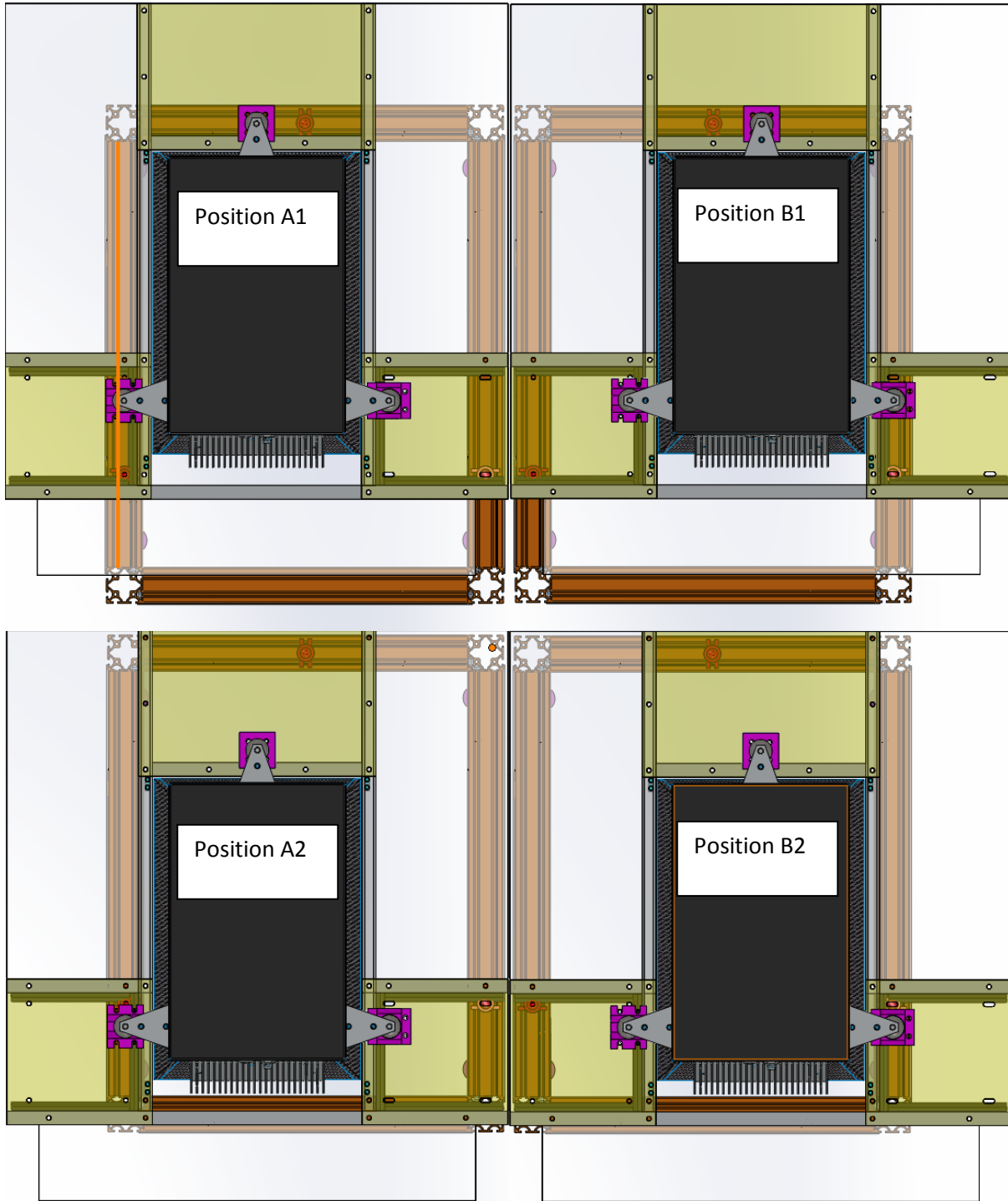
**Figure 22:** Top and Bottom View of Sensor Frame Subassembly



**Figure 23:** Close up of the Ball Transfer and Transfer Plate



**Figure 24:** Top View of S150 Sensor in the Four Locations



**Fabrication Plan**

After settling on the final design, we set forth manufacturing the prototype using the Mechanical Engineering Machine Shop on campus. A full manufacturing plan can be found in Appendix G on page 106. The prototype was machined using several different manufacturing processes. The

transfer plates were cut using a water jet due to the number of holes and cut-outs. The water jet took approximately thirty minutes to set up and cut the three transfer plates, while it would have taken several hours to do it all on a mill. The acrylic sheets were cut using both a laser cutter and a band saw. The band saw was used for rough, non-precision cuts, while the laser cutter was used for making holes and complex cuts. The rest of the parts were primarily manufactured using a manual mill and a band saw. Like on the acrylic, the band saw was used for rough cuts that would later be finished on the mill.

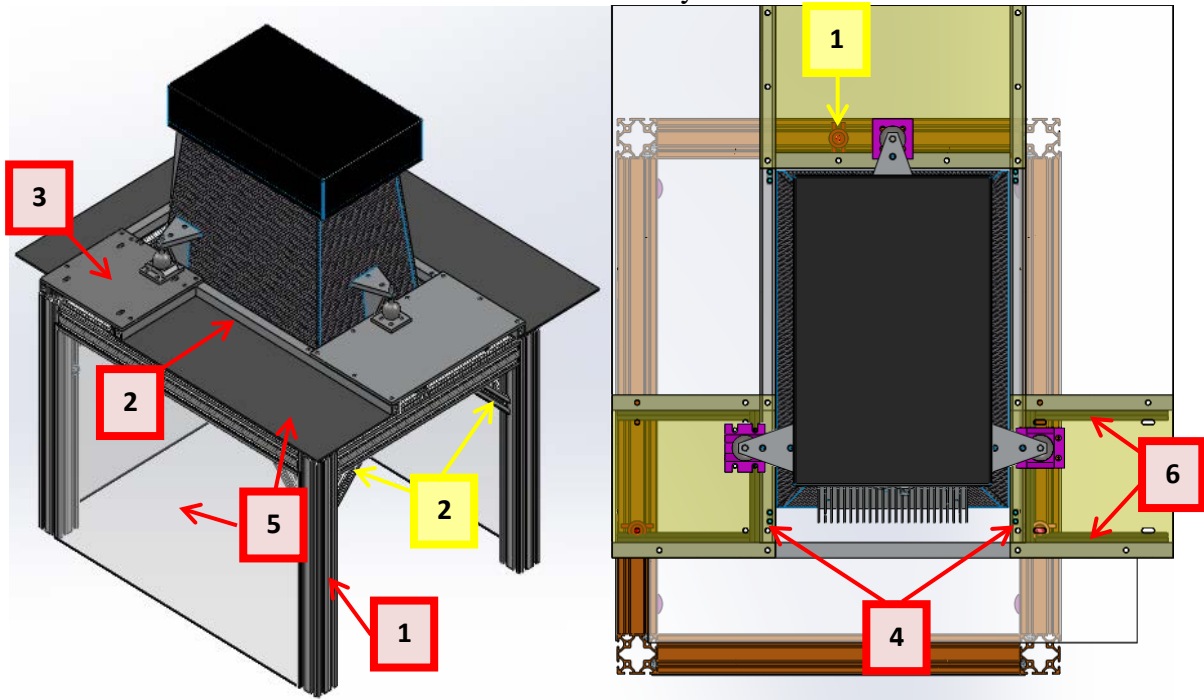
If this design were to go into production, it would be in very low quantities. It would be highly unlikely that more than 50 of these demonstration units would ever be produced. Since it would not be mass produced, it is likely that the cost per unit in raw materials would largely be the same as our prototype. The bill of materials for the prototype can be found in Appendix A on page 63. The manufacturing processes would also largely be the same. The transfer plates would be most easily produced using a water jet and the acrylic would best be manufactured using a laser cutter. The aluminum tube of the sensor frame would likely be still manufactured using a mill. However, the mill would be expected to be a CNC to save machining time. Although using a CNC often costs more due to setting up the code, it will probably be beneficial because of the high hourly rates for a machinist to complete the task.

The assembly process would be done entirely by hand and would not change from the prototype to the production model unless new parts are to be added. With such production quantities, it would be unfeasible to use robotics to assemble each demonstration unit. The step-by-step assembly plan can be found in Appendix H on page 109.

### **Prototype Material and Purchased Component Inventory**

Figure 25 on the next page shows two views of the 3D CAD model of our prototype for the S150 demonstration unit. It will be composed of both purchased components and manufactured materials. The following inventories will show the amount of material needed and the position of each part in the prototype.

**Figure 25:** Isometric and top-down views of prototype CAD model. Manufactured parts are marked with red boxes and purchased components with yellow. Purchased fasteners are not shown for clarity.



Raw Material Inventory for Manufactured Components:

1. T-Slotted Framing

- Material: Aluminum (Alloy 6061-T6)
- Stock Shape and Dimensions: Beam (50mm x 50mm x 7m)
- Source: ThreedSales

Description:

The extruded T-slotted framing will serve as the foundation of our structure. It will be cut and fastened together to resemble a standard four-legged table on which to mount the movement system and S150 sensor.

2. Support Beams

- Material: Aluminum (Alloy 6063-T5)
- Stock Shape and Dimensions: Tube (0.75in. x 0.75in. x 116in., 0.125in. thick)
- Source: Speedy Metals

Description:

The aluminum square tubing will provide a support foundation for the S150 to be placed on to connect the sensor to the movement system.

3. Mounting Plates

- Material: Aluminum (Alloy 6061-T6)
- Stock Shape and Dimensions: Plate (8in. x 36in. x 0.25in.)
- Source: Speedy Metals

Description:

This long aluminum plate will be cut into two 8 inch squares and a 8 inch by 13 inch rectangle to be used as an interface to roll along the ball transfer units to move the sensor.

4. Hard Stops

- Material: Aluminum (Alloy 6061-T6)
- Stock Shape and Dimensions: Plate (8in. x 36in. x 0.25in.)
- Source: McMaster-Carr

Description:

The leftover aluminum plate scrap will be used to make four small rectangular parts to be used as hard stops. These will serve to prevent the sensor from bashing into or rolling off the support structure because of human error.

5. Hard Case

- Material: Acrylic
- Stock Shape and Dimensions: Sheet (18in. x 24in. x 0.09in.)
- Source: Home Depot

Description:

A hard case will be placed on the outside of our structure on all sides but the front, forming a “doghouse” like shape. Each of the sides will be single rectangles that are left transparent, but the top will consist of three separate rectangles, and must be painted black to prevent light. These will serve as protection for the sensor’s field of view from ambient light and wind currents, which can distort the sensor’s images.

6. Handle Bar

- Material: Aluminum (Unknown Alloy)
- Stock Shape and Dimensions: Scrap – Tube (0.75in. x 0.75in. x 32in., 0.0625in. thick)
- Source: Scrap – ME X50 Lab

Description:

The handle bar facilitates the process of moving the sensor and its frame from position to position. We added the handlebar after finishing the prototype upon realizing the amount of effort required to move the system around. We used this material because it was readily available in the assembly room.

Purchased Component Inventory:

1. Ball Transfer Unit

- Quantity: 3
- Vendor: McMaster
- Catalog Listing: 6460K21

Description:

Three ball bearings will be used as the structures source for movement. They will be fastened to the T-slot framing, and the sensor plates will be placed on top so that the rolling balls will translate the sensor.

## 2. T-Slotted 45° Braces

- Quantity: 8
- Vendor: ThreedSales
- Catalog Listing: 25-2565

### Description:

These are necessary to hold the T-slotted framing together. There are other methods to fasten the beams together, but these will provide enough support for our structure without being too expensive or heavy.

## 3. M6 x 35mm Socket Head Screws

- Quantity: 20
- Vendor: Carpenter Bros. Hardware Store
- Catalog Listing: N/A

### Description:

These will be the principal fasteners used in the sensor's support frame.

## 4. ¼"-20 x 0.5" Long Bolts

- Quantity: 12
- Vendor: Carpenter Bros. Hardware Store
- Catalog Listing: N/A

### Description:

These will be used to fasten the conical mount, the V-groove mount, and the flat plate directly in contact with the sensor's three mounting balls.

## 5. Adhesive Backed Foam Rubber Seal

- Amount: 17ft
- Vendor: Carpenter Bros. Hardware Store
- Catalog Listing: 288233

### Description:

This seal will be placed along the sensor's support frame anywhere that may come into contact with the ball transfer units. It will reduce shock on the sensor caused from the frame bashing into metal components.

## **Final Prototype Design**

The prototype very nearly resembles the Alpha Design concept presented earlier (page 18), but we did have to make a few changes throughout the process. The engineering change notices are documented and can be found in Appendix B on page 65. Some of the changes included changing most of the fasteners from metric to imperial units and adding a handlebar to the sensor frame. There were no M6 x 1.0 taps available in the machine shop, therefore we had to change all tapped holes from M6 to ¼-20 because that was the closest size to a M6 available. The final prototype can be seen in Figure 26 below.

**Figure 26:** Final Demonstration Unit Prototype

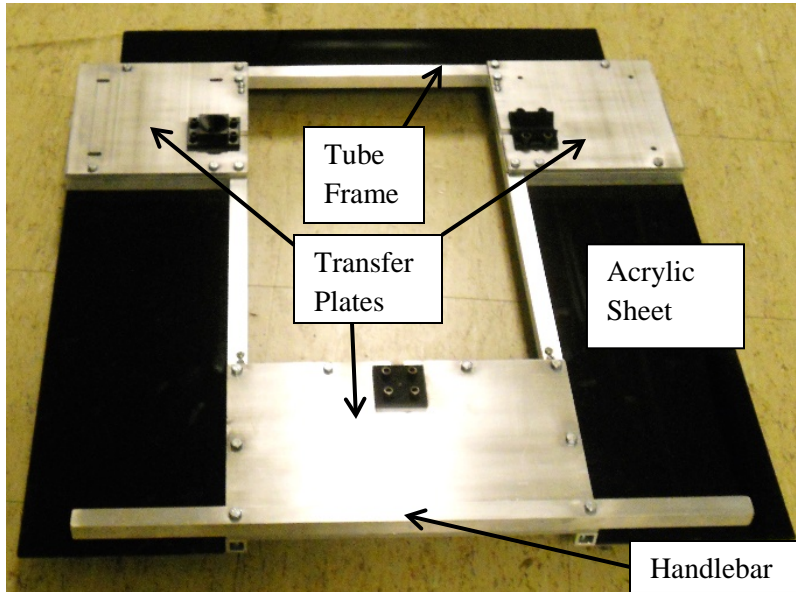


The prototype is comprised of two major sub-assemblies, the sensor frame and support structure. The two sub-assemblies allow the prototype to be easily disassembled for transportation.

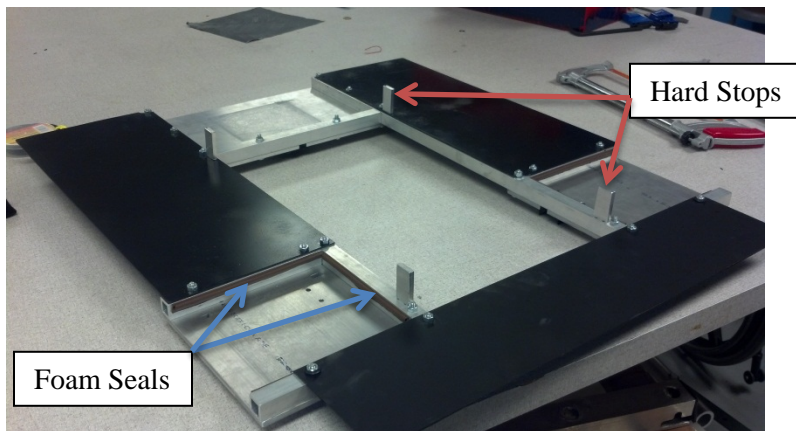
The sensor frame consists of several distinct parts that all serve a different purpose. The frame itself is made of ¾" square aluminum tubing with a 1/8" thick walls. The transfer plates contact the ball transfer units and roll over the support structure. The plates are made of ¼" 6061-T6 aluminum plate. They also act as gussets holding the frame together and lock the position of the sensor in position. The three plastic feet that the mounting balls of the S150 sensor rest on are also attached to the transfer plates. The black acrylic sheets are attached to the frame and prevent ambient light from entering the structure and hindering the performance of the S150. The handlebar was added so that it was easier to position the S150 from the front of the prototype. The last major parts of the sensor frame are the hard stops. They are located on the underside of the sensor frame and prevent the S150 from colliding with the walls of the support structure and also prevent the sensor frame and S150 from simply falling off. The sensor frame can be seen in Figures 27 and 28 on the next page, and the support structure can be seen in Figure 29 on page 42.



**Figure 27:** Sensor Frame Subassembly

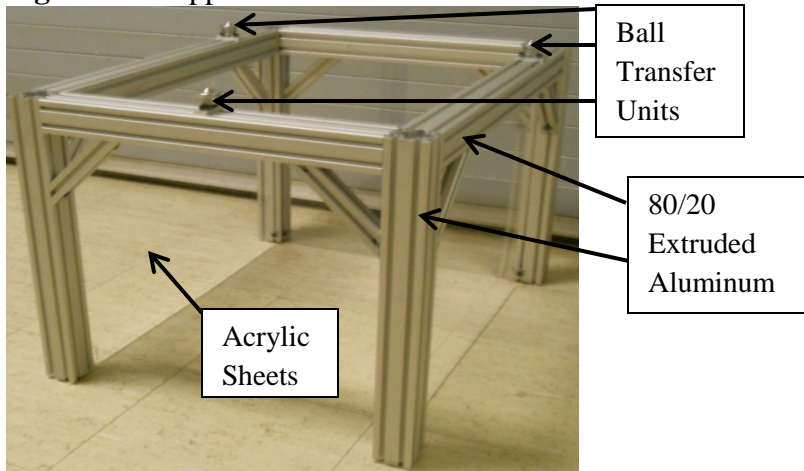


**Figure 28:** Underside of the Sensor Frame



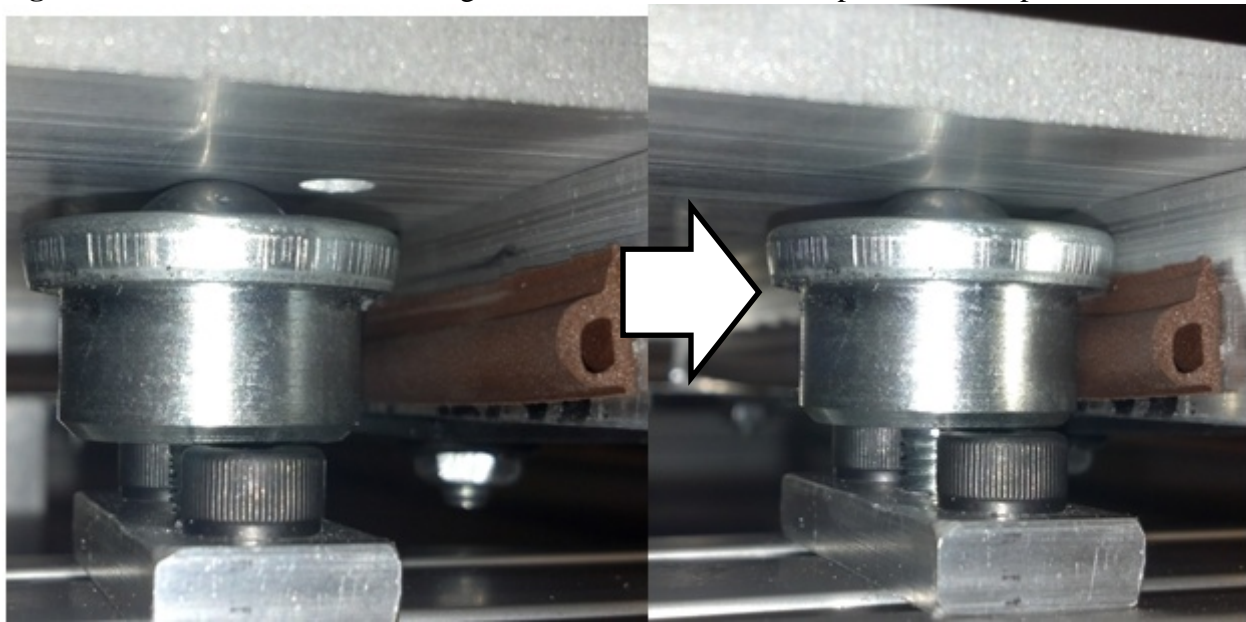
The support structure is used to hold the sensor frame, and is comprised of three main sections. The first is the 80/20 extruded aluminum framework that provides the load bearing structure. The 80/20 is 50mm x 50mm and allows parts to be fixed to it without the need of machining. The second section consists of the ball transfer units which allow the sensor frame to glide atop the support structure. The acrylic walls are the third section and they are responsible for preventing air currents from moving between the sensor and part to be imaged. The support structure can be seen in Figure 29 on the following page.

**Figure 29: Support Structure**

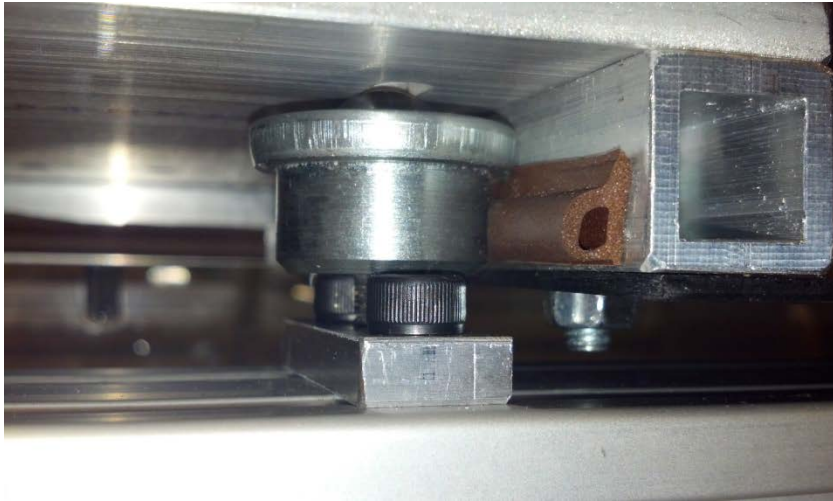


The method of securing the S150 and sensor frame in position relies on four holes in one transfer plate and four slots in the opposite plate. Each hole and slot corresponds to one of the four positions that the S150 can be placed in. When the S150 is moved into location, the ball transfer lines up with the hole and the slot and the sensor frame falls into place. This provides the S150 to be securely fixed without over constraining the system. This system is also automatic and requires no secondary effort to lock it. There is rubber foam weather stripping that the ball transfer units come in contact with just before it is locked in place. The rubber foam prevents the metal to metal contact of the ball transfer unit housing and the sensor frame tubing. It also gives a slight resistance making the ball transfer units stay in position a little better and prevent them from vibrating. Figures 30 and 31 show how the ball transfer units fall into the holes and slots. Those figures also show how the ball transfer unit compresses the rubber foam when it moves into position.

**Figure 30: Ball Transfer Unit falling into the hole in the transfer plate and into position**



**Figure 31:** Ball Transfer Unit constrained in a slot.



Operation of the demonstration is very straight forward and can be done with little to no training. First a part is placed inside the structure, as seen in Figure 32 below. Then the operator grabs the handle bar and moves the S150 into the desired position. The four positions the S150 can be located in are in the four corners of the support structure. Even though there are no guides to make sure the S150 can only go into the four locations, the operator just needs to move it to the corner and it'll automatically be secured in position.

**Figure 32:** Plastic Mock S150 with a part inside the structure



There are six pieces of acrylic on the prototype and they all serve to prevent outside conditions from affecting the performance of the sensor. The three attached to the sensor frame are painted black on the bottom face to prevent light from entering from the top and bouncing back into the face of the sensor. The three sheets attached to the support structure are placed inside the grooves in the extruded aluminum. This gives them a nice appearance, as well as makes them easy to manufacture. They are clear and are primarily used to prevent air currents from moving between the S150 and the part beneath. Although they allow light through, there is little chance of the light from the sides actually reflecting back into the face of the sensor and distorting an image.

There are a few major differences between the prototype and the final product. The biggest difference was the fact that due to cost constraints we could not purchase precision ball transfer units. The drawback of this compromise was that the motion wasn't as smooth as possible and the ball transfers made a rattling noise. Both of these would be unacceptable in a production model of a demonstration unit for a precision 3D holographic sensor. All of the aluminum would also need to be hard-coat anodized black to prevent wear and reduce the amount of light reflecting off the aluminum into the S150 face. Despite the non-precision parts and the bare aluminum, we have confidence our design will meet all of the engineering specifications and prove that this concept is a viable option for Coherix moving forward.

A complete bill of materials for the prototype can be seen in Appendix A on page 63. The bill of materials is broken down into two categories, purchased materials and donated materials. The donated materials are those that we obtained either from Coherix or from the X50 assembly room. These materials were not counted toward our budget of \$400. We spent a total of \$385.13 on materials for this project. Engineering drawings of all components can be found in Appendix F on page 87.

### **Experimental/Validation Plan**

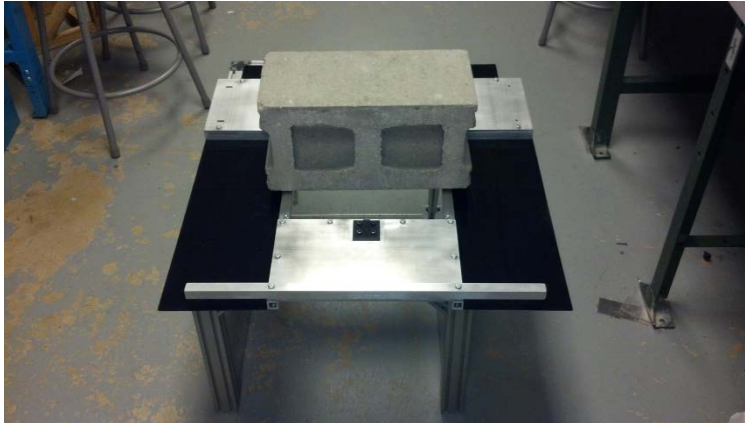
After we manufactured all the parts and assemble the demonstration unit, we will not be able to simply hand it over to the sponsor and tell them that it meets their engineering specifications. Rather, the structure must go through multiple tests to validate our design for each spec. Some tests will be as simple as weighing the structure with a scale or measuring the height of the sensor face from the working surface with a meter stick. Some, on the other hand, will be more difficult and require sophisticated equipment and software.

#### **Test 1: Height of Sensor Face/Deflection of Structure**

The first test was to determine if the sensor's face is at the specified fixed height of 300mm above the working surface within 5mm. The tolerance comes from the sensor's indicated working depth of 5mm. We also have to prevent the structure from deflecting too much, which would cause the height of the sensor face to step out of these bounds. Our goal was to prevent deflections greater than the specified value of 5mm. Since these quantities are large and do not necessarily have to be measured with high precision, we can use a meter stick to measure this height, as long as it measures to the millimeter (which provides a resolution of 0.5mm). To ensure the validity of our structure, this was done at each of the four positions that the sensor will be fixed in. The test was performed on a solid steel table in the ME student machine shop that was measured to be flat within  $0.1^\circ$  with a digital protractor. Because we did not have the actual sensor with us, we approximated the load with a cinder block placed on the center of the sensor

frame, as shown in Figure 33 below. The cinder block weighs 34lb, which is roughly the total weight of the sensor. We measured the maximum deflection to be on the beams at the center of the cinder block.

**Figure 33:** Because we did not have access to the actual sensor, the load is approximated by a similar weighted cinder block placed on the center beams of the sensor frame.



Procedure:

1. Assemble structure on flat table
2. Place acrylic model of sensor in position
3. Place sturdy, flat meter stick on the ground, facing up, against the model
4. Position a straight edge (another ruler) perpendicular to it along the sensor's face
5. Record the measured height at this position, then the other three positions
6. Record the height of sensor's face at this position
7. Replace the model with a block weighing approximately 35lb on the center beams as far toward the back as possible (put masking tape on the beams to protect them from scratches).
8. Move apparatus into one of four fixed positions
9. Record height of sensor's face at this position
10. Repeat steps 3-6 for the three other fixed sensor positions

Results:

The acrylic model turned out to be missing a part that is on the face of the actual S150, so the extra height had to be added to our measured value. Also, the sensor, as well as the model, is mounted using balls with adjustable heights. This obviously gives a range of heights, so we used the point where the sensor was as low as possible to be our reference. At this reference point the height of the sensor face above the working surface was measured to be 297.5mm, which falls within the specified range of 295-305mm. Though it is on the low end of the specified range, note that the S150 has an adjustable height via the ball mounts, and 297.4mm is the *lowest* the sensor face can be. Next, we determined whether or not applying a load would take this height out of range. Using a cinder block as an approximation to the sensor, we determined that at each position, the deflection of the supports were no more than 1mm. Additionally, since the structure must have a safety factor of two, we added a second cinder block directly on top of the first one, and determined the deflections of the horizontal beams. With a total load of 69lb, the maximum

deflection at any position of the sensor was found to be less than 2mm (actual value is just over 1.5mm, but taking into account the resolution of the ruler at worst case scenario). This test has shown that even at double the sensor's weight, the height of the sensor will deflect much less than the maximum specified value of 5mm in the Z-direction.

## **Test 2: Structure Weight**

The second test will prove that the weight of our structure is less than the specified limit of 35 pounds, which is the limit that many union workers may carry without any restrictions. The shape of the structure, however, will make it difficult to fit on a scale, so we took a flat board and placed it on the flat scale first. Then we put the structure on the board and weigh the combination and subtract the weight of the board to determine the weight of the structure itself. This was done in the G.G. Brown Mechatronics Lab, on a scale which measures up to 0.01lb, with a limit of 150 pounds

Procedure:

1. Place calibrated weights (approximately 30 pounds) on a flat floor scale
2. Calibrate the scale accordingly
3. Place flat board (3' x 3' or larger) on scale and record its weight
4. Place full structure (without the sensor) onto the board and record the combined weight

Results:

The scale was precisely calibrated to the hundredth of a pound. Using the methods outlined above, we determined that the weight of the bottom support structure was  $23.36 \pm 0.05\text{lb}$ , and the top sensor frame was  $12.25 \pm 0.05\text{lb}$ , which came to a combined weight of  $35.64 \pm 0.1\text{lb}$ . This total weight is 0.64lb higher than the specified maximum weight of the structure. However, our structure is designed to be moved in two smaller parts, so no one will have to lift more than 24 pounds at a time. Because of this, no one will be in danger of lifting anywhere near 35 pounds when using our structure, which is the reason for this weight limit. Thus, we can conclude that the specification has been met.

## **Test 3: Natural Frequency**

We will then need to determine whether or not the structure meets the vibration specifications. We need to make sure the structure's natural frequency is greater than 30Hz to reduce the risk of resonance vibrations in the structure. This threshold was chosen because of the typical metrology table that will be used with the structure will dissipate external frequencies higher than 30Hz, so the higher the natural frequency, the lower the risk of reaching resonant frequencies. In order to analyze the vibrations of the finished prototype, we attached a fine accelerometer to the sensor itself, which had a data acquisition system attached to connect to a computer, where a program will convert the electrical signals into actual vibration data. The particular accelerometer-acquisition system that we will use for our testing is the same setup that Coherix uses for similar tests on other devices, so the test will be done at their facility. The surface used is a four foot square passive isolation steel breadboard table; the accelerometer is a multi-axis Model601A02 accelerometer and will be connected to a Model 480C02 signal conditioner and an 8 bit National Instruments Data Acquisition Card. Vibrations were induced in two ways: dropping a heavy sandbag on the table the structure is standing on, and by striking the table with a rubber mallet.

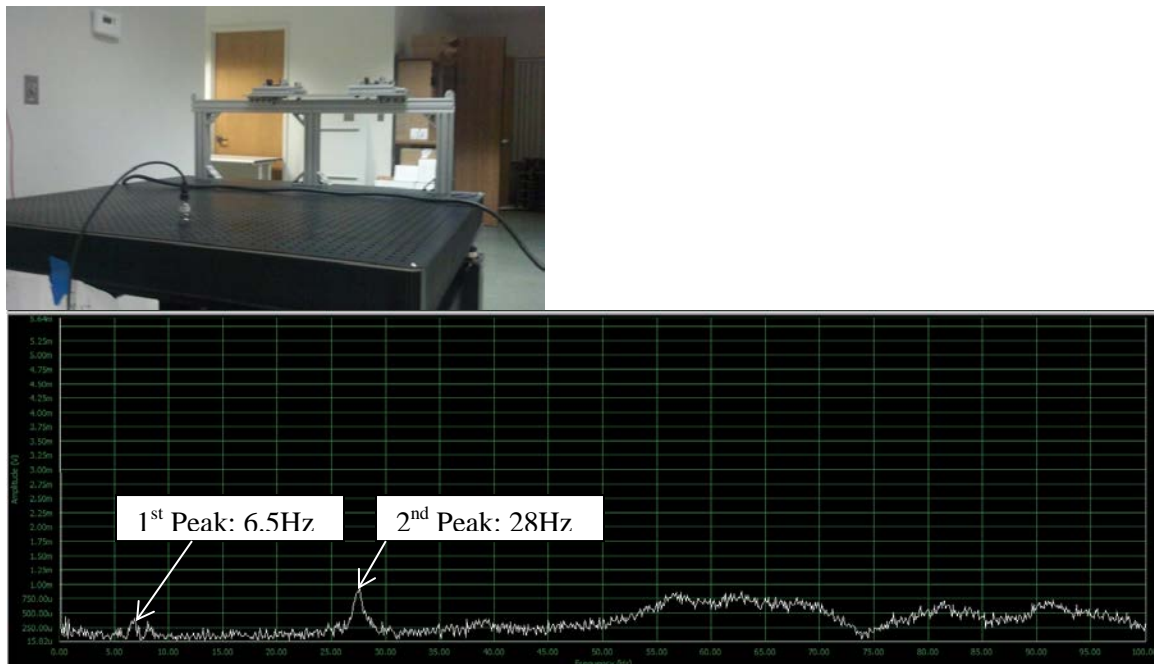
## Procedure:

1. Strike the table without anything on it to determine the natural frequency of the testing apparatus. This frequency should be *carefully* disregarded during future tests (the structure may have the same natural frequency)
2. Place demonstration unit with sensor onto the four foot square steel breadboard table
3. Mount accelerometer to one of the ball transfer plates, as close as possible to the sensor feet
4. Move the sensor to one of the four fixed positions
5. Hit the table as close to the center as possible with a rubber mallet, hard enough to get a good response from the accelerometer, but not too hard. If the system is hit too hard, it will “saturate,” which causes the data to be incorrect. If saturation occurs, discard the data and try again.
6. Repeat step 5 a few more times to ensure an accurate response
7. Try this at all four fixed positions and all three ball transfer plates to make sure the natural frequency is good at all

## Results:

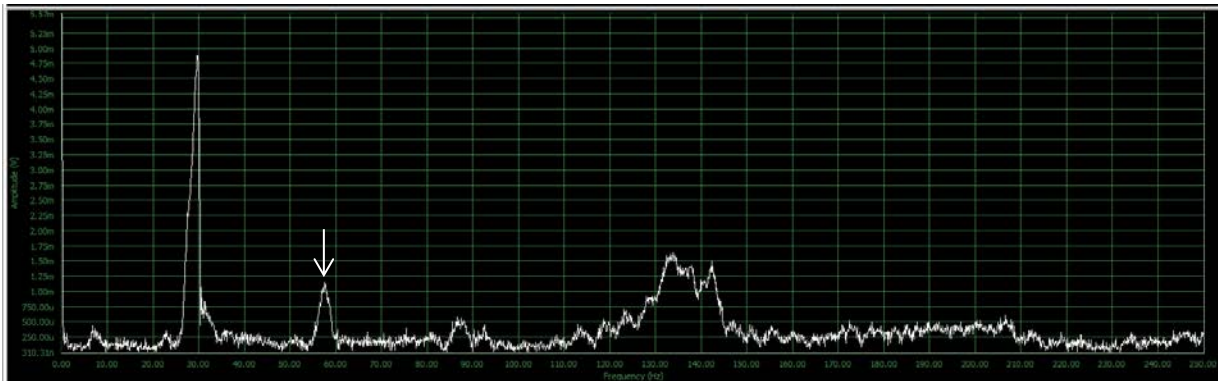
Our first few trials were determining the natural frequency of the testing apparatus by striking the table with a rubber mallet at a reasonable force. We found that the table itself had associated with it natural frequencies of about 6.5Hz and 28 Hz. The actual test setup and frequency-amplitude distribution for this test can be seen in Figure 34 below. This test was repeated a few times to ensure accurate values.

**Figure 34:** The resulting frequency distribution chart of the testing table without the structure on it. This shows that the first natural frequencies of the testing apparatus are 6.5Hz and 28Hz. Table also has a structure made out of T-slotted aluminum attached to it, which is the source of the second natural frequency.



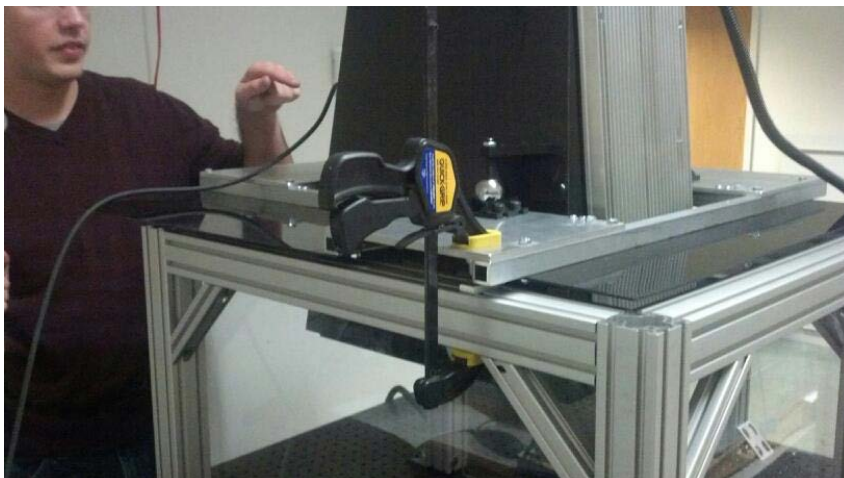
Next, we placed our structure on the table and the S150 in the sensor frame and repeated the test. The resulting natural frequency distribution was recorded with the same range, and can be seen in Figure 35 below. Note that the amplitude for the 28Hz peak is much larger in this test than that of the previous. This is due to an error in the impulse input into the system. However, this result is still given because it gives the lowest natural frequency possible in our structure. Other tests to prove this follow below.

**Figure 35:** The hammer test repeated with our prototype on the table and the S150 in position. The first peak beyond the 6.5Hz and 28Hz of the table itself is the lowest natural frequency of our structure, which is 57Hz as marked by the arrow.



Initially, we measured a smaller range of frequencies for determining the table's response, so we missed the second peak of 28 Hz. This caused us to think that this peak was due to our structure, which would put us under the minimum value of natural frequency required for the system. We tried many different adjustments to our structure to increase the stiffness and damping to bring this number up, including clamping the sensor frame down, taping the acrylic to the sensor frame, and taping the ball transfer units. These modifications are outlined in Figures 36 below and Figure 37 on the next page.

**Figure 36:** We initially believed the main source of vibration in the system was the interface between the sensor frame and the support structure. To combat this, we determined that clamping the plates directly to the support structure would greatly increase the stiffness. However, due to our small range in recorded frequencies, we still measured the same peak at 28Hz.





**Figure 37:** We then noticed that there were a lot of large oscillations in the acrylic sheets on the top of the structure, so we proceeded by using electrical tape to connect the unstable ends of the acrylic to the sturdy sensor frame. There was an obvious increase in the plastic's stiffness, but the frequency response still showed the peak at 28Hz. At this time we still believed this peak to be our structure's natural frequency.



We continued to make small adjustments, including taping the ball transfer units down to reduce their internal vibrations, but continued to get the same results. Finally we unbolted our prototype from the table and tried testing the table by itself again (this time with a higher range of frequencies plotted). The same 28Hz peak was recorded yet again with only the table. Thus, we concluded that the peak we have been obtaining in the previous tests were all part of the table.

We continued by placing our structure back on the table to continue testing with an even higher frequency range (up to 100Hz). A few final tests with the rubber mallet showed that the lowest natural frequency occurs at 57Hz, which is higher than the specified minimum by 27Hz. Though it seems that the previous tests were unproductive, they provide evidence that our structure does not affect the natural frequency of the table in any way (which would be the case if the prototype had the exact same resonance at 28Hz). Since increasing the stiffness at just about every major part of our system did not change the position or size of that peak, we concluded that it was indeed not the structure. In conclusion, the prototype passes the minimum specified natural frequency required.

#### Test 4: Tilt

The next test determines whether or not the change in the tilt of the sensor does not exceed  $0.2^\circ$  in either direction between each of the four fixed locations, per the specification. The S150 has a built-in tilt testing program, which makes this test very simple and accurate. The sensor is able to check the absolute angle measurement in both the X and Y-directions to a thousandth of a degree. This must be done at all four positions of the sensor, and then the smallest measured angle was subtracted from the largest in each direction to give the largest change in tilt. This was also done on the 4' x 4' steel breadboard table at Coherix's facility.

Procedure:

1. Place demonstration unit on steel breadboard table and bolt it down, then set the S150 in place
2. Run tilt-measuring program of sensor at each of the four fixed positions
3. Make a table of each recorded tilt in each direction
4. Subtract the smallest X-angle from the largest X-angle, and the same for Y-angles, to get the maximum change in tilt for both directions

Results:

The resulting table of tilts, as measured from the S150 sensor at each of the four fixed locations can be seen in Table 15 below.

**Table 15:** The tilt measurements in both the X and Y-directions given by the S150 at each given location. The maxima and minima are bolded for clarity.

Axis	Position	Tilt
X	A1	0.043°
	A2	<b>0.037°</b>
	B1	0.038°
	B2	<b>0.048°</b>
Y	A1	-0.015°
	A2	-0.052°
	B1	<b>-0.063°</b>
	B2	<b>-0.012°</b>

A1	B1
A2	B2

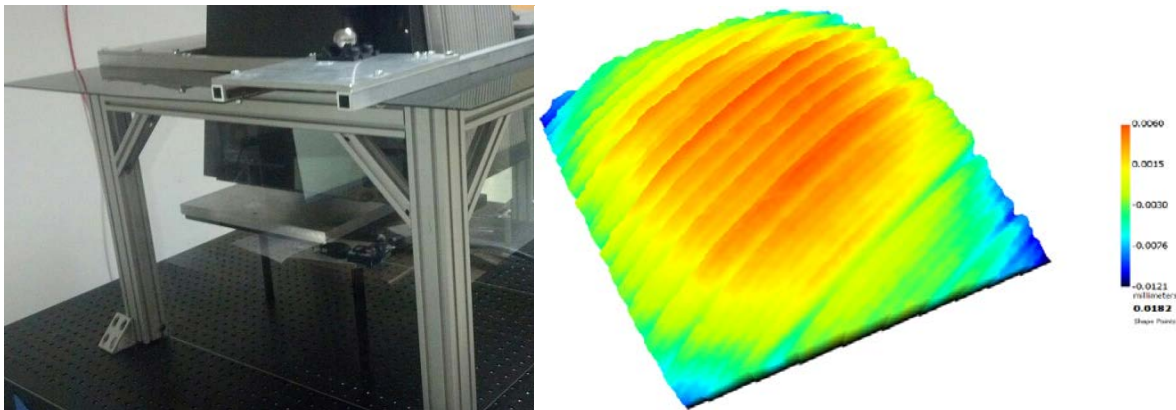
We found that the greatest difference in tilt is  $0.051^\circ$  about the Y-axis and  $0.011^\circ$  about the X-axis. This shows that our design meets the engineering specification that the maximum tilt cannot exceed  $0.2^\circ$  in any direction. In fact, the structure provides a tilt of 25% of the maximum allowable in the Y-direction, and 6% of the maximum tilt in the X-direction. However, due to the large amount of time that this test takes, we were only able to measure the tilt once. To ensure

that this data is consistent, it is recommended that this test should be repeated at least twice more, reassembling the structure between each consecutive trial.

### Test 5: Protection from Environment

The final test proves whether or not our design prevents ambient light and air flow from distorting the images taken from the S150 sensor. Unfortunately, there is no way to quantify how much of environmental factors are too much for the sensor, as it differs depending on the situation. The best we can do is empirically take sample images from the sensor on an actual object. We did this on the same four foot square steel breadboard table as the vibration and tilt tests at Coherix's facility, and the sample object was a precision-ground flat aluminum plate seen in Figure 38 below. Four images were taken of the plate (one at each of the fixed position). The figure also shows a resulting image of the plate shown with the sensor's 0.1 $\mu$ m resolution. Each of the images taken is similar to this, not showing any signs of obstruction due to environmental sources. For this reason, we concluded that our structure adequately protects the field of view of the S150 from ambient light and wind, and thus pass this specification. This has been confirmed by Coherix.

**Figure 38:** The S150 mounted in the prototype demonstration unit, with a flat aluminum plate underneath. Also shown is the resulting image, which is not distorted by ambient light or air currents.



### Test 6: Footprint of Structure

The maximum amount of the table that the bottom of our structure takes up (i.e. the footprint) must be less than 914mm x 914mm. In order to prove that our structure's footprint is within this specification, two simple measurements need to be taken: the distances between the outside corner of one of the structure's legs to the outsides of the two adjacent legs. This will form a rectangle with the maximum possible footprint of our structure. The device used to make this measurement is a large set of calipers from the ME machine shop in G.G. Brown, measuring up to three feet.

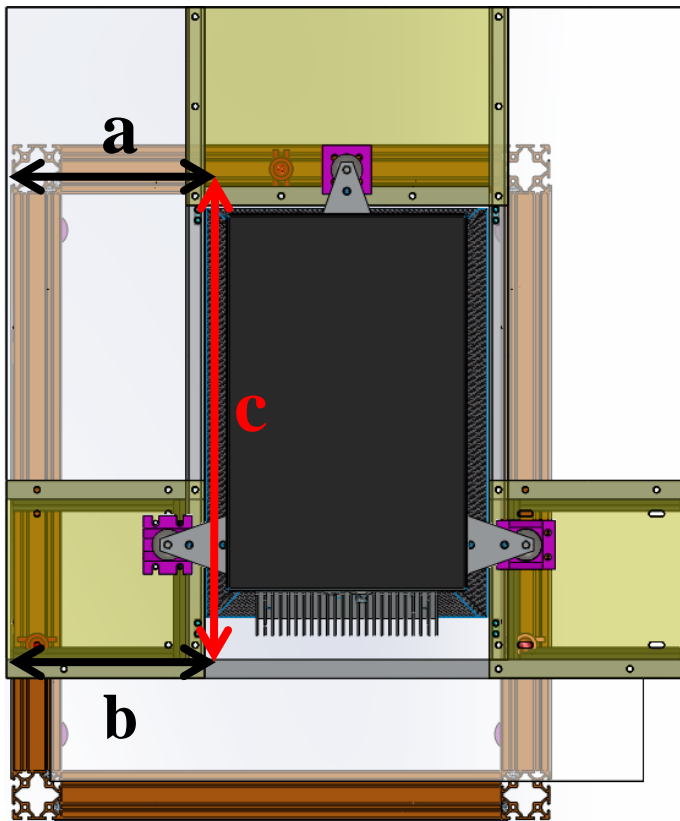
Results:

We found that the footprint of our structure was 552.0mm x 692.1mm, falling well within the specified upper bounds of 914mm x 914mm.

### Test 7: Accuracy in Z-Axis Rotation of Sensor

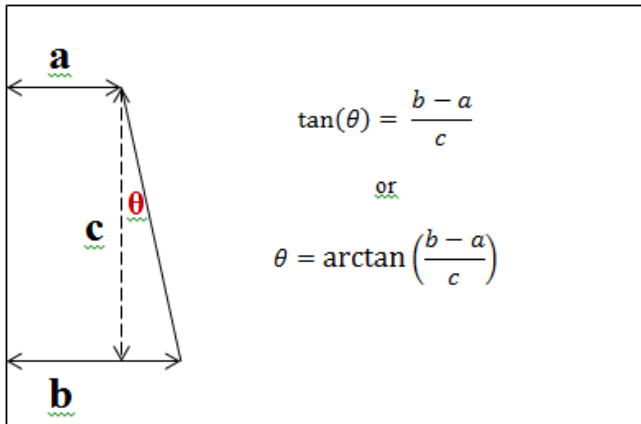
In addition to reducing the change in tilt in the X and Y-directions (parallel to table), our structure must also restrict change in rotation along the Z-axis (normal to table). The sensor must not rotate in this direction more than  $\pm 0.5^\circ$  at any of the four fixed positions, per the specification. This is to prevent any sizeable error in the process of stitching the four images together. In order to accurately determine the rotation angles of the sensor, a series of careful length measurements must be taken, and then trigonometry must be used to translate the lengths into angles. To ensure precise dimensions, a set of 10" calipers were used for all length measurements. Figure 39 below shows exactly which lengths were taken into account.

**Figure 39:** The reference edge (datum) was taken to be the outer edge of one of the longer beams of the support structure. Length “a” was measured to be the distance between the datum and the inside corner of the front ball transfer plate. Length “b” is the distance between the datum and the back inside corner of the sensor frame. Length “c” is the distance between the two previous measurements.



These measurements were taken from the same datum at each of the four fixed positions of the sensor. Length **b** was always slightly longer than **a**, so the resulting measurements yielded a schematic such as the example in Figure 40 below. The tilt angle  $\theta$  can be calculated from the measurements using the trigonometry to the right of the figure.

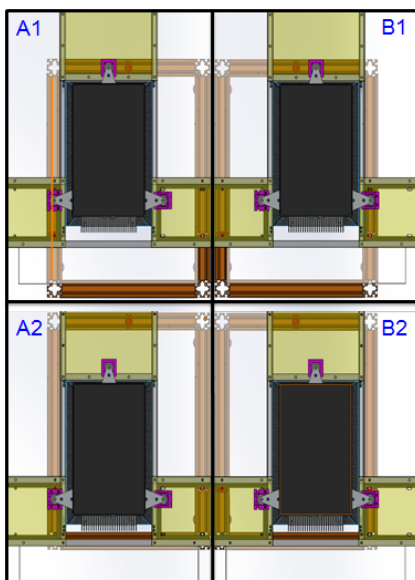
**Figure 40:** A sample schematic of the measurements, showing the relationship between the lengths measured (from above) and the tilt angle of the structure.



Results:

The previous measurements and calculations were done at each of the four fixed sensor locations, as labeled in Figure 41 below. The resulting measurements and tilt angles are arranged in Table 16 on the following page. Note that length **c** is the same throughout, with a constant value of 26.39in.

**Figure 41:** The four fixed locations of the sensor.



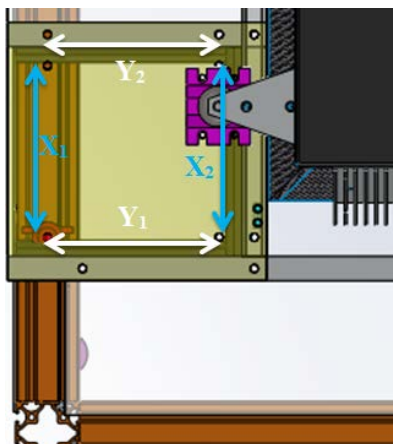
**Table 16:** Recorded measurements of lengths **a** and **b**, as defined above, and the calculated rotation angle about the Z-axis. Clockwise rotation is considered to be positive. The results show that the maximum amount of rotation between positions is 0.332°, which is within the allowable range of  $\pm 0.5^\circ$ .

<b>Position</b>	<b>a (in.)</b>	<b>b (in.)</b>	<b><math>\theta</math> (deg)</b>
A1	2.316	2.420	- 0.226
B1	7.589	7.839	- <b>0.543</b>
A2	3.351	2.448	- <b>0.211</b>
B2	7.589	7.828	- 0.519

### Test 8: Accuracy in X-Y direction of Sensor

The final test we performed was to prove that when the S150 is in any given fixed location, its position is within  $\pm 1\text{mm}$  of where it is supposed to be. In other words, as it moves from position A1 to B1, and B1 to B2, it should move the required 135 mm, with a tolerance of 1mm. This is also to prevent errors in stitching the images together, as the rotation test was. To collect this data, a set of calipers was used to measure the distances between each pair of adjacent holes (or grooves) of the ball transfer plates. For clarity, this is represented visually in Figure 42. This measurement is an accurate representation of the location of the sensor because the holes were manufactured precisely, and the ball transfer units will constrain the sensor by landing directly in the centers of these holes. To accurately measure the distances between the center of two holes, two lengths must be taken by the calipers: the distance between the closest points of the holes and the distance between the longest points of the holes. The center distance can be calculated as the average of these two values.

**Figure 42:** Four measurements are done for both of the back plates: the distance between each of the adjacent holes. The blue arrows represent the distances measured for the accuracy in the X-direction, while the white arrows represent that of the Y-direction. These distances must be between 134mm and 136mm in order to pass this specification.



## Results:

The measured distances can be seen for both of the back ball transfer plates in Tables 17 and 18 below. The maximum deviation from the expected 135mm distance was -0.1mm, which is well within the specified tolerance of  $\pm 1$ mm.

**Table 17:** Measurements of the four dimensions from Figure 42 above measured on the transfer plate with the holes, along with the amount of deviation from the measured to the expected value of 135mm for each.

Dimension	Length (mm)	Deviation (mm)
X1	134.95	0.05
X2	134.90	0.10
Y1	134.93	0.07
Y2	134.98	0.02

**Table 18:** Measurements of the four dimensions from Figure 42 above measured on the ball transfer plate with the four grooves, along with the amount of deviation from the measured to the expected value of 135mm for each.

Dimension	Length (mm)	Deviation (mm)
X1	134.90	0.10
X2	134.92	0.08
Y1	134.92	0.08
Y2	134.94	0.06

## Design Critique

The greatest strength of our prototype is the fact that we used an innovative, yet very simple design to meet the specifications. Our task was to design a demonstration unit that utilized an original, yet simple design that would achieve all of the engineering specifications. Although our prototype met all of the engineering specifications, there are still several ways we could improve on our design.

If we could redesign our prototype, we would think more about the operator-device interface. Since the demonstration unit is manually operated, a closer look is needed at how the S150 is moved from location to location. We only added the handlebar to the sensor frame after manufacturing the prototype and realized it was difficult to move from position to position. We should have seen this as a potential problem and had we done so, we could have designed it to be much more ergonomic and more visually appealing. At the Design Expo, we had several people attempt to use our demonstration and it proved to be difficult for most. Even with instruction on how to correctly position the sensor, most people still struggled to put it in the correct location. Some form of guides to prevent the operator from rotating the sensor would have helped a great deal. Grooves in the plates that would direct the sensor from position to position would be a

simple way to remedy this issue. We would recommend that thicker transfer plates be used if grooves were used in order to prevent the rigidity of the plates from being compromised.

We had several issues with the ball transfer units we used in the prototype. The ball transfer units we used were non-precision grade rather than precision grade because the precision grade balls were too expensive for our budget. The ball transfer units we used did not roll as smoothly as hoped and made a rattling sound while rolling. Both of these would be unacceptable to a customer who is investing \$100,000 in the S150 sensor. While we can almost guarantee that had we used precision ball transfer units, the motion would be smoother. Some companies sell ball transfer units with Nylon or Acetal balls that would certainly be quieter, but may or may not be as smooth.

The stud-mount ball transfer units were selected so that we could adjust the height of each of them individually to change the tilt of the sensor. When we assembled our prototype, we realized that the stud-mount ball transfer units wobbled when in motion, especially when the S150, or equivalent weight, was added to the structure. In order to combat this, ball transfer units had to be tightened as much as possible. This eliminated the possibility that we could then adjust the height of them. If we used flange mounted ball transfer units instead of the stud-mounted, it would have made the system more rigid and more robust.

### **Recommendations**

Based on the design critique above, there are several recommendations that should be heeded if Coherix decides to move forward with this design.

The first recommendation would be to utilize precision grade ball transfers and an aluminum plate for the transfer plates that has a material certification that meets ASTM B221 standards. Although the transfer plates we used did not have this material certification and still met the specifications, it could become an issue at some point. Therefore, in order to ensure that all the demonstration units are of the highest quality, we would recommend using precision ball transfer units and aluminum plates with a material certification. The only retailer we could find that would sell precision ball transfer units in low quantities was Omnitrack.

Due to time and budget constraints, we were unable to anodize any of the aluminum on our prototype; however, we would highly recommend this be done on any production models. The anodizing would give the prototype a more uniform appearance and hide scratches in the aluminum. If stainless steel ball transfer units are used, the aluminum transfer plates should be hard-coat anodizing to increase their wear resistance.

We also recommend that the ball transfer units not be of the stud-mount variety. The benefit of potentially being able to adjust the height is outweighed by the fact that they are less rigid and precise adjustments are difficult. We would recommend the use of a flange-mount where the base is secured by four screws. The use of plastic ball transfers may reduce the rattling sound and improve the smoothness of the motion. Plastic balls would reveal new wear issues if the same hole and slot locking mechanism is used. This could be avoided if the aluminum transfer plates did not have the locking mechanism, but instead had a hard plastic plate attached beneath it with the holes and slots. This would keep the rigidity of the aluminum plate, but would reduce the wear on the balls since they would be rolling on plastic. Additionally, grooves could be added to



the plastic plate to help guide the sensor from position to position without the risk of compromising the rigidity of the structure.

## **Conclusion**

Coherix has asked us to design and build a demonstration unit for their new S150 sensor. This demonstration unit will allow them to reach a new market of smaller businesses in the automotive industry. In order to accomplish this project, there are many strict requirements for the structure. It must be able to demonstrate the full functionality of the sensor and allow potential customers to see the versatility of the structure. The engineering specifications listed in Table 1, page 8, detail the tight tolerances we will have to work with to make the project a success. We weighted the customer requirements with these engineering specifications and created a quality function deployment which ranked the importance of the specifications. We determined the deflection of the horizontal support beams, meaning the rigidity of the structure, was the most important spec using the QFD. Without a rigid structure, we will not be able to produce a system that produces high quality images. We performed a literature review to search for patents relating to X-Y linear motion tables. We concluded that a basic X-Y table patent is no longer active, but most tables involving actuators are have active patents, which means they may be available commercially. We developed a plan to achieve all of our goals and provide a successful product. The timeline is provided in Figure 25 on page 50 and it shows that we are using the design reviews as our major milestones. It gives enough cushion for the most critical tasks that if we run into challenges, we will be able to go to a backup plan. We anticipate that we will into issues trying to stay in tolerance for the vibration frequency and amplitude, as well as the rotation and tilt of the sensor. Purchasing precision components can be expensive and time consuming. In order to combat this, we will need to be disciplined and stick to the plan.

We performed a functional decomposition of the structure and determined six major tasks that our structure must accomplish. It must hold the sensor up 300mm off the table surface, it must be able to move between the vertices of a 135mm square and be fixed in these positions. The structure must also protect the enclosed area from ambient light and air flows, as well as prevent tilt in the structure. We had a brainstorming session to determine any ideas that could possibly accomplish these tasks. This complete list can be seen in Appendix B on page 56. We performed feasibility and go/no go analyses to eliminate the unreasonable or outrageous ideas. The concepts that passed these tests were then evaluated using Pugh charts, which weighed each design against each other for all the important design criteria. Another brainstorming session commenced to think of any combinations of these ideas that could work better than the concepts alone. With this, we were able to come up with four final alpha design prospects. Again, these were weighed against each other for a comprehensive list of the projects design criteria. The design that scored highest the final Pugh chart was determined to be our Alpha Design. Our Alpha Design consists of a ball transfer movement system atop a horseshoe-shaped structure. We will use a hard case on all sides with a door on one side to minimize ambient light and air flows. The sensor will be fixed into the specified positions using pins (although this idea will be revisited soon). This will also serve as a way to tell if the sensor is in the correct location. There are, however, potential problems that could come up in the design. For instance, three ball bearings must be used on the movement system to make the interface fully constrained, but the weight distribution on each ball will be relatively high. It would be better for rigidity and safety factor purposes to have 4 or

more bearings, but the over-constrained condition will cause potential wobbling of the top plate with the sensor on it.

We built upon the Alpha Design to create a more detailed CAD model using the same principles. Using this more detailed model, we were able to perform engineering analysis to determine if our design would meet all of the customer requirements. We performed three major tests using finite element analysis, a static analysis, frequency response analysis, and a shock load analysis. The static allowed us to determine that our design would meet the requirement that the sensor cannot deflect more than 5mm and not yield within a safety factor of two. The frequency and shock load analysis allowed us to verify that the natural frequency of the structure is greater than 61Hz. The shock load test told us that the amplitude of vibrations will reduce to less than 0.1 $\mu$ m in less than 3.2 seconds given a shock load of up to 30lbs. The engineering analysis gives us confidence that our design will meet all of the engineering specifications.

In conjunction with the engineering analysis, we perfected our design to create a final design that we believe will best suit the needs of Coherix and will meet all the engineering specifications. The design is different than the Alpha Design because we went with three ball transfers instead of four and went with a four legged structure instead of the horseshoe structure. The former was done to make the sensor statically determinate, while the latter was done to reduce cost. The final design can be seen in Figures 19-24 on pages 38-41. Our first iteration of the final design turned out to be at least \$100 over budget. To reduce this cost, we sacrificed the precision on some of the parts, such as the transfer plate and ball transfers, in order to get under budget. The bill of materials can be seen in Appendix A on page 63. With the effort to not exceed the budget, we also needed to rethink the outcome of the project. Originally, the plan was to deliver Coherix a prototype that would work as the production model. However, with the cutbacks from the cost reductions, some parts will only be a proof of concept and not the final production model.

After finalizing the final design, we manufactured the prototype demonstration using the University of Michigan's machine shop. The fabrication process involved us using a water jet to cut the transfer plates due to their complexity. The acrylic sheets were cut primarily using a laser cutter. The rest of the parts were predominantly machined using a manual mill. Access to metric taps was the largest issue in the fabrication process. Unfortunately, the mechanical engineering machine shop did not have an M6-1.0 tap. Therefore, we had to change all of the parts that needed tapped to Imperial units.

The final prototype largely resembled the final design concept. It involved two major sub-assemblies, the sensor frame and the support structure. The two-part design allowed the demonstration unit to be quickly broken down to make it easier on the operator to move. With the S150 on the demonstration, the motion wasn't as smooth as hoped. The method of securing the S150 worked very well, although at times it is difficult to unsecure the sensor from a position. The largest changes involved the adding a handle bar to make the demonstration unit more user friendly. The acrylic walls were moved and placed inside the T-slot aluminum tubing for a better appearance.

After the prototype was fabricated, we moved ahead with the validation testing. The validation testing would determine whether or not our prototype would meet all of the engineering specifications. The two major specifications were the natural frequency of the structure and the tilt of the sensor. Both of these could affect the performance of the S150 if we did not satisfy

them. Through our testing, we concluded that the lowest natural frequency in the Z-direction of our prototype was 57Hz. This met the requirement that it be greater than 30Hz. The frequency test was conducted by placing the S150 in the demonstration unit while the system rested on a metrology table and then striking the table with a rubber mallet. The frequencies were then measured using an accelerometer in different locations on the structure. The tilt test was conducted using the S150 to take an image of a flat aluminum plate in each of the four locations and then measuring the difference in tilt between them. We determined the maximum tilt to be  $0.051^\circ$ , nearly a quarter of the maximum allowable of  $0.2^\circ$ . In addition to these two specifications, we also met all of the other engineering specifications. The full description of the tests and results can be found in the Experimental/Validation Plan section on page 44.

Although our prototype met all of the specifications, there are still several areas to improve on. We would recommend that a future production model feature precision ball transfer units and certified flat aluminum transfer plates. Those changes would ensure that all of the production models be of the highest quality. Furthermore, we would recommend anodizing the aluminum transfer plates with a hard-coat in order to increase wear resistance against the stainless-steel ball transfer units. Additionally, we would recommend using precision plastic balls in the ball transfer units to decrease the noise caused by the metal on metal contact of the current prototype. We were notified that this noise would deter potential customers from using it with a \$100,000 S150 sensor.

Despite the areas that need improvement, the prototype met all of the engineering specifications. It also clearly shows that the concept of using three ball transfer units to precisely position an S150 sensor in four fixed location would be feasible. If our recommendations are heeded, not only would this design meet the specifications, we believe it would be a very successful product to demonstrate the capabilities of Coherix's S150 to new potential customers.

### **Acknowledgements**

Our team would like to express our deep gratitude for all those who helped us throughout the duration of this project.

Our section instructor, Professor Gordon Krauss, provided for us great leadership, direction, and insight, without which we could not have been successful.

We would also like to thank our sponsor Coherix for providing us the opportunity to work on this project. Michael Mater and Daryl Barnich of Coherix both gave us invaluable advice and assistance throughout the project.

We would also like to extend our thanks to Bob Coury and Mark Stock for giving us guidance in the machine shop. In addition, we would like to thank Toby Donajkowski for this assistance in the mechatronics lab.

Last, but not least, we would like to thank all of our fellow students in our section. They gave us vital constructive criticism throughout the design process that we used to ensure our project would be a success.

## **Literature Review**

We performed a literature review consisting of a patent search to determine possible paths we could take to tackle this project. We contemplated how these inventions correlate with our project and whether they are usable or not.

One invention is the “Double Rail Linear Motion Guide Assembly” [3]. The patent number is 5,244,283 and its inventor is Kunihiro Morita. This patent is a double rail linear motion system. It is composed of an auxiliary guide rail and a slider that carries a load. This invention has several variations in the shape of the slider and guide rails, and also how the slider can be mounted onto the guide rail. The date of patent is September 14, 1993, and it expired on September, 2010. It is already expired and we can use some of the technology of the invention in our project.

Another invention is “Precision Scanning Apparatus and Method with Fixed and Movable Guide Members” [4]. The patent number is 6,363,809 and its inventors are W. Thomas Novak, Zahirudeen Premji, Uday G. Nayak, Akimitsu Ebihara. This invention is a platform that can move in ‘X’, ‘Y’ and ‘Z’ direction with precision on top of magnetic rails. It is propelled by linear electromagnetic motors. The date of the patent is April 2, 2002 and it will expire on April, 2022. The patent is still valid, which means we need the permission from the inventors before we implement the technology of the invention in our project.

A third invention is “XY Table” [5]. The patent number is 3,495,519 and its inventors are A. Alfsen and Thomas P. Bluit. This invention is a platform that can move in ‘x’ and ‘y’ direction. The platform is support by 4 rods. By using bearings, the platform can slide on top of the rods in ‘x’ and ‘y’ direction. The platform is move manually by using ball screws. The date of the patent is February 17, 1970 and it expired on February 1987. The patent is already expired and we can use the technologies described in the patent.

A fourth invention is the “X-Y Movement Mechanism” [6]. The patent number is 5,341,700 and its inventors are Richard J. Speranza and Richard A. Speranza. This invention is a mechanism that has a fixed base plate and a movable plate. The movable plate can move in the ‘X’ and ‘Y’ directions. It is moved using a ball screw. The date of the patent is August 30, 1994 and it expired on August 2011. The patent is already expired and we can use the technologies described in the patent.

Another invention is the “Accelerometer Based Tilt Sensor and Method for Using Same” [7]. The patent number is 7,231,825 B2 and its inventor is Lincoln Davidson. This invention is a tilt sensor that is built from three accelerometers. The accelerometers are placed on a common plane with different angles relative to each other. The date of the patent is June 19, 2007 and it will expire on June, 2027. We can buy the accelerometer that can measure the tilt angle from the market.

Finally, there is the “Ball Transfer Unit and Ball Table”[8]. The patent number is 7,370,746 B2 and its inventors are Kaoru Iguchi and Masakazu Takahashi. This invention is a ball transfer unit and a table where it is mounted. The ball transfer unit has housing, a small ball bearing, and a large ball that roll on top of the small ball bearing in the housing. The ball transfer units are

attached to a table to create a ball table. The date of the patent is May 13, 2008 and it will expire on May, 2028. We can buy the ball transfer unit from the market.

Other than reviewing patents, we also read other articles that can help us to succeed in this project.

The first article is about structural vibration. The title is “Structural Vibration: Analysis and Damping” by C. F. Beards [9]. This article discusses the cause of vibration on a structure and analysis on the vibration. It discuss in details about damping system and how to use it to reduce the vibration. This article also presents the mathematical models for each type of vibrations. This article will really help us to understand more about vibration properties of our structure and how we can use dampening to reduce the vibration amplitude.

The second article is about validation of Autodesk Simulation software accuracy. The title is “Autodesk Simulation Accuracy Verification Examples Manual” [10]. This article discusses the analysis that the Autodesk Simulation software can perform such as stress analysis, deflection analysis and vibration analysis which we really need to do. It also compares the result of the software with the theoretical value for each of the analysis. The errors for all of the analysis that are related to our project have less than 1% error. This is a good indicator that we can use the result from Autodesk Simulation software as our starting point.

## **References**

- [1] *About Us*. Coherix, 2012. Web. 20 Sept. 2012. <<http://coherix.com/pages/About-Us>>.
- [2] ASTM B221-12, 2012, Standard Specification for Aluminum and Aluminum-Alloy Extruded Bars, Rods, Wire, Profile, and Tubes, ASTM International, West Conshohocken, PA, DOI:10.1520/B0221-12.
- [3] A. Alfsen, Thomas P. Bluit. XY Table . United States: Patent 3495519. 17 February 1970.
- [4] Morita, Kunihiko. Double Rail Linear Motion Guide Assembly. United States: Patent 5244283. 14 September 1993.
- [5] W. Thomas Novak, Zahirudeen Premji, Uday G. Nayak, Akimitsu Ebihara. Precision Scanning Apparatus and Method with Fixed and Movable Guide Members. United States: Patent 6363809. 2 April 2002.
- [6] Richard J. Speranza, Richard A. Speranza. X-Y Movement Mechanism. United States: Patent 5341700. 30 August 1994.
- [7] Lincoln Davidson. Accelerometer Based Tilt Sensor and Method for Using Same. United States: Patent 7231825B2. 19 June 2007.
- [8] Kaoru Iguchi, Masakazu Takahashi. Ball Transfer Unit and Ball Table. United States: Patent 7370746B2. 13 May 2008.
- [9] Beards, C. F. *Structural Vibration: Analysis and Damping*. London: Arnold, 1996.

[10] Autodesk Inc., . *Autodesk Simulation Accuracy Verification Examples Manual*. 2012th ed. Autodesk Inc., 2012.

[11] Dassault Systemes. *Viscous Damping Ratio*. N.p., n.d. Web. 1 Nov. 2012.  
<[http://help.solidworks.com/2012/English/SolidWorks/cworks/Viscous\\_Damping\\_Ratios.htm](http://help.solidworks.com/2012/English/SolidWorks/cworks/Viscous_Damping_Ratios.htm)

**Appendix A: Bill of Materials**  
**Table A.1**

<b>Purchased Materials</b>							
Part Name	Qty	Material	Dimensions	Function	Part #	Supplier	Total Cost
Aluminum Plate	1	6061-T6 Aluminum	8" x 3' x 0.25"	Transfer Plate	1614T493	SpeedyMetals.com	\$ 41.88
Ball Transfer Unit	3	Stainless Steel	5/8" Dia. Ball	Sensor Motion	6460K21	McMaster.com	\$ 24.45
Foam Seal	1	EPDM	3/16 x x 10'	Soft Stop	288233	Carpenter Bros. Hardware Store	\$ 7.73
Acrylic Sheets	4	Acrylic	24" x 24"	Walls	453217	HomeDepot	\$ 41.47
M6 x 35mm Socket Head Screws	20	Steel	M6 x 35mm	Fastener		Carpenter Bros. Hardware Store	\$ 9.54
M6 Nuts	20	Steel	M6	Fastener		Carpenter Bros. Hardware Store	\$ 3.18
Aluminum Square Tubing	1	6063-T5 Aluminum	3/4" x 3/4" x 116"	Sensor Frame	88875K31	SpeedyMetals.com	\$ 35.85
1/4"-20 x 0.5" Bolt	12	Steel	1/4"-20 x 0.5"	Fastener		Carpenter Bros. Hardware Store	\$ 7.58
10/32 x 1.25" Slot-Head Screw	8	Steel	10-32 x 1.25"	Fastener		Carpenter Bros. Hardware Store	\$ 0.96
25 Series 5050 T-Slotted Framing	1	Aluminum	50mm x 50mm x 3983mm	Support Structure	25-5050	ThreedSales.com	\$ 110.42
45° SUPPORT	8	Aluminum	25mm x 25mm x 160mm	Support Braces	25-2565	ThreedSales.com	\$ 88.96
Cut to Length						ThreedSales.com	\$ 13.12
						<b>Totals</b>	<b>\$ 385.13</b>
<b>Donated Materials</b>							
Part Name	Qty	Material	Dimensions	Function	Part #	Supplier	
End Feed Fasteners for 80/20	12	Steel	M6 Screw	Fastener	N/A	Coherix	
Aluminum Square Tubing	1	Aluminum	3/4" x 3/4" x 23" 0.0625	Handlebar	N/A	X50 Assembly	

As shown in the Table A.1 on page XX. The total spent on materials for the project was \$385.13. We used some scrap aluminum tubing we found in the X50 assembly room to fashion a handle bar for our prototype which did not count toward our budget. We also received end feed fasteners from Coherix for the 80/20 extruded tubing.



## Appendix B: Engineering Change Notices

ME450

Team 12

11/20/12

### Engineering Change Notice #1

#### Change Description

Changing the bolts that secure the sensor feet to the plate from M6 to  $\frac{1}{4}$ "x20.

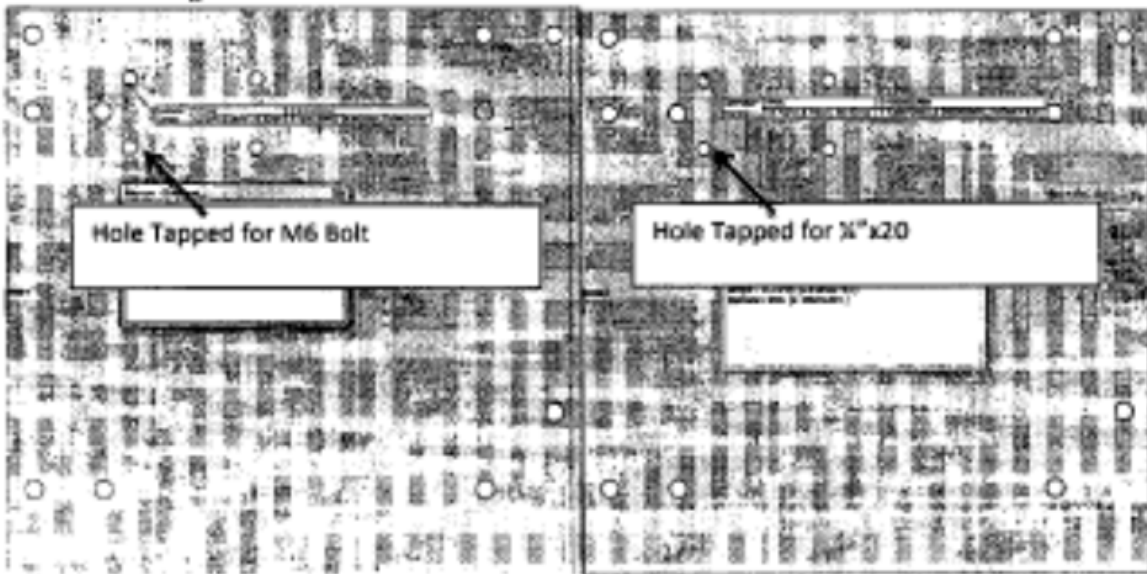
#### Reason for Change:

Machine shop did not have the M6 x 1.0 tap needed to tap the holes in the plate. Therefore, we decided to change to  $\frac{1}{4}$ "x20 bolts because that's the closest size to the M6.

#### Parts Impacted:

Transfer Plates and Bolts

#### Sketch of Change:



ME450  
Team 12  
11/20/12

Engineering Change Notice #2

**Change Description**

Removing the slots in the mounts for the ball mounts and using thru-holes instead

**Reason for Change:**

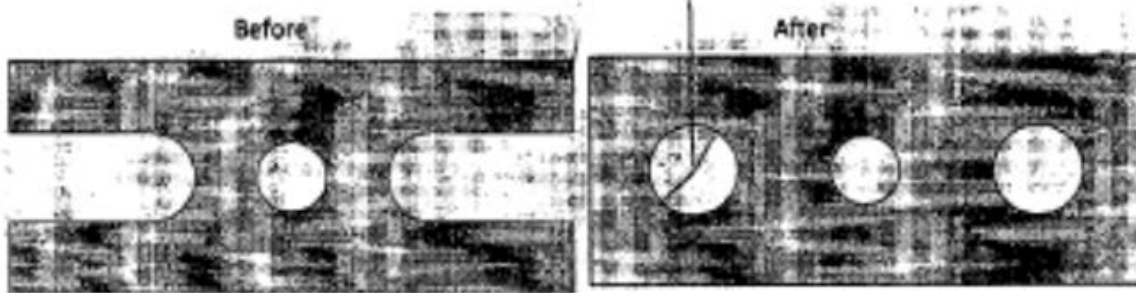
Slots were designed before we knew the actual dimensions of the T-slot aluminum and gave us room to adjust to the actual dimensions. We found the actual dimensions of the T-slot and determined we could use holes instead. The holes reduced part complexity and makes it easier to machine.

The new holes are clearance holes for the M6 Bolts and are 0.2570" diameter.

**Parts Impacted:**

Ball Mounts

**Sketch of Change:**



*[Handwritten signature]*

*[Handwritten signature]*

ME 450  
Team 12  
11/29/12

**Engineering Change Notice #3**

**Change Description:**

Changing the bolts that secure the four hard stops to the sensor's support frame from M6 to #10 x 32.

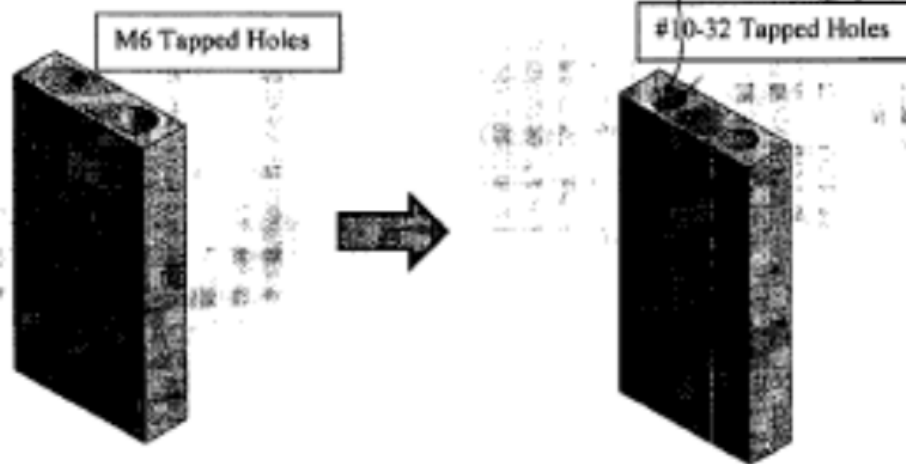
**Reason for Change:**

The larger M6 holes turned out to be too large to drill into the quarter-inch aluminum plate hard stops while retaining their structural integrity. We decided to change to #10 x 32 because they are sufficiently small and the machine shop has these taps readily available.

**Parts Impacted:**

Hard Stops and Bolts

**Sketch of Change:**



*[Handwritten signature]*

*[Handwritten signature]*

**Engineering Change Notice #4**

**Change Description**

Slots added to each of the transfer plates.

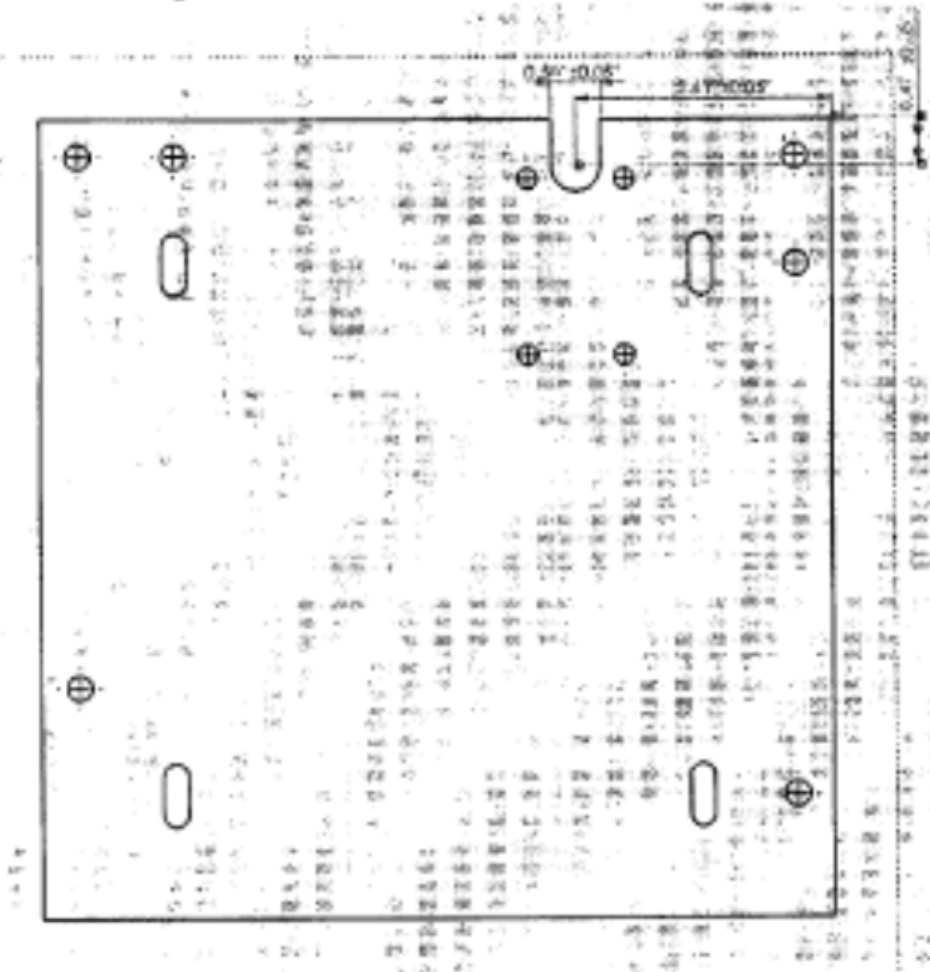
**Reason for Change:**

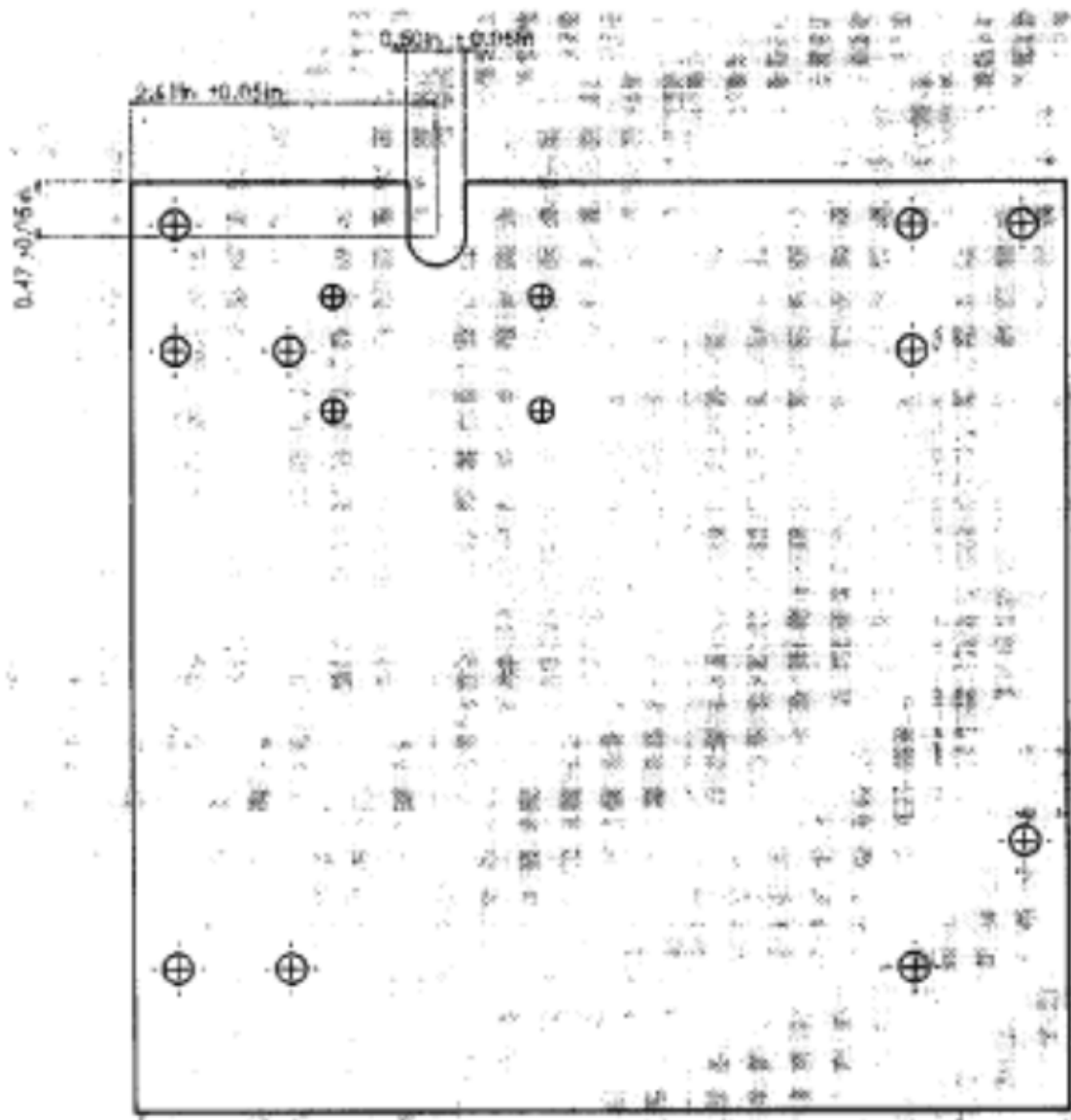
Slots added to reduce the risk of the S150 mounting brackets from colliding with the transfer plates. There is enough clearance is the mounting balls on the S150 are nearly fully extended. This change will give more room for adjusting the mounting balls.

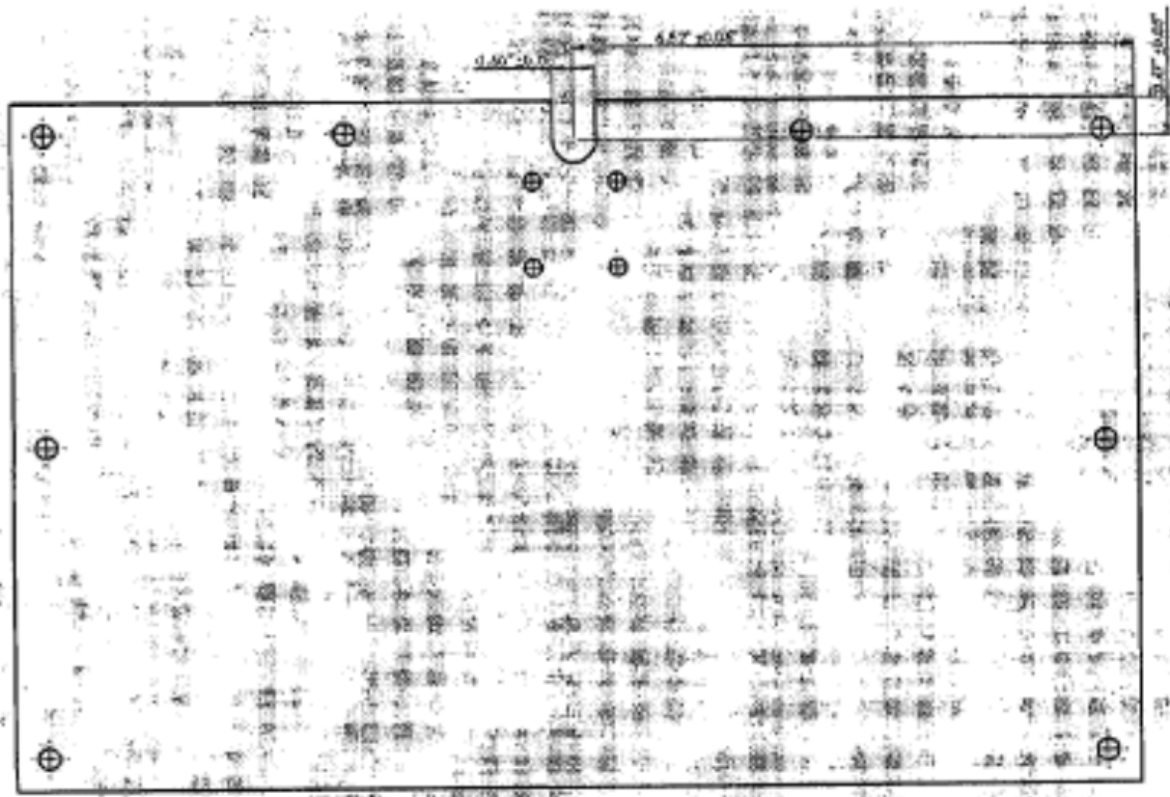
**Parts Impacted:**

All transfer plates

**Sketch of Change:**







Approved By:

Section Instructor:

*[Handwritten Signature]*

Date:

3 Dec 12

Coherix:

*[Handwritten Signature]*

Date:

5 Dec 12

ME450  
Team 12  
12/3/12

**Engineering Change Notice #5**

**Change Description**

1" x 1" notches added to the corners of the acrylic walls and change position of the acrylic

**Reason for Change:**

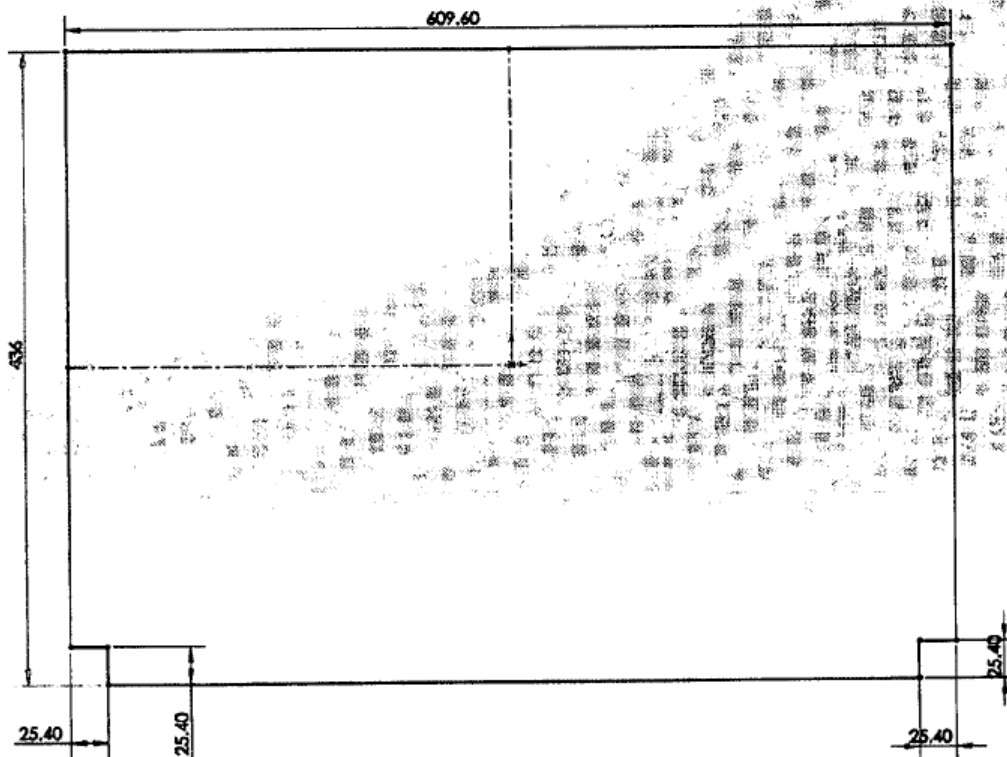
The notches were added so fasteners could be placed beneath the acrylic in the T-slot and hold it in place. The acrylic walls are being inserted in the T-slot extrusions instead of being attached the outside. This will make the structure more visually appealing as well as better secure the acrylic.

**Parts Impacted:**

Acrylic walls

**Sketch of Change:**

Previous design had no notches, the acrylic was just a rectangle.



Approved By:

Section Instructor:

Date:

Coherix:

Date:

ME450  
Team 12  
12/4/12

Engineering Change Notice #6

**Change Description**

Changing the foam bumpers that stop the ball transfer units

**Reason for Change:**

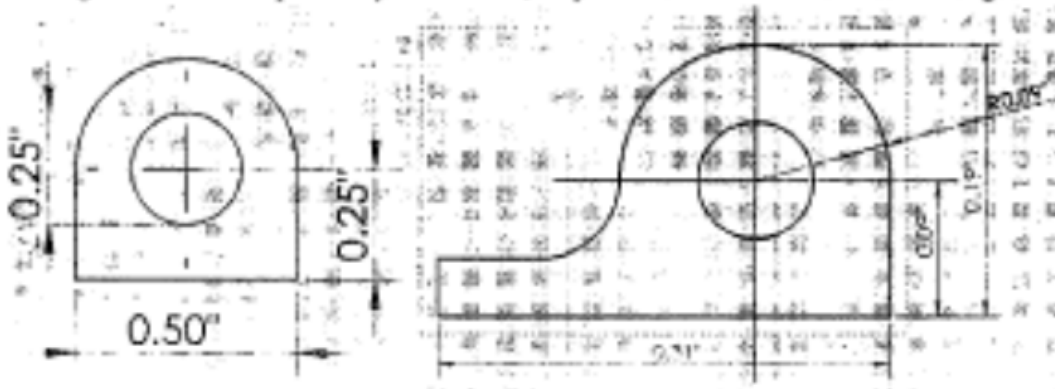
The first foam we used was designed for the initial precision ball transfer units. We changed from the precision grade to commercial grade and did not believe this change would affect the foam. After manufacturing everything, we realized the flange on the top of the ball transfers was larger than expected and the thicker foam would not work. We moved to a thinner and softer foam which works well with the ball transfer units.

**Parts Impacted:**

EPDM Foam

**Sketch of Change:**

The length of each foam piece stayed the same, only the cross-section of the foam changed.



Approved By:

Section Instructor:

Date

41 Dec 12

Coherix:

Date

5 Dec 12



ME450  
 Team 12  
 12/4/12

**Engineering Change Notice #7**

**Change Description**

Adding a handle bar to the front of the sensor frame, made of 3/4" square 6061 aluminum tubing, with 1/16" walls.

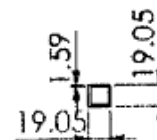
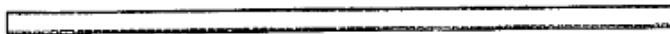
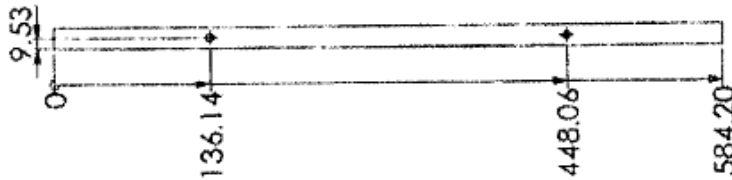
**Reason for Change:**

With the added weight of the sensor on the structure, it can be difficult to move the frame from position to position holding the transfer plates themselves. Adding a handle bar on the larger front plate will help alleviate the navigation process.

**Parts Impacted:**

Handle Bar

**Sketch of Change:**



PROPRIETARY AND CONFIDENTIAL  
 THIS DRAWING IS THE PROPERTY OF THE UNIVERSITY OF MICHIGAN. IT IS TO BE KEPT CONFIDENTIAL AND NOT REPRODUCED OR TRANSMITTED IN ANY FORM OR BY ANY MEANS, ELECTRONIC OR MECHANICAL, INCLUDING PHOTOCOPYING, RECORDING, OR BY ANY INFORMATION STORAGE AND RETRIEVAL SYSTEM.

APPROVED BY: \_\_\_\_\_  
 DATE: \_\_\_\_\_

UNLESS OTHERWISE SPECIFIED:  
 DIMENSIONS ARE IN MILLIMETERS  
 DECIMALS: FRACTIONS  
 ANGULAR DIMENSIONS: DECIMALS  
 TOLERANCES: FRACTIONS  
 SURFACE FINISH: RA 1.6  
 MATERIAL: 6061 ALUMINUM TUBING  
 FINISH: ANODIZED

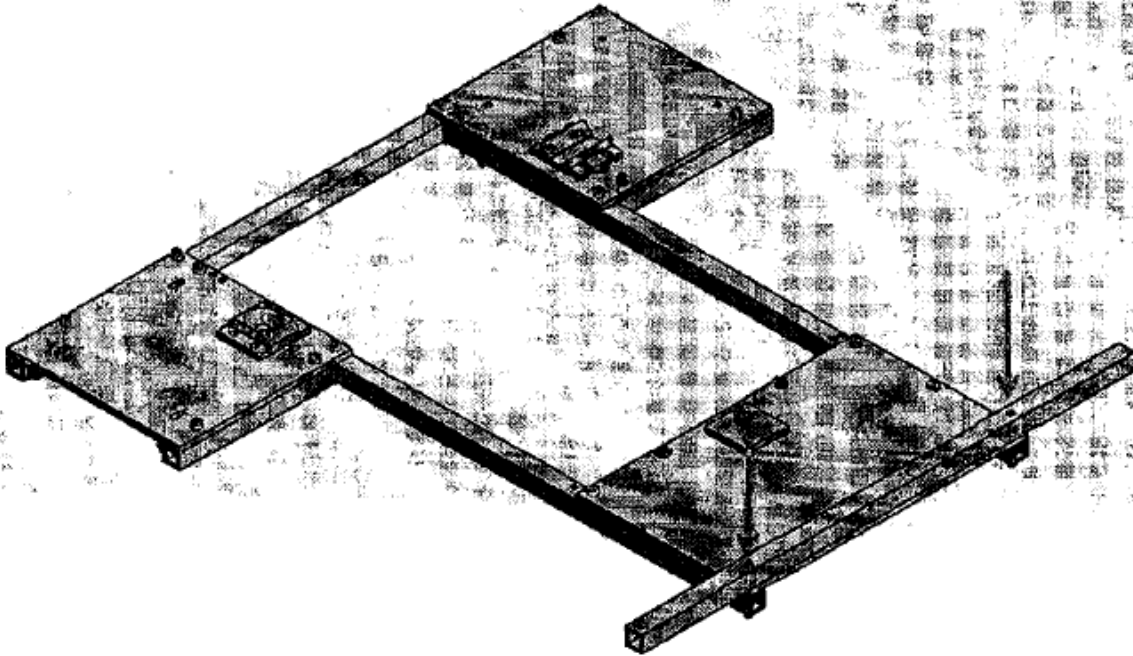
NAME: \_\_\_\_\_ DATE: \_\_\_\_\_

TITLE: **Handle Bar**

SIZE: A DWG. NO. **ME 450 12-17** REV. \_\_\_\_\_  
 SCALE: 1:4 WEIGHT: \_\_\_\_\_ SHEET 1 OF 1

5 4 3 2 1

Location of handle bar on sensor frame:



Approved By:

Section Instructor:



Date:

6 Dec 12

Sponsor:



Date:

5 Dec 12

## Appendix C: Design Analysis

### Material Selection (Functional Performance)

In this section, we are going to determine the best materials for our project. We use CES EduPack 2012 software to analyze and compare the pool of materials available to us. After that, we will decide the materials which are the best for our project.

#### Sensor Frame Beams:

In our structure, the beams are one of the most important components. The beams must have high stiffness while the mass and the price must be minimize. We specified this objective and constraints so that we can meet our engineering specifications. We also wanted the material to have high fracture toughness so that the structure will not fail if it experiences a high shock input.

Function: Beams under a specified load

Objective: High stiffness

Constraints: a) Low density

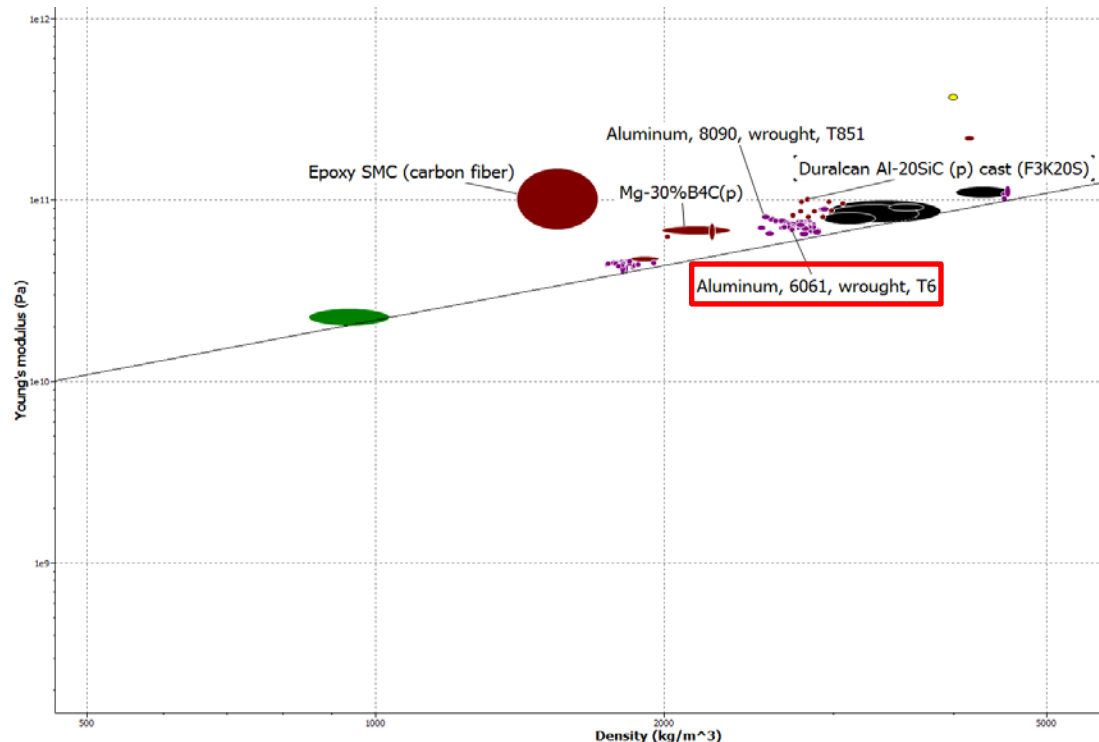
b) Price,  $C_m < \$13.5/\text{kg}$

c) Length specified

d) Fracture toughness  $> 10\text{MPa}\cdot\text{m}^{0.5}$  (non-brittle materials)

Material Index:  $M1 = E/\rho$

**Figure C1:** Young's modulus against density for various applicable materials. The chosen material was 6061 T-6 aluminum

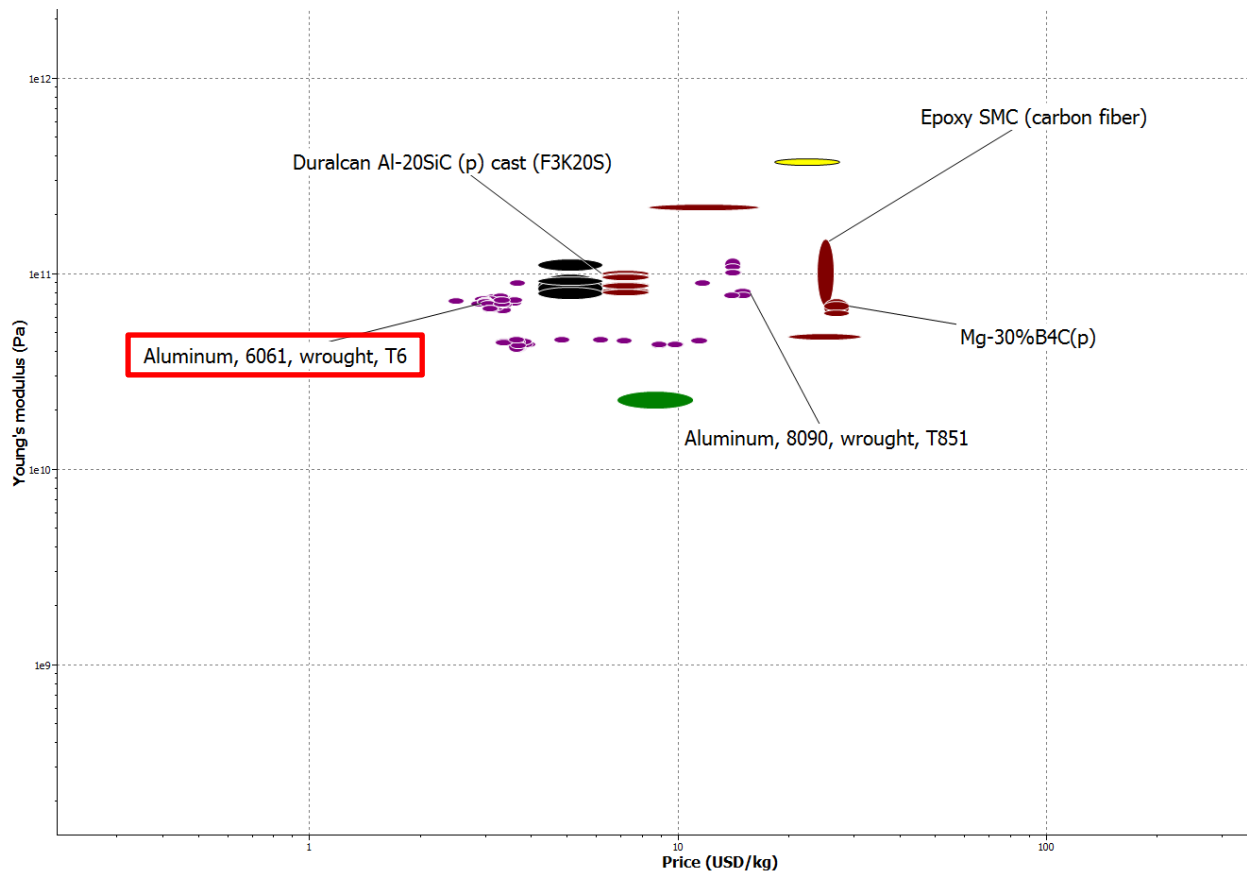


In Figure C1, we plotted Young's modulus against density. We also plotted a straight line with a slope of 1 so that we can determine the materials that maximize the material index, M1. The farther a material is from this line, the higher the value of M1. If the distances between the two different materials and the straight line are the same, we will choose the material that has lower density to minimize weight. We also apply limits to include the other constraints such as price and fracture toughness.

Based on Figure C1, top five material choices are:

- 1) Epoxy SMC (carbon fiber)
- 2) Duralcan Al-20SiC (p) cast (F3K20S)
- 3) Aluminum 8090-T851
- 4) Mg-30%B4C(p)
- 5) Aluminum 6061-T6

**Figure C2:** Young's modulus against price for the same materials.



In Figure C2, we plotted Young's modulus against the price per kilogram to compare the price of each of the material choices. From this figure, we will choose the cheapest material because of our budget constraint of \$400. The best material based on this data for beams is aluminum 6061-T6. Unfortunately, we were unable to find the aluminum tubes in the size we required in 6061-T6 aluminum. Instead we used 6063-T5 aluminum. This alloy is not as stiff, but it was cheaper and provided the same density.

## Transfer Plates:

In our structure, the transfer plates are vital components that we needed to determine the best material to be used. The plates will experience bending moment and load. The plates also will need to roll on stainless steel ball bearings. The plates must have high stiffness but at the same time, the mass and the price must be minimized. We specified this objective and constraints so that we can meet our engineering specifications. We also want the material to have high fracture toughness so that the structure will not fail if it experiences a high shock input. We also specify that the plates must be as hard as stainless steel or more. This is to prevent stainless steel ball bearings from scratching the plates or wearing over time.

Function: Beams under a specified load and can roll on top of steel ball bearings.

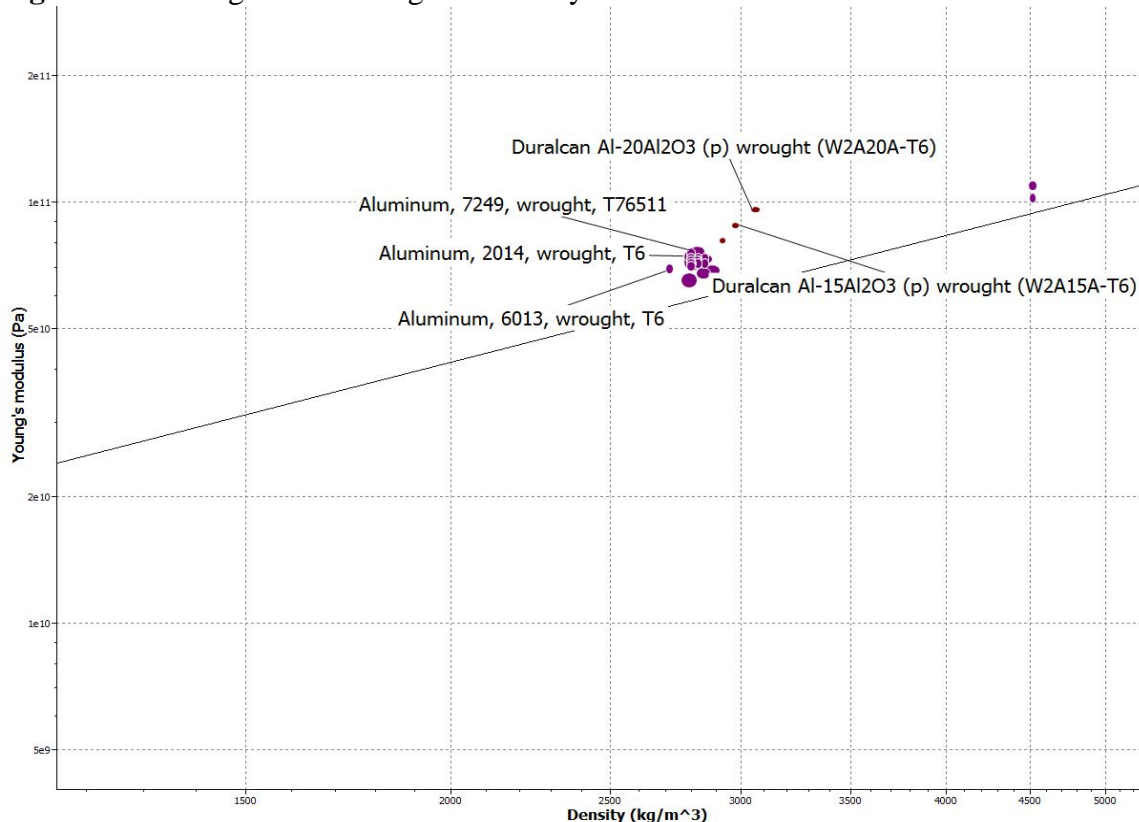
Objective: High stiffness

Constraints:

- Low density
- Price,  $C_m < \$13.5/\text{kg}$
- Length specified
- Fracture toughness  $> 10\text{MPa}\cdot\text{m}^{0.5}$  (non-brittle materials)
- Hardness-Vickers  $> 2\text{GPa}$  (must be equal or higher than the hardness of stainless steel used in ball bearings).

Material Index,  $M2 = E/\rho$

**Figure C3:** Young's modulus against density

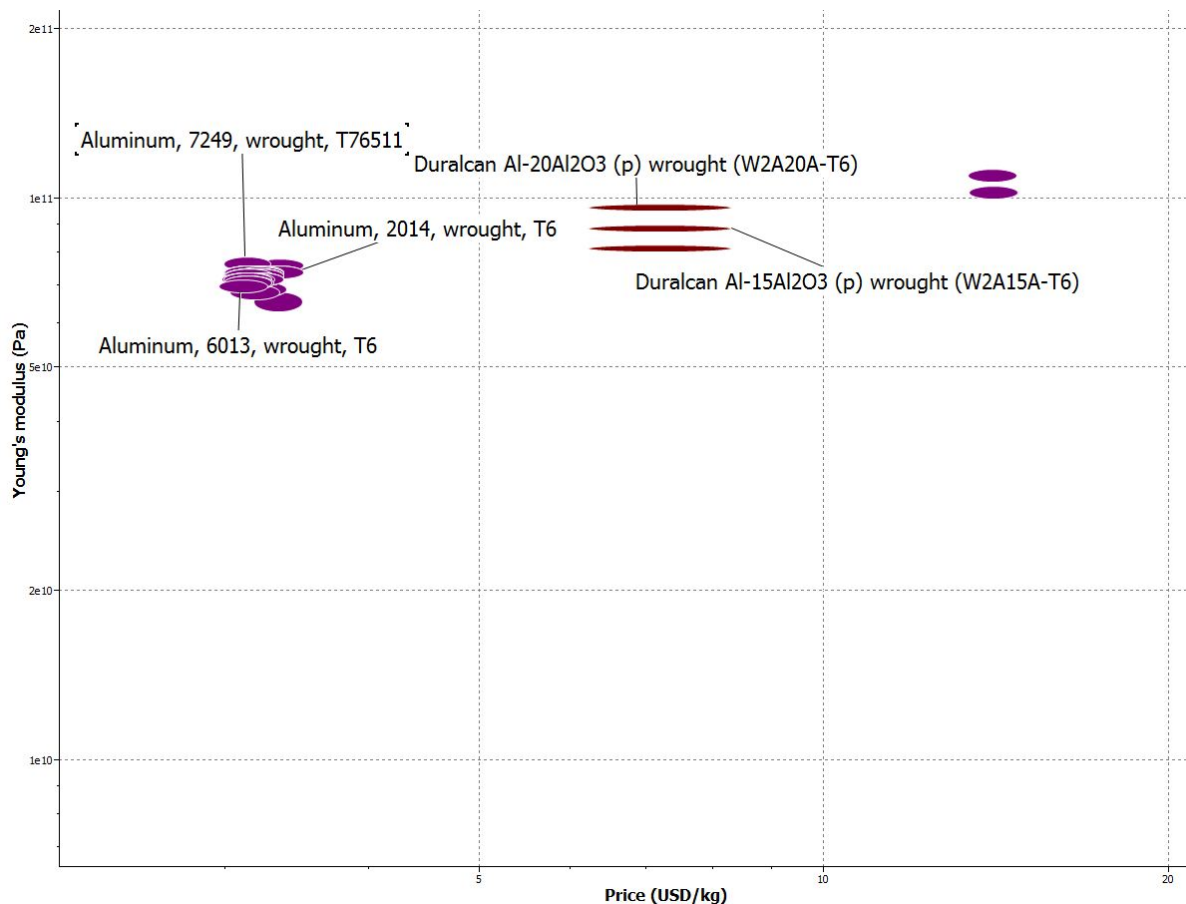


In Figure C3, we plotted Young's modulus against density. We also plotted a straight line with a slope of 1 so that we can determine the materials that maximize the material index, M1. The farther a material is from the straight line, the higher the value of M1. If the distances between the two different materials and the straight line are the same, we will choose the material that has lower density to minimize weight. We also applied limits to include the other constraints such as price, fracture toughness and hardness.

Based on Figure C3, top five material choices are:

- 1) Duralcan Al-20Al2O3 (p) wrought (W2A20A-T6)
- 2) Duralcan Al-15Al2O3 (p) wrought (W2A15A-T6)
- 3) Aluminum 7249-T76511
- 4) Aluminum 2014-T6
- 5) Aluminum 6013-T6

**Figure C4:** Young's Modulus against Price



In Figure C2, we plotted Young's modulus against price to compare the price of each of the material choices. From this figure, we will choose the cheapest material in order to minimize cost. The best material for the plates is aluminum 6013-T6. Unfortunately, we were unable to find a plate of aluminum with the required thickness that we need. The thinnest plate we could

find of this alloy was 0.5”, double of what was required. This would double the weight of the transfer plates and significantly increase the cost. In addition, the increased hardness over other types of aluminum would have proved to be more difficult to manufacture. Because of that, we choose to use aluminum 6061-T6 instead. 6061-T6 gave us adequate stiffness, price and density; however, it did not meet the hardness specification. To combat this, we recommend that the transfer plates be hard-coat anodized. This anodizing will significantly increase the hardness and prevent wear on the plate from the stainless steel ball bearing.

### Conclusion:

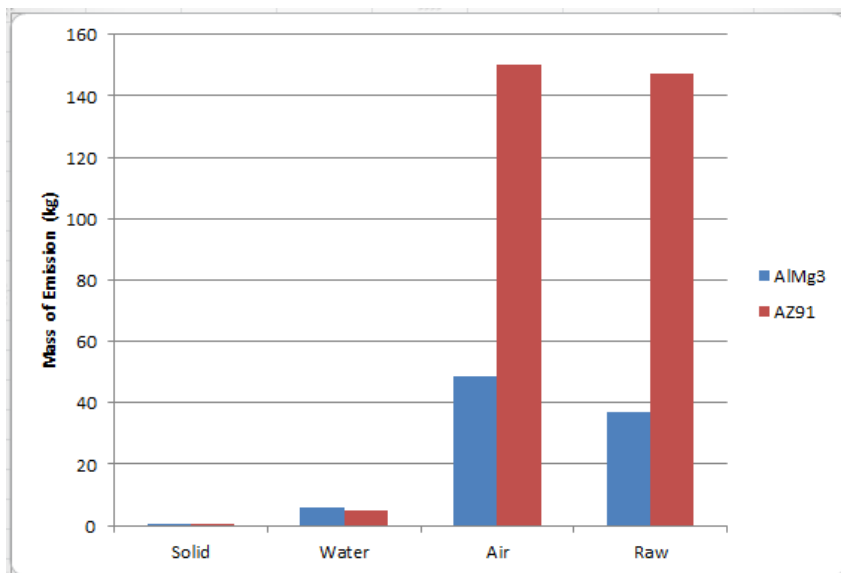
We use CES EduPack 2012 software to determine the best materials for our project. We will use aluminum 6063-T5 to manufacture the beams. We will also use aluminum 6061-T6 to manufacture the ball transfer plates.

### Material Selection (Environmental Performance)

In this section, we are going to analyze and compare environmental performance between two material choices that we decide in material selection section. The materials are Aluminum 6061-T6 and Mg-30%B4C(p). We will use SimaPro 7.3.3 software to do the analysis. Unfortunately, this software’s database does not have the material that we specify. Because of that, we will compare the environmental performance between AlMg3 aluminum alloy and AZ91 magnesium alloy. We also specified the mass of material that we need to use in our project which is 14kg.

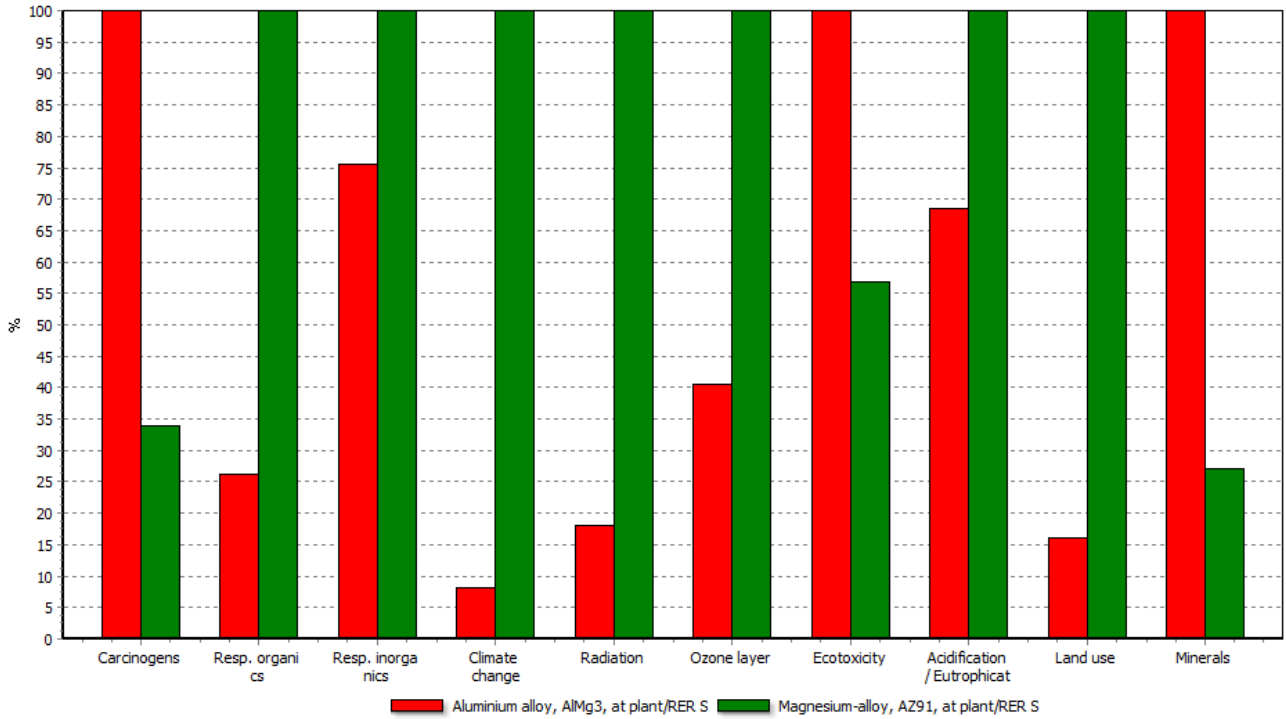
- Materials to compare:
  - a) Aluminum 6061-T6 (AlMg3 aluminum alloy)
  - b) Mg-30%B4C(p) (AZ91, magnesium alloy)
- Mass: 14kg

**Figure C5:** Total Emission with Respect to Emission Categories



From Figure C5, we can see that magnesium alloy produce more emission in air and raw category with a very large margin, 101.5kg and 110.6kg respectively. Magnesium alloy also produces more emission in solid category with a very small margin, 0.06kg. Aluminum alloy produces more emission only in water category with small margin, 0.84kg.

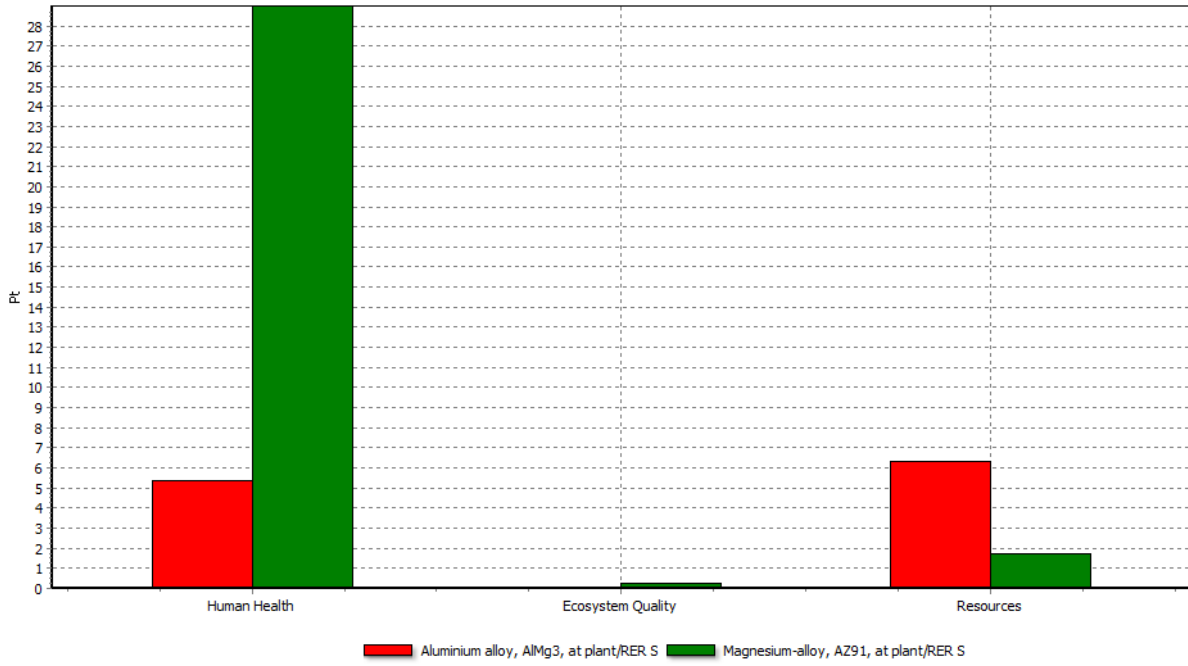
**Figure C6: Relative Impacts in Disaggregated Damage Categories**



Comparing 14 kg 'Aluminium alloy, AlMg3, at plant/RER S' with 14 kg 'Magnesium-alloy, AZ91, at plant/RER S';  
 Method: Eco-indicator 99 (I) V2.08 / Europe EI 99 I/I / Characterization

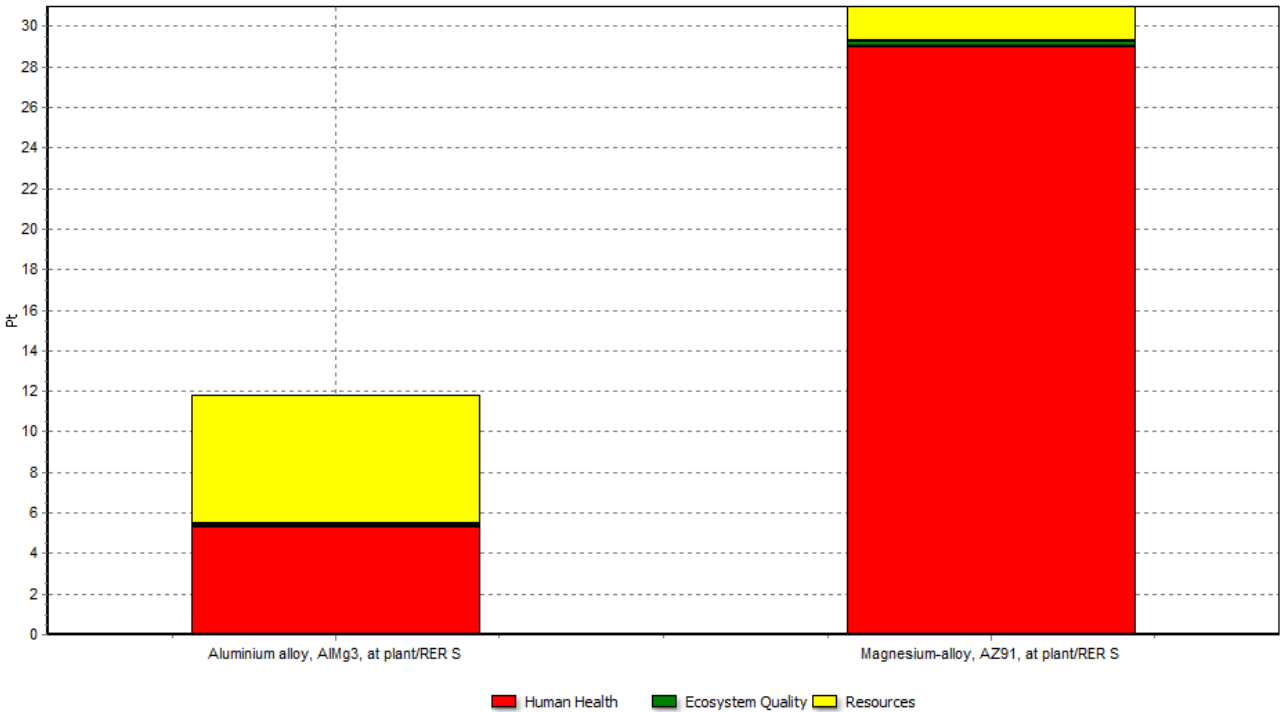


**Figure C7:** Normalized Score in Human Health, Eco-Toxicity, and Resource Categories



Comparing 14 kg 'Aluminium alloy, AlMg3, at plant/RER S' with 14 kg 'Magnesium-alloy, AZ91, at plant/RER S';  
Method: Eco-indicator 99 (I) V2.08 / Europe EI 99 I/I / Weighting

**Figure C8:** Single Score Comparison of the Impact of Processing AlMg3 and AZ91 to Human Health, Ecosystem Quality and Resources.



Comparing 14 kg 'Aluminium alloy, AlMg3, at plant/RER S' with 14 kg 'Magnesium-alloy, AZ91, at plant/RER S';  
Method: Eco-indicator 99 (I) V2.08 / Europe EI 99 I/I / Single score

The most important damage meta-category is human health. As we can see in Figure C8, the productions of magnesium alloy greatly affect human health as compared to the production of aluminum alloy. Figure C6 shows that the productions of the magnesium alloy produce a greater health damaging pollution such as respiratory organics, respiratory inorganics and radiation.

Also from figure C8, the production of magnesium alloy has the highest Ecoindicator 99 point value because it greatly affects the health of human. The magnesium alloy and aluminum alloy had a point values of about 31 and 12, respectively.

If we consider the life cycle of the whole product, aluminum alloy is still the best choice. This is because it has a very long life cycle, which is about 10 to 15 years. At the end of its life, at the end of its life, it can be recycle with less cost and energy usage. For magnesium alloy, it also has a very long life cycle and can be recycle at the end of its life, but the cost to recycle is the same as manufacture the new ingot and it still produce high amount of damaging pollution.

### **Conclusion:**

After evaluating the environmental performance of each of the materials, we decide to use aluminum alloy instead of magnesium alloy. This is because the productions of aluminum alloy produce a lot less health damaging pollution and because of that, it is safer to human being.

### **Manufacturing Process Selection**

Our structure is a demonstration unit for Coherix to show the capabilities of its new S150 sensor. Coherix has said the production volume of the demonstration units would be very low, less than 50 per year. In this section, we will use CES Manufacturing Process Selector to determine the best method to produce 50 units of the structure.

### **Sensor Frame Beams:**

For this components, we need a manufacturing process that has high precision and economically feasible. The material used in this analysis is aluminum 6063-T6. The quantity that needs to be produced is 300. In CES Manufacturing Process Selector, we specify the shape to be non-circular prismatic, and the process characteristics to be machining processes.

**Figure C9: Economic Batch Size against Tolerance**

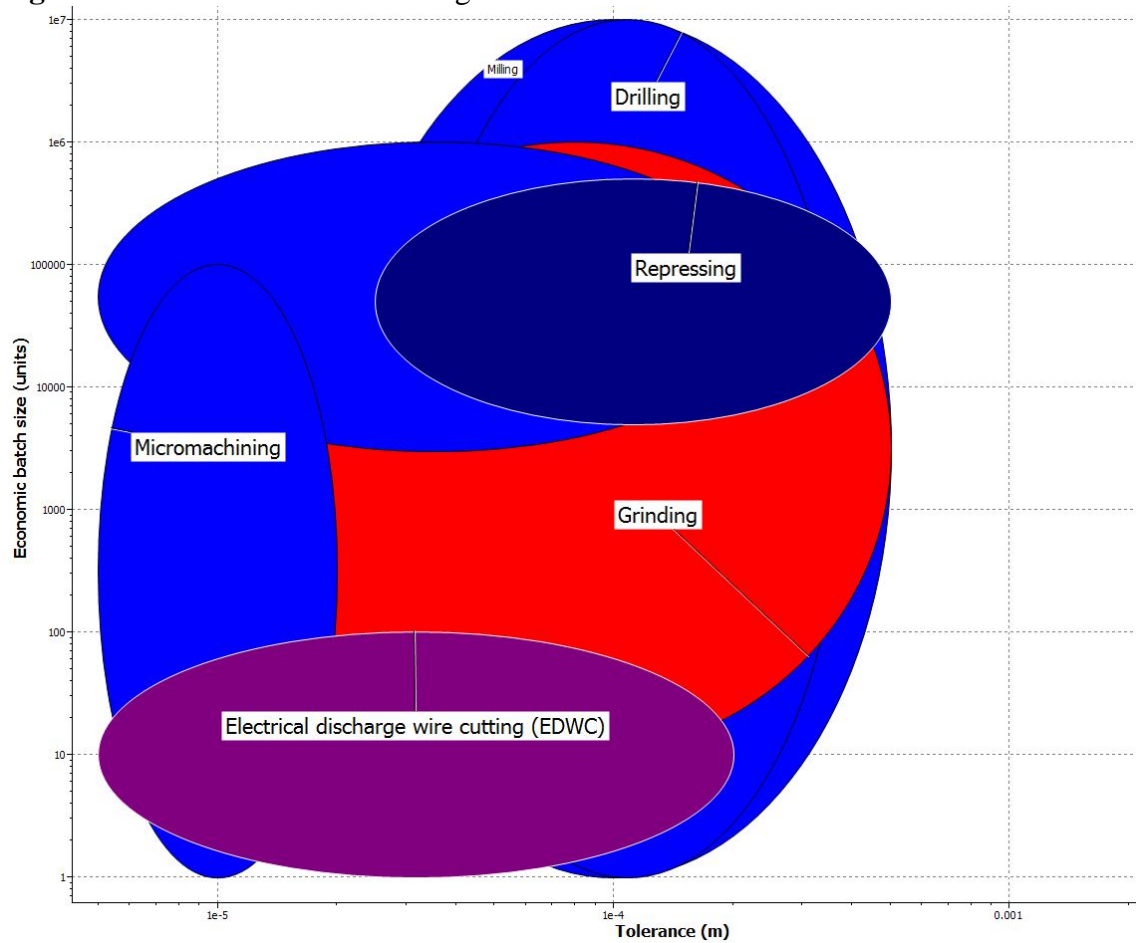


Figure C9 shows the economically feasible manufacturing process for this component. It also shows the tolerance that can be achieved by each of the manufacturing processes. For sensor frame beams, the best manufacturing process is milling because it is economically feasible to produce 300 units of beams and it can achieve the proper tolerance. Based on the figures, micro machining looks the best; however, it cannot machine necessary section thickness of the beams. Therefore, milling is the best because of its versatility and it meets the requirements.

**Ball Transfer Plates:**

For this components, we need a manufacturing process that has high precision and economically feasible. The material used in this analysis is aluminum 6061-T6. In CES Manufacturing Process Selector, we specify the shape to be flat sheet, and the process characteristics to be cutting and machining processes.

**Figure C10: Economic Batch Size against Tolerance**

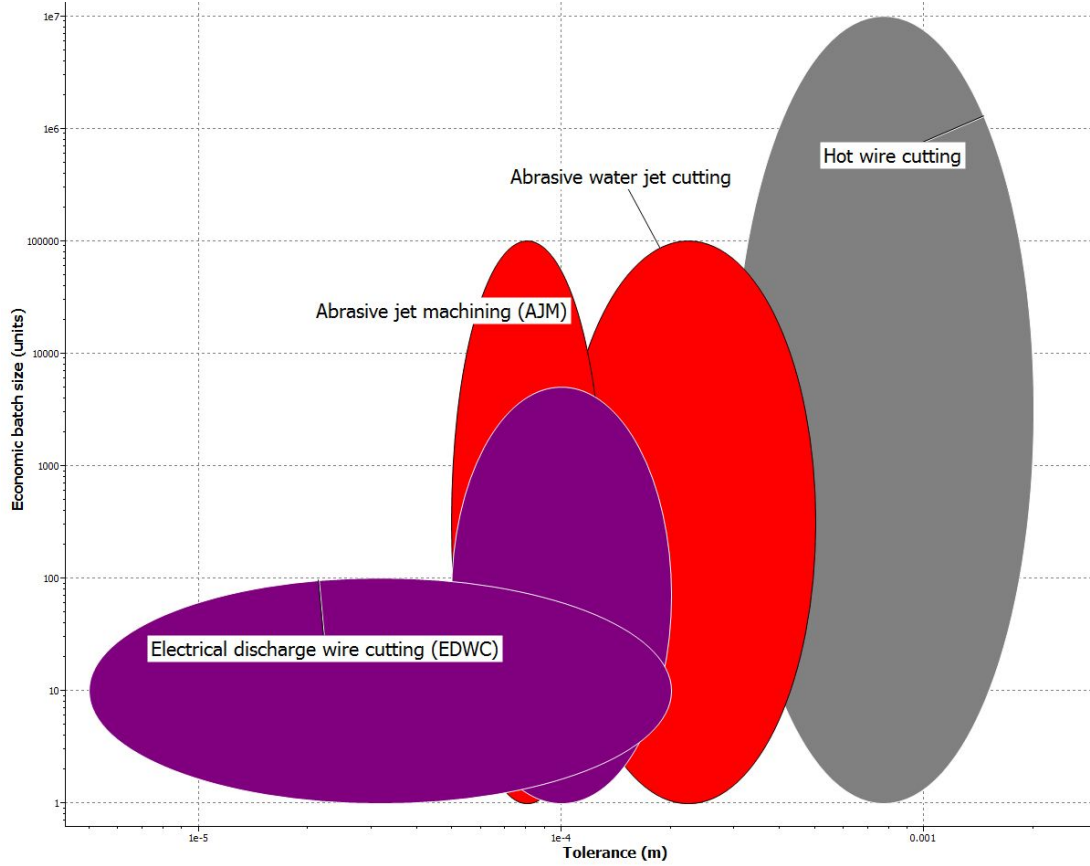


Figure C10 shows the economically feasible manufacturing process for this component. It also shows the tolerance that can be achieved by each of the manufacturing processes. For ball transfer plates, the best manufacturing process is abrasive jet machining (AJM) because it is economically feasible to produce 150 units of plates and it can achieve less than 0.0001m tolerance.

**Conclusion:**

We use CES Manufacturing Process Selector to determine the best manufacturing process for each of our important components. For ball transfer plates, the best machining process is abrasive jet machining (AJM). For top structure beams, the best machining process is milling.

## Appendix D: Quality Function Deployment

System QFD															
1	Vibration Amplitude (-)														
2	Structure's Natural Frequency (+)	+													
3	Accuracy in x,y directions of Sensor (+)														
4	Accuracy in z Direction of Sensor (+)	+													
5	Accuracy in Rotation Angle of Sensor (+)														
6	Availability of Parts (+)														
7	Lead Times (-)									++					
8															
9	Max Speed of Sensor (-)														
10	Weight of Structure (-)	+	+												
11	Structure Size (-)	+	+												
12	Safety Factor on Strength (+)											+	+		
13	Moment Required to Tilt Structure (+)											+	+		
14	Deflection of Horizontal Support Beams (-)						++	+							
15															

Technical Requirements																
Customer Needs	Customer Weights	Kano Type	Vibration Amplitude (-)	Structure's Natural Frequency (+)	Accuracy in x,y directions of Sensor (+)	Accuracy in z Direction of Sensor (+)	Accuracy in Rotation Angle of Sensor (+)	Availability of Parts (+)	Lead Times (-)	Max Speed of Sensor (-)	Weight of Structure (-)	Structure Size (-)	Safety Factor on Strength (+)	Moment Required to Tilt Structure (+)	Deflection of Horizontal Support Beams (-)	
1	Repeatability	3	B	9	9	3	3						5	9		
2	Safety	8	B	5	5					9	3		9	3		
3	Sensor Face at Fixed Height	8	B	9	5		3						9	9		
4	Sensor Face Level and Square	8	L					9						7		
5	Simplicity	8	B			5		9	9			3	5			
6	Low Manufacturing Cost	7	D			5	5	7	5	5	3	3	5	5		
8	Appearance	5	D													
9	Accurate Positioning System	5	D			9	9					1				
10	Cable Management	3	D						1	1		1				
11	Mobility	3	L						3	5	3	7		7		
	<b>Raw score</b>			133	161	147	131	121	119	125	102	69	85	152	133	
	<b>Scaled</b>			0.63	0.69	0.63	0.56	0.52	0.51	0.54	0.44	0.3	0.36	0.65	0.57	
	<b>Relative Weight</b>			11%	9%	8%	7%	7%	7%	7%	6%	4%	5%	9%	8%	
	<b>Rank</b>			2	3	5	7	9	10	8	11	13	12	4	6	
	<b>Kano</b>		B	B	L	L	L	L	L	D	D	L	B	B	B	
	<b>Direction</b>		+	+	+	+	+	+	-	+	+	+	+	+	+	
	<b>Technical Requirement Units</b>		um	Hz	mm	mm	degree	s	1-5	weeks	mm/l's	lbs	m <sup>3</sup>	( )	Nm	mm
	<b>Technical Requirement Targets</b>															
	<b>Technical Requirement USL</b>		0.1		1	5	0.5			3	N/A	35	0.76			5
	<b>Technical Requirement LSL</b>			30										2	N/A	

## Appendix E: Concept Generation

From the functional decomposition on page 11, we created six major functions that the demonstration unit must accomplish in order to be considered a success. The six functions are, the support structure, a mechanism to move the sensor, a method of fixing the sensor in location, knowing if the sensor is in location, measuring the tilt of the sensor, and protecting against the environment. For each of these functions we brainstormed and came up with many design ideas. Table B.1 below lists all the concepts we generated during the design process.

**Table E.1:** Concepts Generated

<b>Support Structure</b>	<b>Sensor Movement</b>	<b>Sensor Fixture</b>
4 legged structure	standard xy table	toggle clamp
3 legged structure	independent axis xy table	screws
cantilever arm	thermal expansion	pin
pulleys and ropes	cantilever arm	latch
gyroscope	telescoping arms	mechatronic brakes/ electric motors
rocket engine	hydraulics/pneumatic	magnets
hot air balloon	cart	brake pads
	piezoelectric stack	
	ball bearings	
	gantry	
<b>Location Measurement</b>	<b>Tilt Measurement</b>	<b>Protection From Environment</b>
Laser	Laser sensor	folding curtain
Ultrasound	piezoelectrics	hard case
Hard Stops	accelerometer	black holes
Go/no-go	bubble level	blinds
measuring tape	digital level	shutters
proximity sensors		
buttons/switches		
cable transducers		

## **Appendix F: Manufactured Part Drawings**

Appendix D contains all of the engineering drawings for all the parts that we will manufacture in the machine shop. There are 17 part drawings, numbered from 12-1 to 12-17.

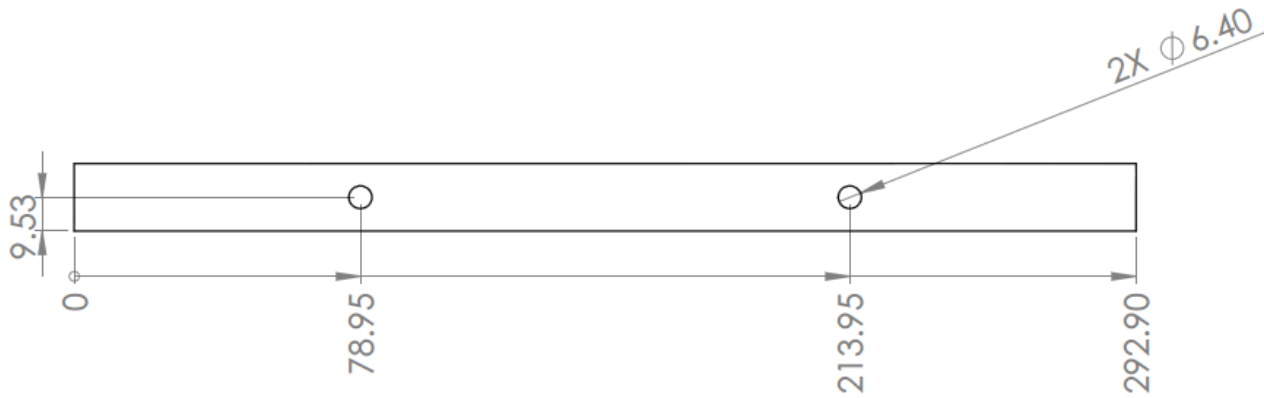
Drawings 1-4 are of the aluminum square tubing used for the sensor frame.

Drawings 5-8 are made from the stock aluminum plate.

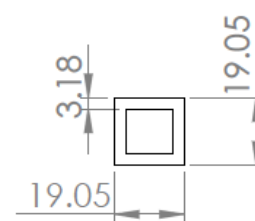
Drawings 9-12 are the acrylic sheets used to protect the apparatus from the environment.

Drawings 13-16 are the extruded T-slot aluminum that make up the support structure.

Drawing 17 is the handle bar, which was made from scrap tubing found in the machine shop.



LENGTH TOLERANCE IS +0/ -0.4mm  
 GENERAL TOLERANCES:  
 .xx ± 0.10mm



**PROPRIETARY AND CONFIDENTIAL**  
 THE INFORMATION CONTAINED IN THIS DRAWING IS THE SOLE PROPERTY OF <INSERT COMPANY NAME HERE>. ANY REPRODUCTION IN PART OR AS A WHOLE WITHOUT THE WRITTEN PERMISSION OF <INSERT COMPANY NAME HERE> IS PROHIBITED.

		UNLESS OTHERWISE SPECIFIED:	NAME	DATE
		DIMENSIONS ARE IN MILLIMETERS	DRAWN	
		TOLERANCES:	CHECKED	
		FRACTIONAL ±	ENG APPR.	
		ANGULAR: MACH ± BEND ±	MFG APPR.	
		TWO PLACE DECIMAL ±	Q.A.	
		THREE PLACE DECIMAL ±	COMMENTS:	
		INTERPRET GEOMETRIC TOLERANCING PER:		
		MATERIAL		
		6063 Aluminum		
		FINISH		
		None		
		DO NOT SCALE DRAWING		
NEXT ASSY	USED ON			
APPLICATION				

TITLE:  
**Sensor Support-Front**

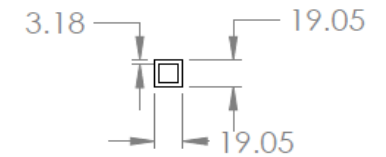
SIZE	DWG. NO.	REV
<b>A</b>	<b>ME 450 12-1</b>	
SCALE: 1:2	WEIGHT:	SHEET 1 OF 1





LENGTH TOLERANCE IS +0/ -0.4mm

GENERAL TOLERANCES:  
.xx ± 0.10mm



**PROPRIETARY AND CONFIDENTIAL**  
THE INFORMATION CONTAINED IN THIS DRAWING IS THE SOLE PROPERTY OF <INSERT COMPANY NAME HERE>. ANY REPRODUCTION IN PART OR AS A WHOLE WITHOUT THE WRITTEN PERMISSION OF <INSERT COMPANY NAME HERE> IS PROHIBITED.

		UNLESS OTHERWISE SPECIFIED:	NAME	DATE	
		DIMENSIONS ARE IN MILLIMETERS	DRAWN		TITLE: <b>Sensor Support-Back</b>
		TOLERANCES:	CHECKED		
		FRACTIONAL ±	ENG APPR.		
		ANGULAR: MACH ± BEND ±	MFG APPR.		
		TWO PLACE DECIMAL ±	Q.A.		SIZE DWG. NO. REV <b>A ME 450 12-2</b>
		THREE PLACE DECIMAL ±	COMMENTS:		
		INTERPRET GEOMETRIC TOLERANCING PER:			SCALE: 1:5 WEIGHT: SHEET 1 OF 1
		MATERIAL <b>6063 Aluminum</b>			
		FINISH <b>None</b>			
NEXT ASSY	USED ON	APPLICATION			
		DO NOT SCALE DRAWING			

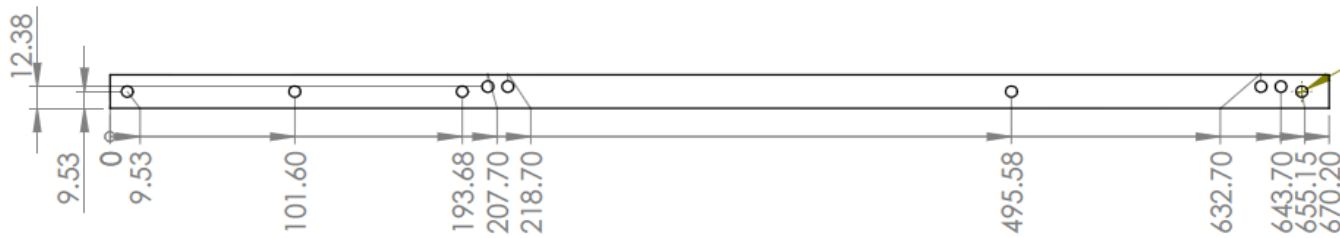
5

4

3

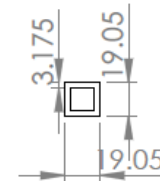
2

1



9X Ø 6.40 M6 THRU

LENGTH TOLERANCE IS +0/ -0.4mm  
 GENERAL TOLERANCES:  
 .xx ± 0.10mm



**PROPRIETARY AND CONFIDENTIAL**  
 THE INFORMATION CONTAINED IN THIS DRAWING IS THE SOLE PROPERTY OF <INSERT COMPANY NAME HERE>. ANY REPRODUCTION IN PART OR AS A WHOLE WITHOUT THE WRITTEN PERMISSION OF <INSERT COMPANY NAME HERE> IS PROHIBITED.

		UNLESS OTHERWISE SPECIFIED:		NAME	DATE		
		DIMENSIONS ARE IN MILLIMETERS		DRAWN		TITLE:	
		TOLERANCES:		CHECKED		Sensor Support-Side	
		FRACTIONAL ±		ENG APPR.			
		ANGULAR: MACH ± BEND ±		MFG APPR.			
		TWO PLACE DECIMAL ±		Q.A.			
		THREE PLACE DECIMAL ±		COMMENTS:			
		INTERPRET GEOMETRIC TOLERANCING PER:				SIZE	DWG. NO.
		MATERIAL				<b>A</b>	ME 450 12-3
		6063 Aluminum					REV
		FINISH					
		None					
NEXT ASSY	USED ON						
APPLICATION		DO NOT SCALE DRAWING				SCALE: 1:4	WEIGHT:
						SHEET 1 OF 1	

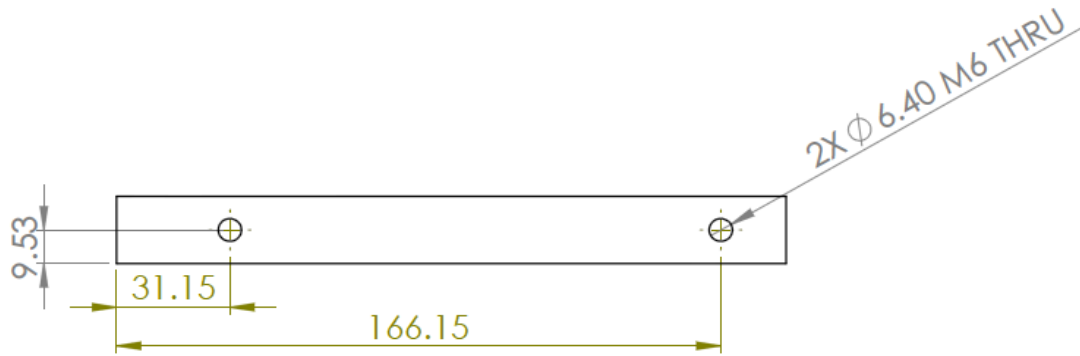
5

4

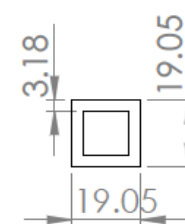
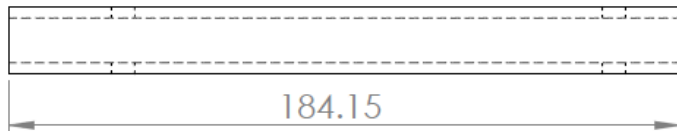
3

2

1



LENGTH TOLERANCE IS +0/ -0.4mm  
 GENERAL TOLERANCES:  
 .xx ± 0.10mm

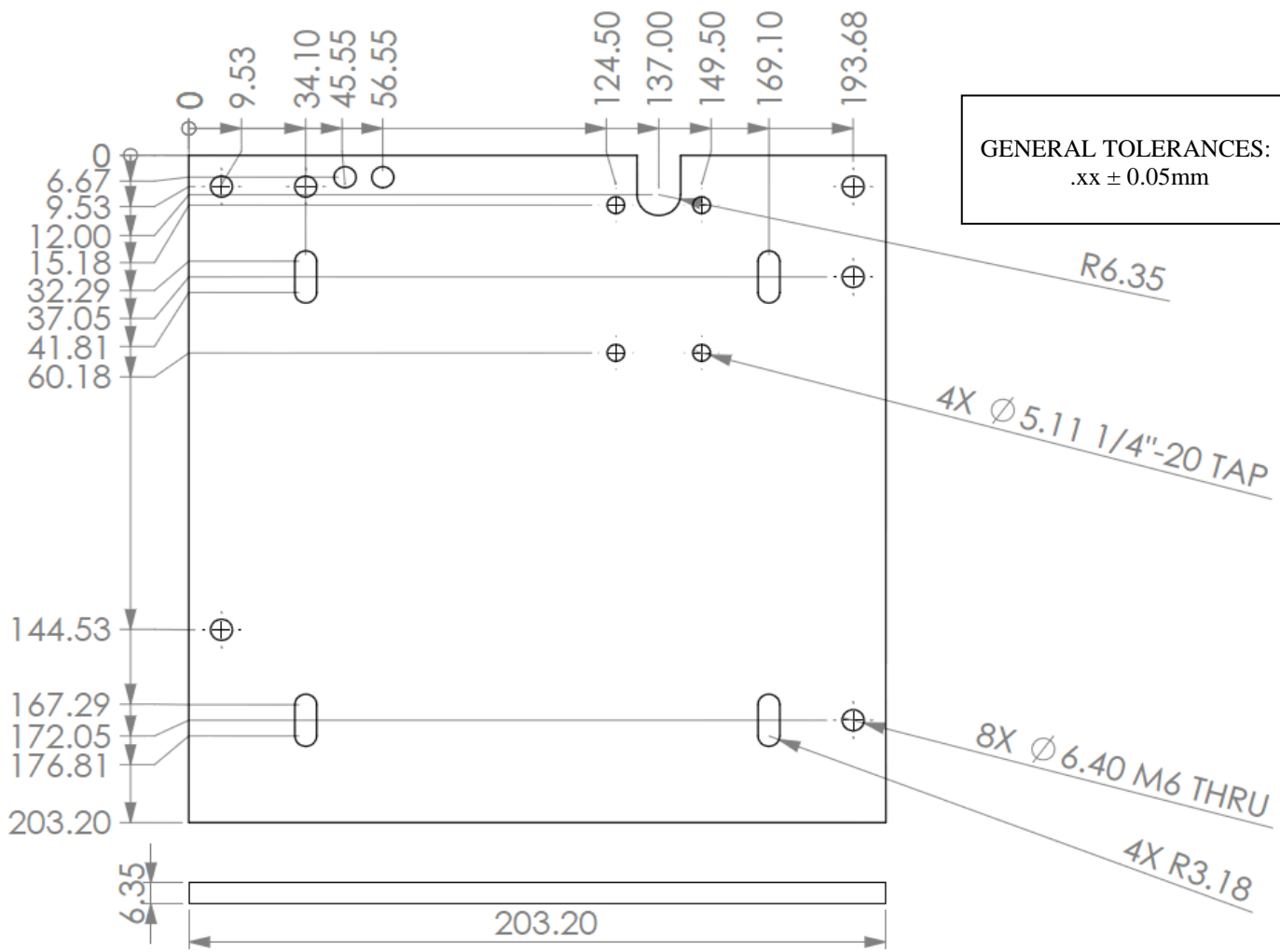


**PROPRIETARY AND CONFIDENTIAL**  
 THE INFORMATION CONTAINED IN THIS DRAWING IS THE SOLE PROPERTY OF <INSERT COMPANY NAME HERE>. ANY REPRODUCTION IN PART OR AS A WHOLE WITHOUT THE WRITTEN PERMISSION OF <INSERT COMPANY NAME HERE> IS PROHIBITED.

		UNLESS OTHERWISE SPECIFIED:		NAME	DATE
		DIMENSIONS ARE IN MILLIMETERS	DRAWN		
		TOLERANCES:	CHECKED		
		FRACTIONAL ±	ENG APPR.		
		ANGULAR: MACH ± BEND ±	MFG APPR.		
		TWO PLACE DECIMAL ±	Q.A.		
		THREE PLACE DECIMAL ±	COMMENTS:		
		INTERPRET GEOMETRIC TOLERANCING PER:			
		MATERIAL			
		6063 Aluminum			
		FINISH			
		None			
NEXT ASSY	USED ON				
APPLICATION		DO NOT SCALE DRAWING			

TITLE:  
**Sensor Support-Short**

SIZE	DWG. NO.	REV
<b>A</b>	<b>ME 450 12-4</b>	
SCALE: 1:2	WEIGHT:	SHEET 1 OF 1



GENERAL TOLERANCES:  
.xx ± 0.05mm

R6.35

4X Ø5.11 1/4"-20 TAP

8X Ø6.40 M6 THRU

4X R3.18

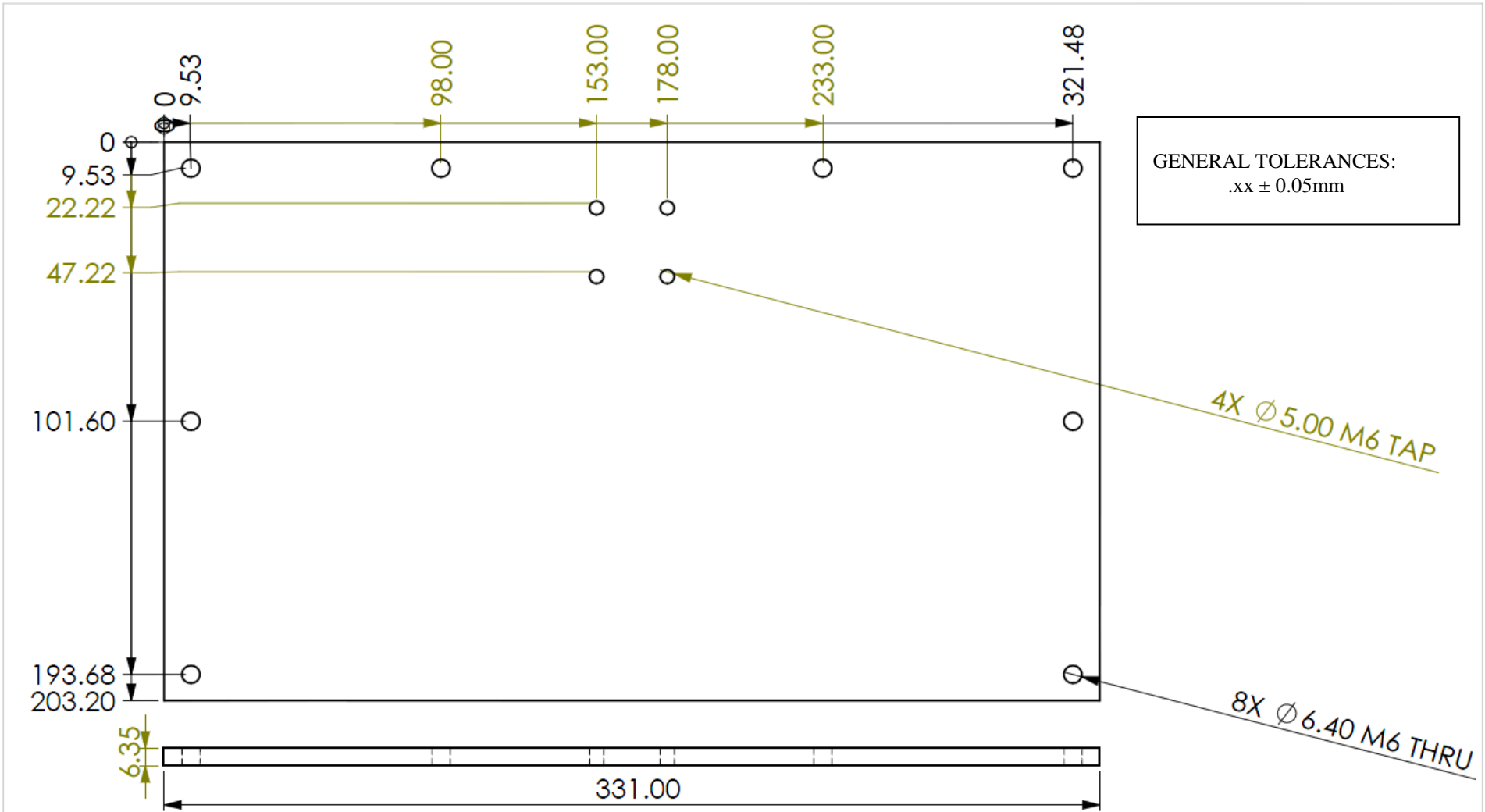
**PROPRIETARY AND CONFIDENTIAL**  
THE INFORMATION CONTAINED IN THIS DRAWING IS THE SOLE PROPERTY OF <INSERT COMPANY NAME HERE>. ANY REPRODUCTION IN PART OR AS A WHOLE WITHOUT THE WRITTEN PERMISSION OF <INSERT COMPANY NAME HERE> IS PROHIBITED.

		UNLESS OTHERWISE SPECIFIED:	NAME	DATE
		DIMENSIONS ARE IN MILLIMETERS	DRAWN	
		TOLERANCES:	CHECKED	
		FRACTIONAL ±	ENG APPR.	
		ANGULAR: MACH ± BEND ±	MFG APPR.	
		TWO PLACE DECIMAL ±	Q.A.	
		THREE PLACE DECIMAL ±	COMMENTS:	
		INTERPRET GEOMETRIC TOLERANCING PER:	WATERJET (IF AVAILABLE)	
		MATERIAL		
		6061 Aluminum		
		FINISH		
		None		
NEXT ASSY	USED ON	DO NOT SCALE DRAWING		
APPLICATION				

TITLE:  
**Side Plate- Cup**

SIZE	DWG. NO.	REV
<b>A</b>	ME 450 12-5	

SCALE: 1:2	WEIGHT:	SHEET 1 OF 1
------------	---------	--------------



GENERAL TOLERANCES:  
 .xx  $\pm$  0.05mm

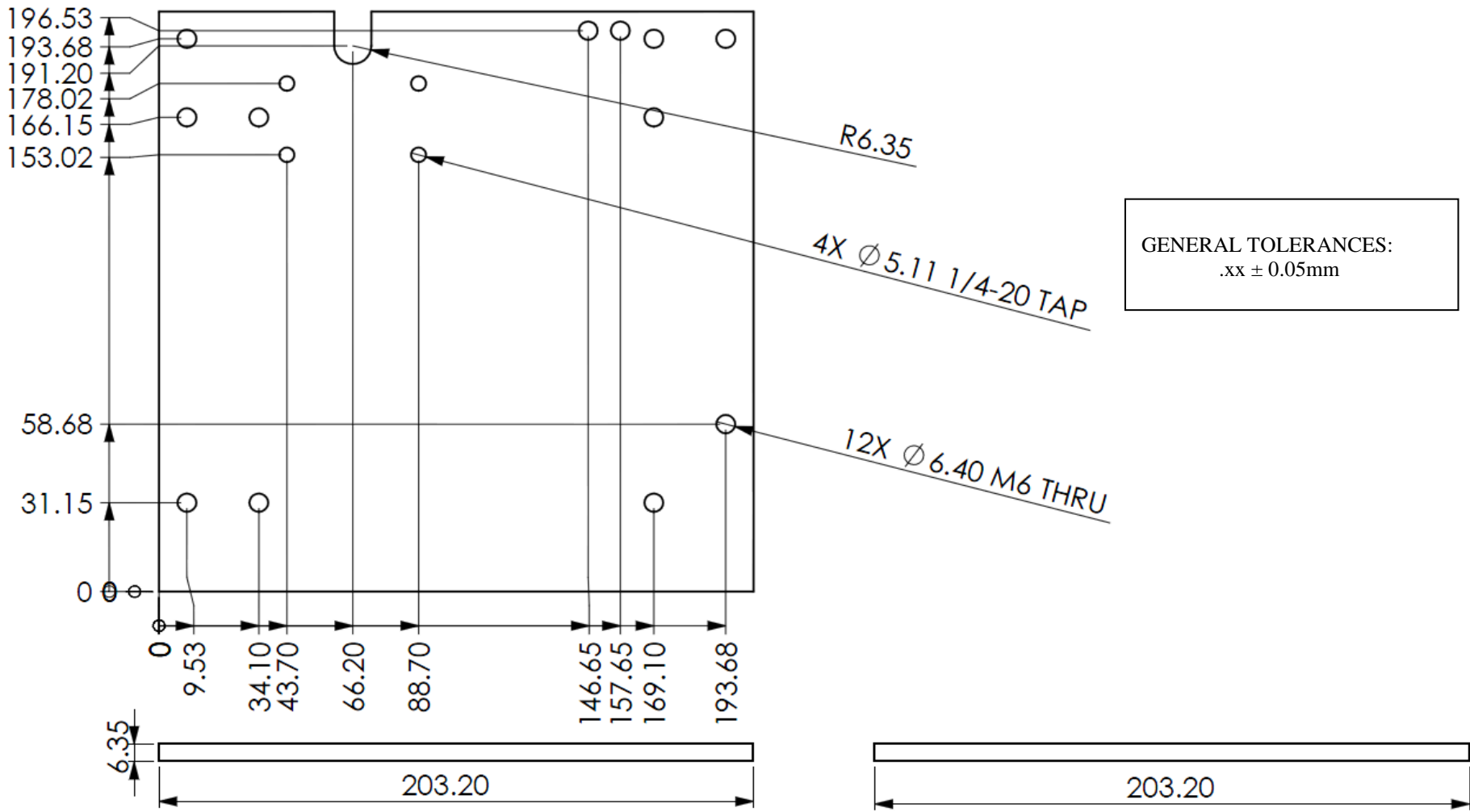
**PROPRIETARY AND CONFIDENTIAL**  
 THE INFORMATION CONTAINED IN THIS DRAWING IS THE SOLE PROPERTY OF <INSERT COMPANY NAME HERE>. ANY REPRODUCTION IN PART OR AS A WHOLE WITHOUT THE WRITTEN PERMISSION OF <INSERT COMPANY NAME HERE> IS PROHIBITED.

		UNLESS OTHERWISE SPECIFIED:	NAME	DATE
		DIMENSIONS ARE IN MILLIMETERS	DRAWN	
		TOLERANCES:	CHECKED	
		FRACTIONAL $\pm$	ENG APPR.	
		ANGULAR: MACH $\pm$ BEND $\pm$	MFG APPR.	
		TWO PLACE DECIMAL $\pm$	Q.A.	
		THREE PLACE DECIMAL $\pm$	COMMENTS:	
		INTERPRET GEOMETRIC TOLERANCING PER:	WATERJET (IF AVAILABLE)	
		MATERIAL		
		6061 Aluminum		
NEXT ASSY	USED ON	FINISH		
APPLICATION		None		
		DO NOT SCALE DRAWING		

TITLE:  
**Side Plate-Flat**

SIZE **A** DWG. NO. **ME 450 12-6** REV

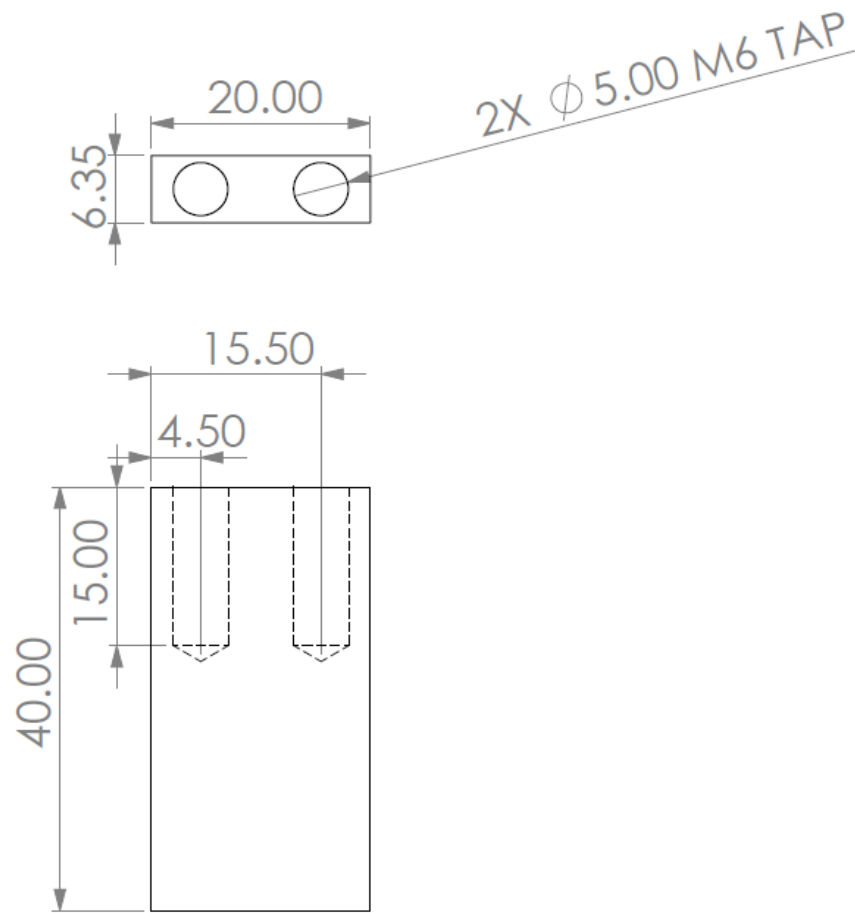
SCALE: 1:2 WEIGHT: SHEET 1 OF 1



**PROPRIETARY AND CONFIDENTIAL**  
THE INFORMATION CONTAINED IN THIS DRAWING IS THE SOLE PROPERTY OF <INSERT COMPANY NAME HERE>. ANY REPRODUCTION IN PART OR AS A WHOLE WITHOUT THE WRITTEN PERMISSION OF <INSERT COMPANY NAME HERE> IS PROHIBITED.

		UNLESS OTHERWISE SPECIFIED:	NAME	DATE
		DIMENSIONS ARE IN MILLIMETERS	DRAWN	
		TOLERANCES:	CHECKED	
		FRACTIONAL $\pm$	ENG APPR.	
		ANGULAR: MACH $\pm$ BEND $\pm$	MFG APPR.	
		TWO PLACE DECIMAL $\pm$	Q.A.	
		THREE PLACE DECIMAL $\pm$	COMMENTS:	
		INTERPRET GEOMETRIC TOLERANCING PER:	WATERJET (IF AVAILABLE)	
		MATERIAL		
		6061 Aluminum		
		FINISH		
		None		
		DO NOT SCALE DRAWING		

TITLE:		
Side Plate-V		
SIZE	DWG. NO.	REV
A	ME 450 12-7	
SCALE: 1:2	WEIGHT:	SHEET 1 OF 1



HOLE DEPTH TOLERANCE:  
+2mm/ -0mm

GENERAL TOLERANCES:  
.xx ± 0.10mm

**PROPRIETARY AND CONFIDENTIAL**  
THE INFORMATION CONTAINED IN THIS DRAWING IS THE SOLE PROPERTY OF <INSERT COMPANY NAME HERE>. ANY REPRODUCTION IN PART OR AS A WHOLE WITHOUT THE WRITTEN PERMISSION OF <INSERT COMPANY NAME HERE> IS PROHIBITED.

		UNLESS OTHERWISE SPECIFIED:		NAME	DATE	
		DIMENSIONS ARE IN MILLIMETERS	DRAWN			TITLE:  <b>Hard Stop</b>
		TOLERANCES:	CHECKED			
		FRACTIONAL ±	ENG APPR.			
		ANGULAR: MACH ± BEND ±	MFG APPR.			
		TWO PLACE DECIMAL ±	Q.A.			
		THREE PLACE DECIMAL ±	COMMENTS:			SIZE DWG. NO. REV
		INTERPRET GEOMETRIC TOLERANCING PER:				<b>A</b> ME 450 12-8
		MATERIAL 6061 Aluminum				SCALE: 3:2 WEIGHT: SHEET 1 OF 1
		FINISH None				
NEXT ASSY	USED ON	DO NOT SCALE DRAWING				
APPLICATION						

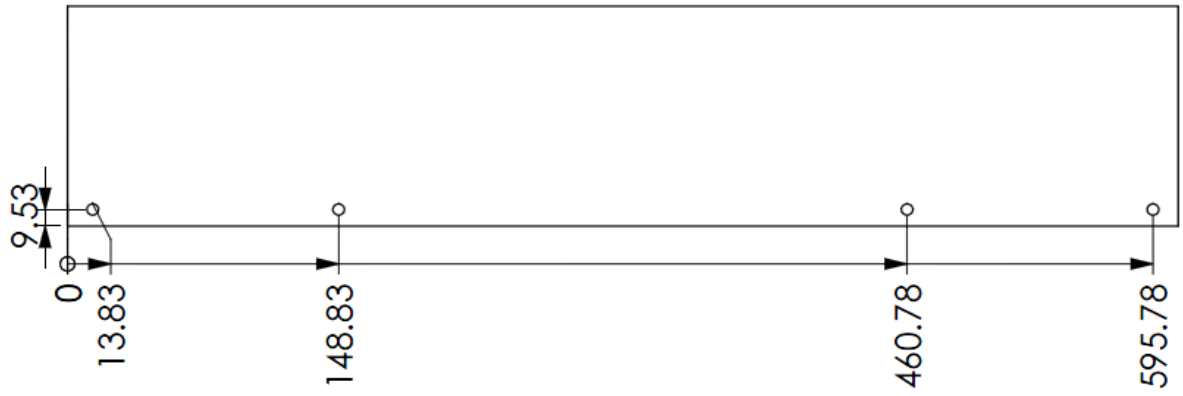
5

4

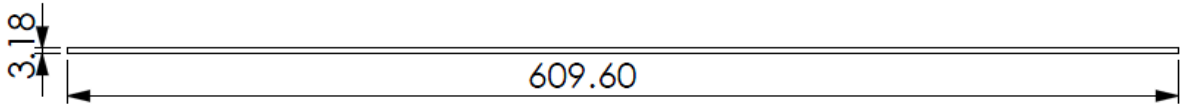
3

2

1



GENERAL TOLERANCES:  
 .x ± 0.2mm  
 .xx ± 0.05mm



**PROPRIETARY AND CONFIDENTIAL**  
 THE INFORMATION CONTAINED IN THIS DRAWING IS THE SOLE PROPERTY OF <INSERT COMPANY NAME HERE>. ANY REPRODUCTION IN PART OR AS A WHOLE WITHOUT THE WRITTEN PERMISSION OF <INSERT COMPANY NAME HERE> IS PROHIBITED.

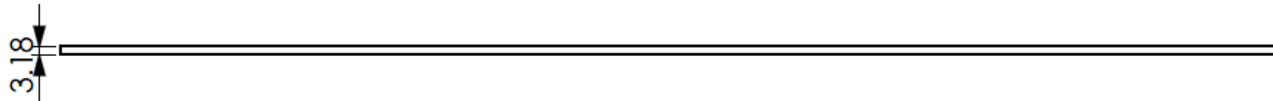
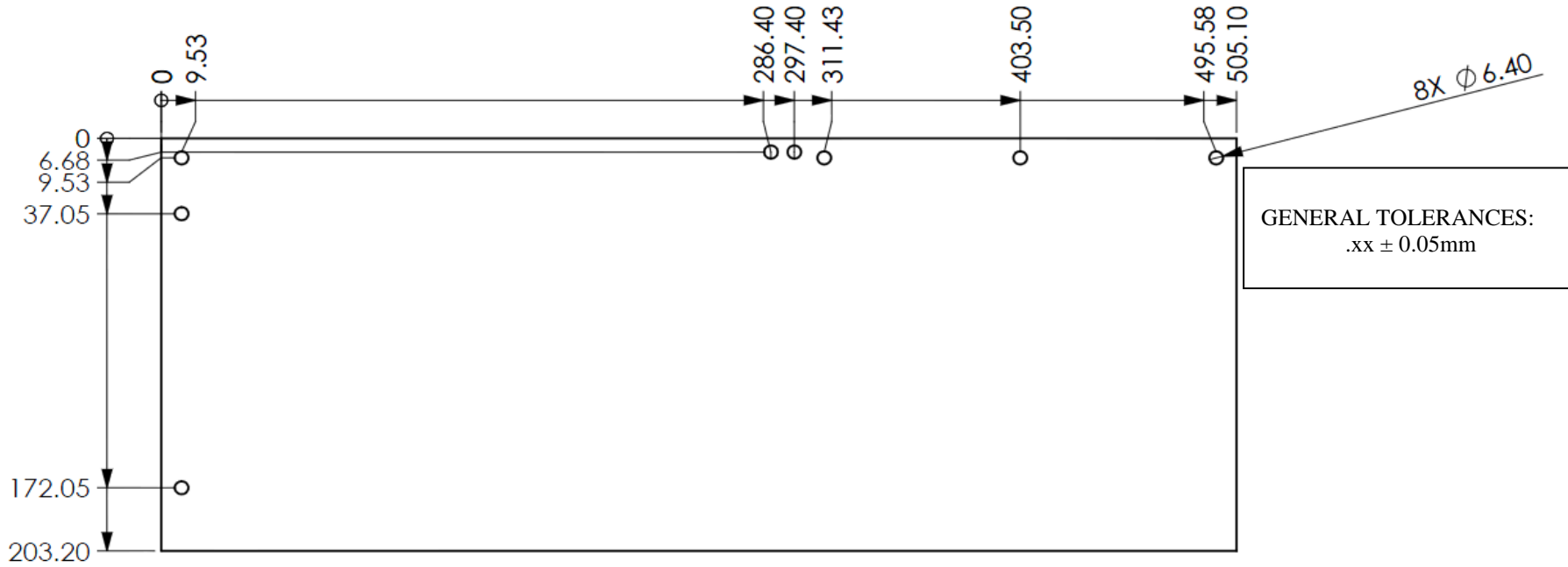
		UNLESS OTHERWISE SPECIFIED:		NAME	DATE
		DIMENSIONS ARE IN MILLIMETERS	DRAWN		
		TOLERANCES:	CHECKED		
		FRACTIONAL ±	ENG APPR.		
		ANGULAR: MACH ± BEND ±	MFG APPR.		
		TWO PLACE DECIMAL ±	Q.A.		
		THREE PLACE DECIMAL ±	COMMENTS:	DO NOT USE DRILL ON ACRYLIC	
		INTERPRET GEOMETRIC TOLERANCING PER:			
		MATERIAL	Acrylic		
NEXT ASSY	USED ON	FINISH	Black Paint		
APPLICATION		DO NOT SCALE DRAWING			

TITLE:  
**Sheet-Back**

SIZE DWG. NO. REV  
**A** ME 450 12-9

SCALE: 1:4 WEIGHT: SHEET 1 OF 1





**PROPRIETARY AND CONFIDENTIAL**  
 THE INFORMATION CONTAINED IN THIS DRAWING IS THE SOLE PROPERTY OF <INSERT COMPANY NAME HERE>. ANY REPRODUCTION IN PART OR AS A WHOLE WITHOUT THE WRITTEN PERMISSION OF <INSERT COMPANY NAME HERE> IS PROHIBITED.

		UNLESS OTHERWISE SPECIFIED:	NAME	DATE
		DIMENSIONS ARE IN MILLIMETERS	DRAWN	
		TOLERANCES:	CHECKED	
		FRACTIONAL ±	ENG APPR.	
		ANGULAR: MACH ± BEND ±	MFG APPR.	
		TWO PLACE DECIMAL ±	Q.A.	
		THREE PLACE DECIMAL ±	COMMENTS:	
		INTERPRET GEOMETRIC TOLERANCING PER:	DO NOT USE DRILL ON ACRYLIC	
		MATERIAL		
		FINISH		
NEXT ASSY	USED ON	Acrylic		
APPLICATION		Black Paint		
		DO NOT SCALE DRAWING		

TITLE:			
<h1>Sheet-Top</h1>			
SIZE	DWG. NO.	REV	
<b>A</b>	ME 450 12-10		
SCALE: 1:3	WEIGHT:	SHEET 1 OF 1	

5

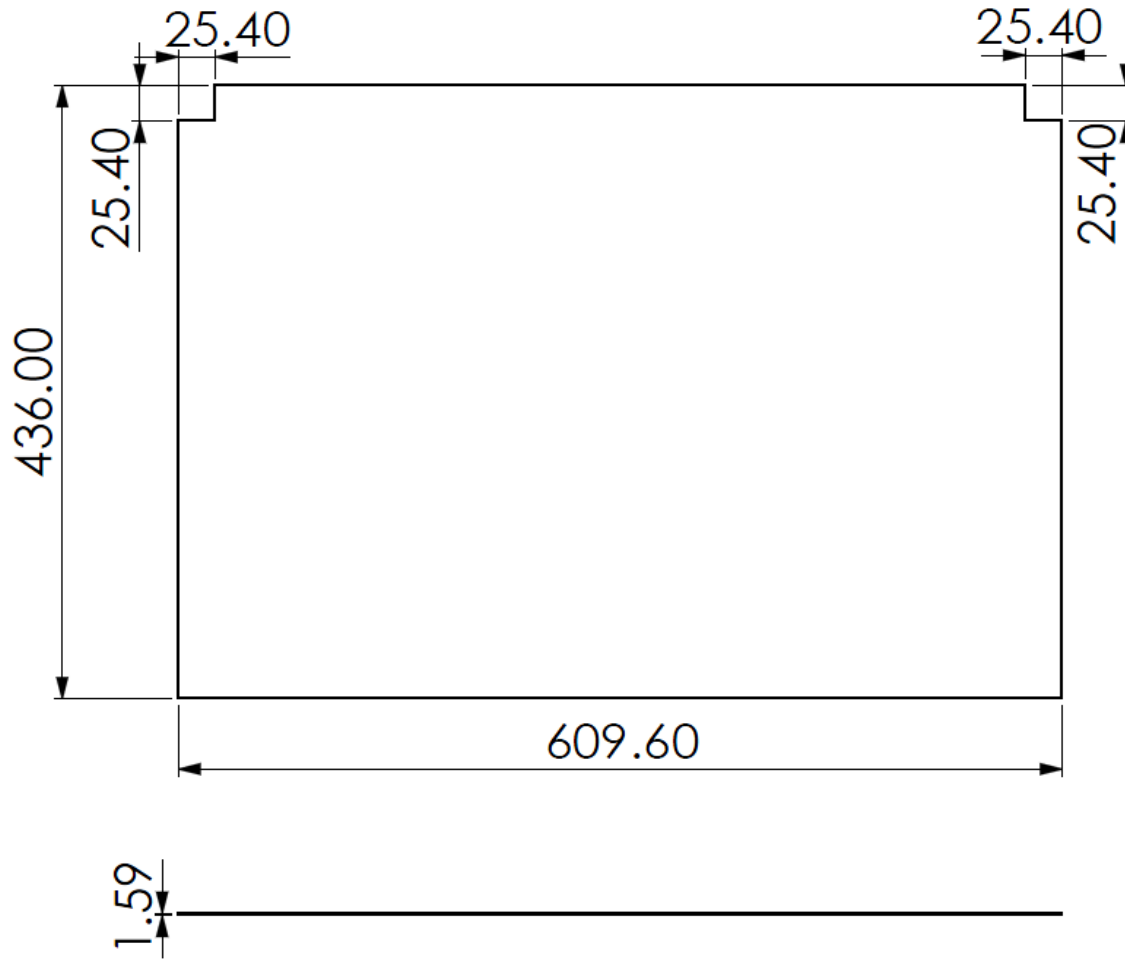
4

3

2

1

7

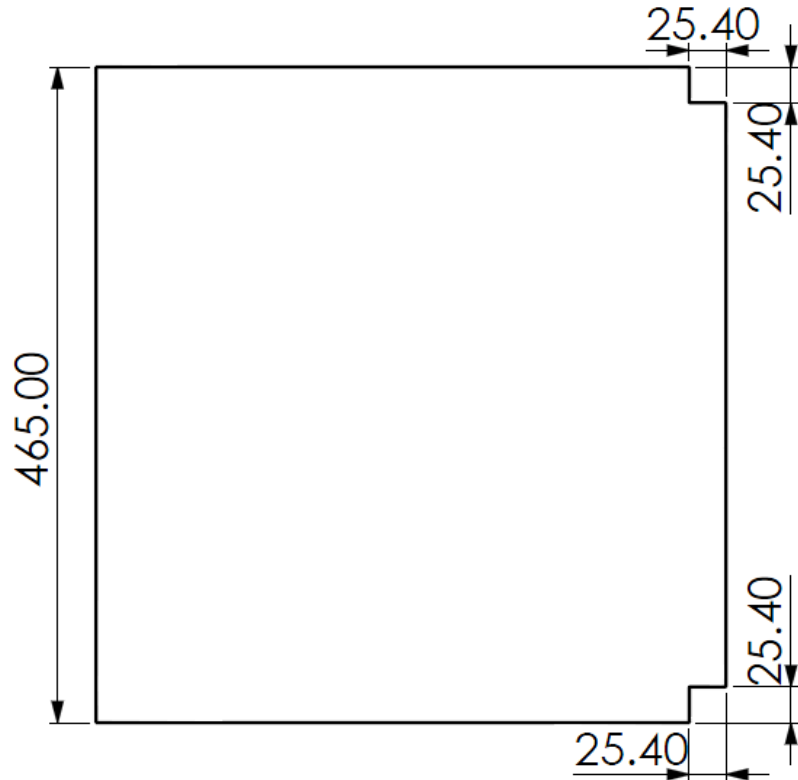


GENERAL TOLERANCES:  
 .x ± 0.2mm  
 .xx ± 0.05mm

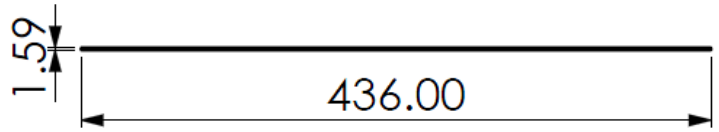
**PROPRIETARY AND CONFIDENTIAL**  
 THE INFORMATION CONTAINED IN THIS DRAWING IS THE SOLE PROPERTY OF <INSERT COMPANY NAME HERE>. ANY REPRODUCTION IN PART OR AS A WHOLE WITHOUT THE WRITTEN PERMISSION OF <INSERT COMPANY NAME HERE> IS PROHIBITED.

		UNLESS OTHERWISE SPECIFIED:		NAME	DATE
		DIMENSIONS ARE IN MILLIMETERS	DRAWN		
		TOLERANCES:	CHECKED		
		FRACTIONAL ±	ENG APPR.		
		ANGULAR: MACH ± BEND ±	MFG APPR.		
		TWO PLACE DECIMAL ±	Q.A.		
		THREE PLACE DECIMAL ±	COMMENTS:		
		INTERPRET GEOMETRIC TOLERANCING PER:			
		MATERIAL			
		Acrylic			
		FINISH			
		None			
NEXT ASSY	USED ON				
APPLICATION		DO NOT SCALE DRAWING			

TITLE:		
Wall-Side		
SIZE	DWG. NO.	REV
<b>A</b>	ME 450 12-11	
SCALE: 1:5	WEIGHT:	SHEET 1 OF 1

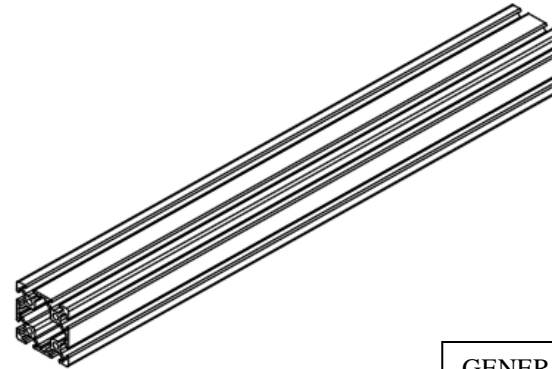
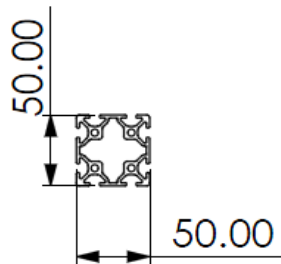
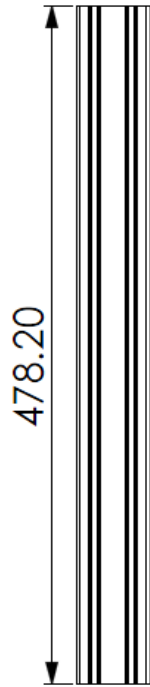


GENERAL TOLERANCES:  
 .x ± 0.2mm  
 .xx ± 0.05mm

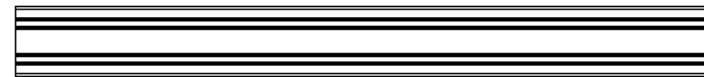


**PROPRIETARY AND CONFIDENTIAL**  
 THE INFORMATION CONTAINED IN THIS DRAWING IS THE SOLE PROPERTY OF <INSERT COMPANY NAME HERE>. ANY REPRODUCTION IN PART OR AS A WHOLE WITHOUT THE WRITTEN PERMISSION OF <INSERT COMPANY NAME HERE> IS PROHIBITED.

		UNLESS OTHERWISE SPECIFIED:		NAME	DATE			
		DIMENSIONS ARE IN MILLIMETERS		DRAWN		TITLE:  <b>Wall-Back</b>		
		TOLERANCES:		CHECKED				
		FRACTIONAL ±		ENG APPR.				
		ANGULAR: MACH ± BEND ±		MFG APPR.				
		TWO PLACE DECIMAL ±		Q.A.				
		THREE PLACE DECIMAL ±		COMMENTS:				
		INTERPRET GEOMETRIC TOLERANCING PER:				SIZE	DWG. NO.	REV
		MATERIAL				<b>A</b>	<b>ME 450 12-12</b>	
		FINISH				SCALE: 1:5		WEIGHT:
NEXT ASSY		USED ON				SHEET 1 OF 1		99
APPLICATION		DO NOT SCALE DRAWING						



GENERAL TOLERANCES:  
.xx ± 0.10mm



**PROPRIETARY AND CONFIDENTIAL**  
THE INFORMATION CONTAINED IN THIS DRAWING IS THE SOLE PROPERTY OF <INSERT COMPANY NAME HERE>. ANY REPRODUCTION IN PART OR AS A WHOLE WITHOUT THE WRITTEN PERMISSION OF <INSERT COMPANY NAME HERE> IS PROHIBITED.

		UNLESS OTHERWISE SPECIFIED:	NAME	DATE		
		DIMENSIONS ARE IN MILLIMETERS	DRAWN		TITLE:  <b>5050- Leg</b>	
		TOLERANCES:	CHECKED			
		FRACTIONAL ±	ENG APPR.			
		ANGULAR: MACH ± BEND ±	MFG APPR.			
		TWO PLACE DECIMAL ±	Q.A.		SIZE	DWG. NO.
		THREE PLACE DECIMAL ±	COMMENTS:		<b>A</b>	<b>ME 450 12-13</b>
		INTERPRET GEOMETRIC TOLERANCING PER:			REV	
		MATERIAL				
		<b>6061 Aluminum</b>			SCALE: 1:5	WEIGHT:
		FINISH				SHEET 1 OF 1
	NEXT ASSY	USED ON				
	APPLICATION					
			DO NOT SCALE DRAWING			

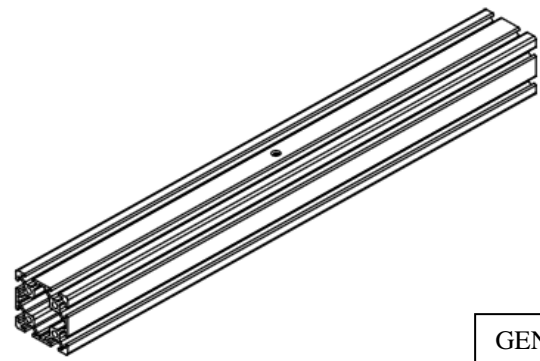
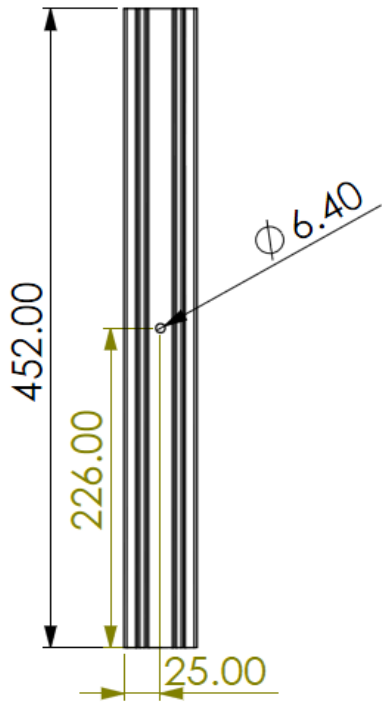
5

4

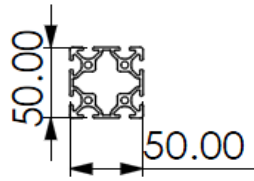
3

2

1



GENERAL TOLERANCES:  
.xx ± 0.10mm



**PROPRIETARY AND CONFIDENTIAL**  
THE INFORMATION CONTAINED IN THIS DRAWING IS THE SOLE PROPERTY OF <INSERT COMPANY NAME HERE>. ANY REPRODUCTION IN PART OR AS A WHOLE WITHOUT THE WRITTEN PERMISSION OF <INSERT COMPANY NAME HERE> IS PROHIBITED.

		UNLESS OTHERWISE SPECIFIED:		NAME	DATE			
		DIMENSIONS ARE IN MILLIMETERS	DRAWN			TITLE:  <b>5050-Front</b>		
		TOLERANCES:	CHECKED					
		FRACTIONAL ±	ENG APPR.					
		ANGULAR: MACH ± BEND ±	MFG APPR.					
		TWO PLACE DECIMAL ±	Q.A.					
		THREE PLACE DECIMAL ±	COMMENTS:			SIZE	DWG. NO.	REV
		INTERPRET GEOMETRIC TOLERANCING PER:				<b>A</b>	<b>ME 450 12-14</b>	
		MATERIAL	6061 Aluminum					
		FINISH				SCALE: 1:5	WEIGHT:	SHEET 1 OF 1
	NEXT ASSY	USED ON						
	APPLICATION		DO NOT SCALE DRAWING					

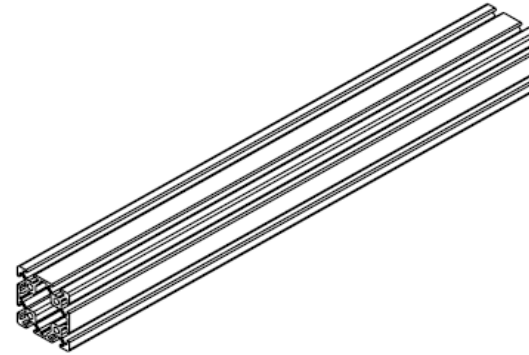
5

4

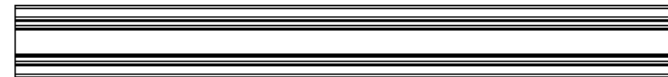
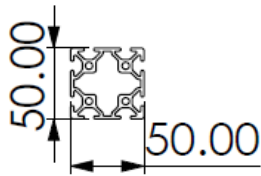
3

2

1



GENERAL TOLERANCES:  
.xx ± 0.10mm



**PROPRIETARY AND CONFIDENTIAL**  
THE INFORMATION CONTAINED IN THIS DRAWING IS THE SOLE PROPERTY OF <INSERT COMPANY NAME HERE>. ANY REPRODUCTION IN PART OR AS A WHOLE WITHOUT THE WRITTEN PERMISSION OF <INSERT COMPANY NAME HERE> IS PROHIBITED.

		UNLESS OTHERWISE SPECIFIED:		NAME	DATE	TITLE:  <b>5050-Back</b>							
		DIMENSIONS ARE IN MILLIMETERS	DRAWN					SIZE	DWG. NO.	REV			
		TOLERANCES:	CHECKED								<b>A</b>	<b>ME 450 12-15</b>	
		FRACTIONAL ±	ENG APPR.					SCALE: 1:5	WEIGHT:	SHEET 1 OF 1			
		ANGULAR: MACH ± BEND ±	MFG APPR.										
		TWO PLACE DECIMAL ±	Q.A.										
		THREE PLACE DECIMAL ±	COMMENTS:										
		INTERPRET GEOMETRIC TOLERANCING PER:											
		MATERIAL											
		<b>6061 Aluminum</b>											
		FINISH											
	NEXT ASSY	USED ON											
	APPLICATION		DO NOT SCALE DRAWING										

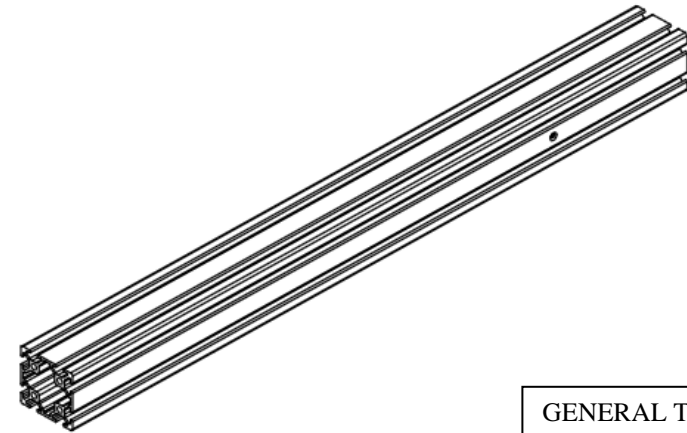
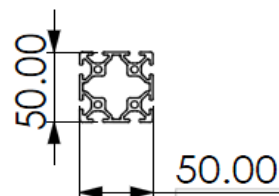
5

4

3

2

1



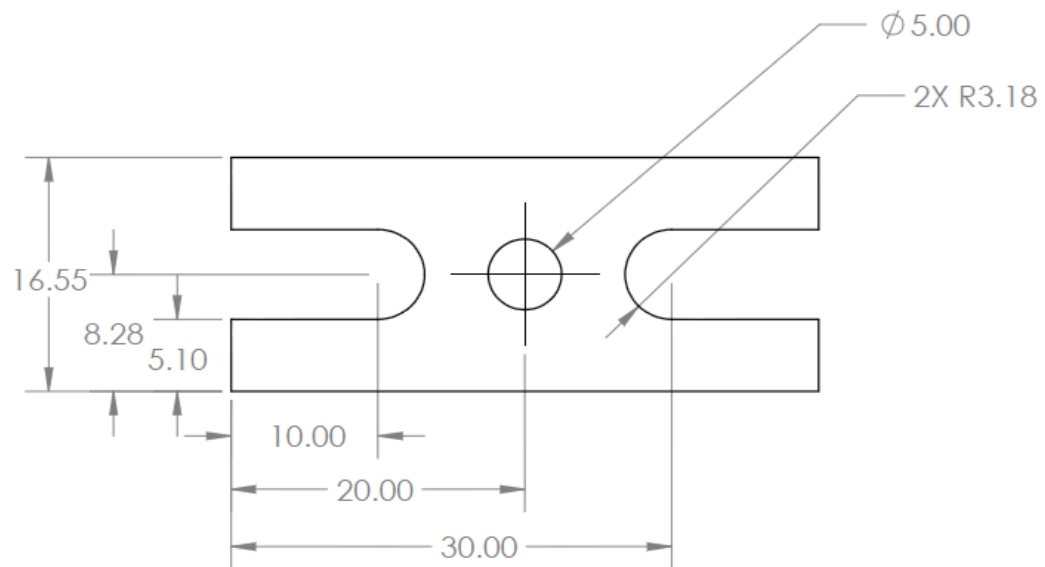
GENERAL TOLERANCES:  
.xx ± 0.10mm



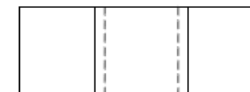
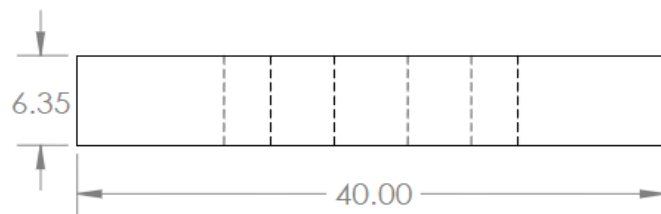
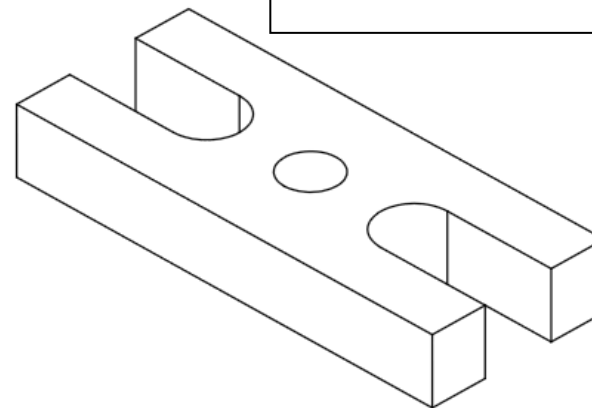
**PROPRIETARY AND CONFIDENTIAL**  
THE INFORMATION CONTAINED IN THIS DRAWING IS THE SOLE PROPERTY OF <INSERT COMPANY NAME HERE>. ANY REPRODUCTION IN PART OR AS A WHOLE WITHOUT THE WRITTEN PERMISSION OF <INSERT COMPANY NAME HERE> IS PROHIBITED.

		UNLESS OTHERWISE SPECIFIED:	NAME	DATE
		DIMENSIONS ARE IN MILLIMETERS	DRAWN	
		TOLERANCES:	CHECKED	
		FRACTIONAL ±	ENG APPR.	
		ANGULAR: MACH ± BEND ±	MFG APPR.	
		TWO PLACE DECIMAL ±	Q.A.	
		THREE PLACE DECIMAL ±	COMMENTS:	
		INTERPRET GEOMETRIC TOLERANCING PER:		
		MATERIAL	6061 Aluminum	
NEXT ASSY	USED ON	FINISH		
APPLICATION		DO NOT SCALE DRAWING		

TITLE:		
5050- Sides		
SIZE	DWG. NO.	REV
<b>A</b>	ME 450 12-16	
SCALE: 1:5	WEIGHT:	SHEET 1 OF 1



GENERAL TOLERANCES:  
 .x ± 0.2mm  
 .xx ± 0.05mm



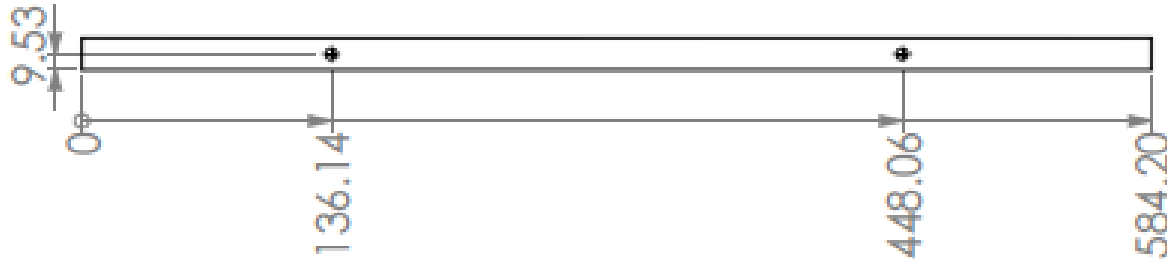
PROPRIETARY AND CONFIDENTIAL  
 THE INFORMATION CONTAINED IN THIS  
 DRAWING IS THE SOLE PROPERTY OF  
 <INSERT COMPANY NAME HERE>. ANY  
 REPRODUCTION IN PART OR AS A WHOLE  
 WITHOUT THE WRITTEN PERMISSION OF  
 <INSERT COMPANY NAME HERE> IS  
 PROHIBITED.

		UNLESS OTHERWISE SPECIFIED:		NAME	DATE
		DIMENSIONS ARE IN MILLIMETERS	DRAWN		
		TOLERANCES:	CHECKED		
		FRACTIONAL ±	ENG APPR.		
		ANGULAR: MACH ± BEND ±	MFG APPR.		
		TWO PLACE DECIMAL ±	Q.A.		
		THREE PLACE DECIMAL ±	COMMENTS:		
		INTERPRET GEOMETRIC TOLERANCING PER:			
		MATERIAL			
		6061 Aluminum			
		FINISH			
NEXT ASSY	USED ON	DO NOT SCALE DRAWING			
APPLICATION					

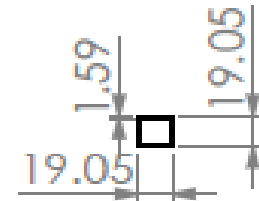
TITLE:  
**Ball Mount**

SIZE	DWG. NO.	REV
<b>A</b>	<b>ME 450 12-16</b>	
SCALE: 2:1	WEIGHT:	SHEET 1 OF 1





GENERAL TOLERANCES:  
 .xx ± 0.10mm



**PROPRIETARY AND CONFIDENTIAL**  
 THE INFORMATION CONTAINED IN THIS DRAWING IS THE SOLE PROPERTY OF <INSERT COMPANY NAME HERE>. ANY REPRODUCTION IN PART OR AS A WHOLE WITHOUT THE WRITTEN PERMISSION OF <INSERT COMPANY NAME HERE> IS PROHIBITED.

		UNLESS OTHERWISE SPECIFIED:	NAME	DATE	TITLE: <b>Handle Bar</b>
		DIMENSIONS ARE IN MILLIMETERS	DRAWN		
		TOLERANCES:	CHECKED		
		FRACTIONAL ±	ENG APPL.		
		ANGULAR: MACH ± BEND ±	MFG APPL.		
		TWO PLACE DECIMAL ±			
		THREE PLACE DECIMAL ±			
		INTERPRET GEOMETRIC TOLERANCING PER:	Q.A.		
		MATERIAL	COMMENTS:		
		Aluminum	Unknown Alloy (Scrap)		
		FINISH			SIZE <b>A</b> DWG. NO. <b>ME 450 12-17</b> REV
					SCALE: 1:4 WEIGHT: SHEET 1 OF 1
	NEXT ASSY	USED ON			
	APPLICATION				

5

4

3

2

1

## Appendix G: Manufacturing Processes and Steps

### 5. Manufacturing Processes

For all of the following processes, the cutting speed was determined by using the recommended cutting speed found at [1]. The cutting speed for aluminum is recommended to be around 300 fpm. To convert this speed into rpm, as is needed for use in a mill, we used the following equation (also found at [1]):

$$rpm = \frac{12V}{\pi d}$$

Where V is the velocity in feet per minute and d is the diameter in inches. We used two drill sizes for this project: a 5mm diameter and a 6.4mm diameter, which are the tapped hole and clearance sizes for M6 bolts, respectively. The 5mm bit has a recommended speed of 3800rpm and the 6.4mm is 3000rpm. The end mill that we will use for all the machined parts will be a half inch diameter end mill, which has a calculated recommended cutting speed of 1600rpm. A center drill is first used to pinpoint the location of each drilled hole and has a recommended cutting speed of 1800rpm [1]. However, the student machine shop recommends that we do not exceed 2000rpm, and even less is preferred. For this reason, we generally used the mill for most holes around 1600-1800rpm. With the exception of the water jet, all of the process described below were done in the ME machine shop in G. G. Brown. The water jetting was done in the Wu Manufacturing lab in DOW.

#### 5.1 T-Slotted Aluminum Framing

The T-slotted framing is made of 6061-T6 aluminum and all 8 pieces were cut to length by the supplier prior to shipping. Their default length tolerance is  $\pm \frac{1}{4}$  inch, but each of the same piece had precisely the same length (e.g. each leg was cut slightly shorter than specified, but each leg was the same length as the others within 0.01 inch). Three of the top pieces had  $\frac{1}{4}$ "-20 clearance holes drilled into them, as shown in part drawings 14 and 16. These holes are to help house the ball transfer units onto the support structure. The various tools and cutting speeds used can be seen in the table below.

Step	Operation	Machine	Cutting Tool	Cutting Speed	Notes
1	Locate Holes	Mill	Center Drill	1800 rpm	
2	Drill Holes	Mill	$\frac{1}{4}$ " drill bit	1600 rpm	Keep lubricated
3	Chamfer	Manual	Deburring tool	-	

#### 5.2 Aluminum Square Tubing

The square aluminum tubing is 6063-T5 aluminum that has a cross section of a  $\frac{3}{4}$ " square with an eighth inch thickness, coming as two 72" stock pieces. These two pieces were cut into 6 pieces with 5 cuts, into lengths as specified in drawings 1-4. First they should be cut to length with band saw, and then the ends squared off with a mill. Multiple holes were then drilled into the tops all the way through the bottom of the tube. **Note:** The handle bar (drawing 12-17) was

made from a scrap piece of square tubing found in the machine shop; it is a thinner tube than the rest. The manufacturing process is outlined below:

Step	Operation	Machine	Cutting Tool	Cutting Speed	Notes
1	Cut to Length Square Off	Band Saw	Band saw blade	300 fpm	
2	Part	Mill	1/2" end mill	1600 rpm	Keep lubricated
3	File Edges	Manual	File	-	
4	Find Holes	Mill	Center Drill 6.4mm drill bit	1600 rpm	Keep lubricated
5	Drill Holes	Mill		1600 rpm	
6	Chamfer	Manual	Deburring tool	-	

### 5.3 Aluminum Ball Transfer Plate

The material used for the ball transfer plates is 6061-T6 aluminum that comes in a 1/4" plate that is 8" x 36". It will make three complex components, complete with many holes and grooves, so we plan to use a water jet to simplify the machining process. However, we will not get the accuracy we require on certain holes (namely the smaller tapped holes), so we will also need to drill those separately using a mill and then tap them. The outer edges of the plate may also need to be trimmed with the mill, depending on how they look the water jet. (Note: if the 3foot plate exceeds the maximum allowable dimensions for the water jet, we can first use a band saw to cut the plate in twain at one of the plate boundaries)

Step	Operation	Machine	Cutting Tool	Cutting Speed	Notes
1	Cut to Shape	Water Jet	Water Jet	-	
2	File Edges	Manual	File	-	
3	Drill Holes	Mill	5mm drill bit	1600 rpm	Keep lubricated
4	Thread Holes	Manual	M6 Tap	-	

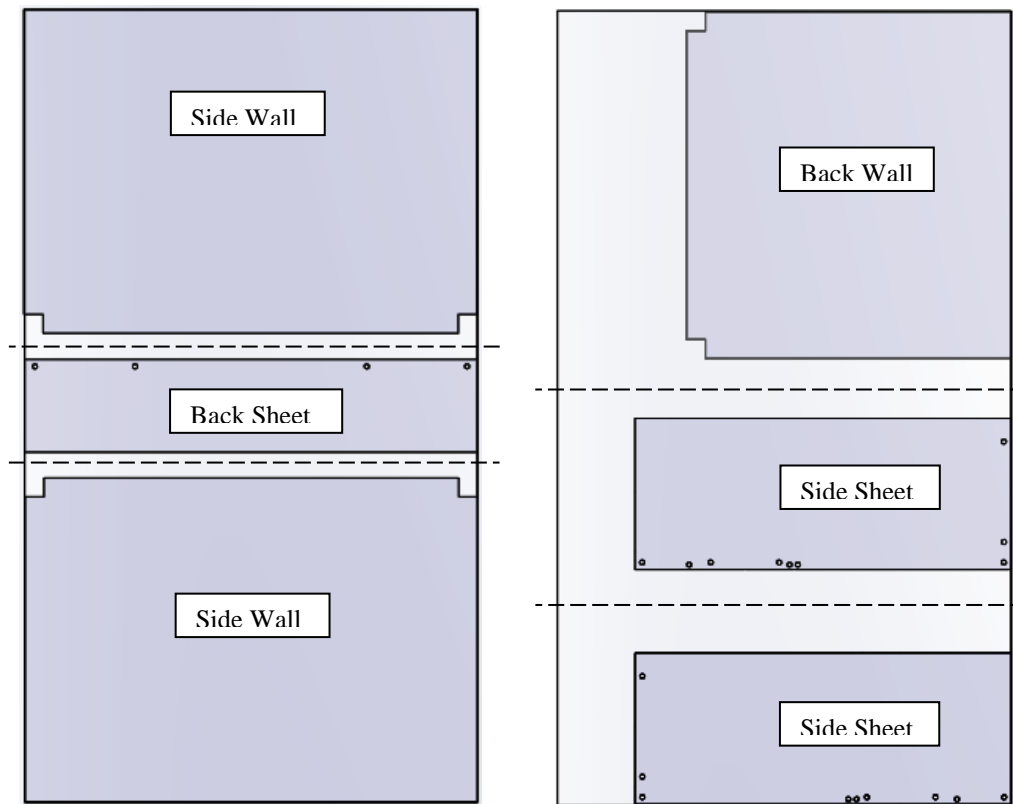
### 5.4 Hard Stops

The four hard stops for the sensor frame were created from the same 6061-T6 plate that was used to make the plates in the previous step. It can even be done in the same water jet session. However, it contains two blind holes in one of the sides that were not be able to be done in the water jet. Instead, we used a mill to make these holes, and then threaded them with a #10-32 tap. It will not need to have the ends squared off with the mill, since it is water jetted, but the edges should be filed down. The complete list of steps is shown in the table below.

Step	Operation	Machine	Cutting Tool	Cutting Speed	Notes
1	Cut to Shape	Water Jet	Water Jet	-	Same step as 5.3.1
2	File Edges	Manual	File	-	
3	Drill Holes	Mill	#21 drill bit	1600 rpm	Keep lubricated
4	Thread Holes	Manual	#10-32 Tap	-	

## 5.5 Hard Casing

The hard case that houses the structure will be made from four sheets of acrylic that are 18" by 24" and have a thickness of 0.09". These will be cut into the shapes as depicted in drawings 9-12. Two of the long walls will be made identical and two of the top front sheets will be identical. Since these are very thin sheets of acrylic, we can completely machine these components using the laser cutter in the machine shop. It should be noted that using a drill press or mill on such thin sheets of acrylic will fracture the plastic, rendering it unusable. Also, the protective film should be removed prior to laser cutting, as it may melt to the acrylic. The six pieces that will be used for the structure can be obtained from the two stock sheets using the layout below:



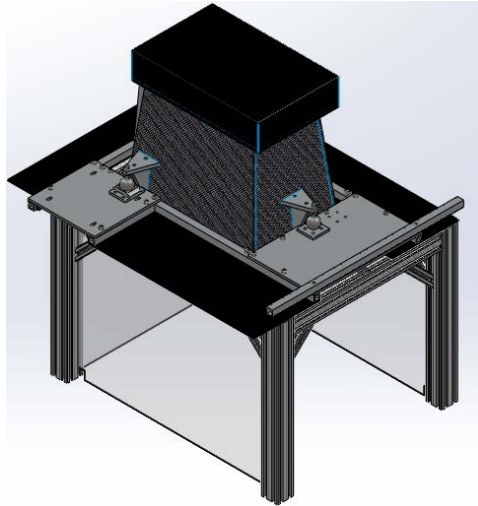
The first sheet of acrylic stock was used to make the two longer side walls (drawing 11) and the back sheet (drawing 9). The second sheet will be used to make the shorter back wall (drawing 12) and the top side sheets (drawing 10). The stock sheets are too large for some laser cutters, so some cuts need to be made with a band saw at 3600 fpm in the locations shown by dotted lines above.

Following the laser cutting, the back sheet and two side sheets will be colored black to block light using black spray paint. The paint we found to work the best is Krylon Fusion for Plastic in flat black. The paint should only be done on the bottom sides (facing the ground) for best results.

## Appendix H: Assembly Instructions

The final design for the demonstration unit for the S150 sensor has many components that must be put together in order for it to function. The fully assembled structure can be seen below in Figure 1. First we will outline the assembly instructions for two sub-assemblies: the support structure and the sensor frame. Each added item will be shown in blue.

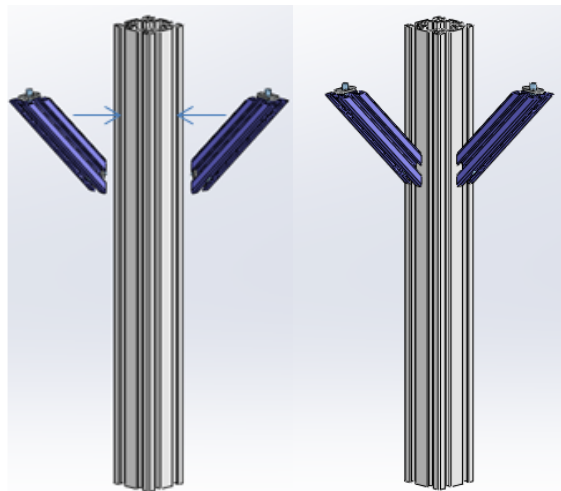
**Figure F.1:** The fully assembled structure CAD model



### Support Structure Sub-Assembly

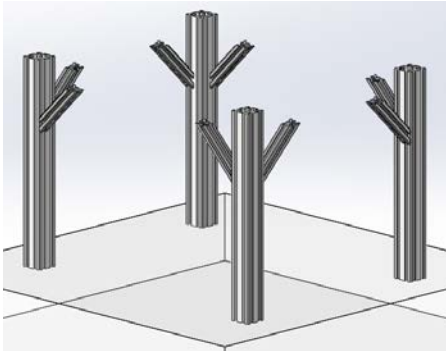
The support structure will sit atop a solid metrology table, and will serve as a foundation for the entire structure. It consists mainly of the T-slotted aluminum pieces, and can be assembled using the following steps:

1. Determine which T-slotted beams are the legs: they are the four beams of identical length, with no holes drilled in them. Attach two of the 45° T-slotted brackets to each leg, on opposite slots.



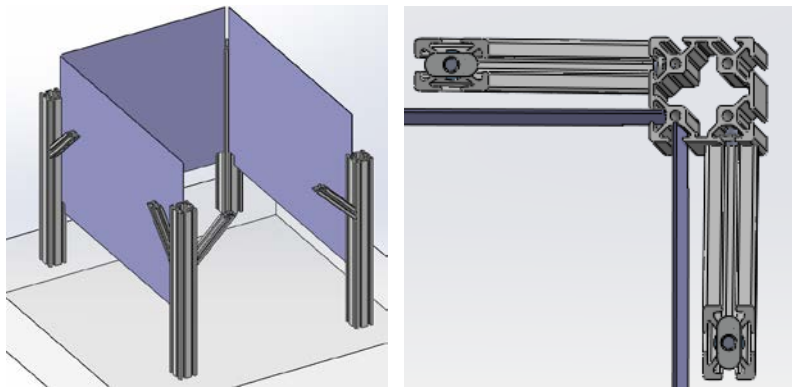
**Step 1**

2. Place the four legs with the attached brackets on a surface in the orientation shown in Figure 3. The brackets should all be pointing toward another leg.



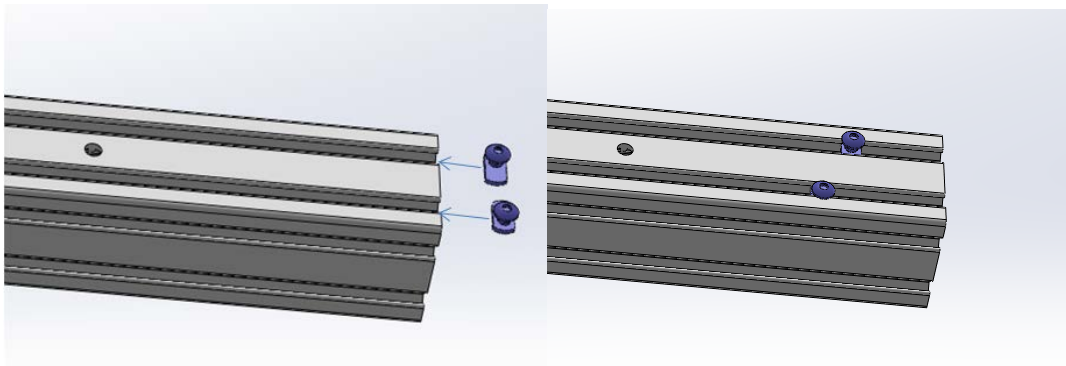
**Step 2**

3. Place the three large acrylic walls between the legs as shown in the figure below. The walls will be placed within the T-slots on the inside of the 45° supports. The small square notches should be down toward the table, where an end-feed fastener is placed to hold the walls in place.



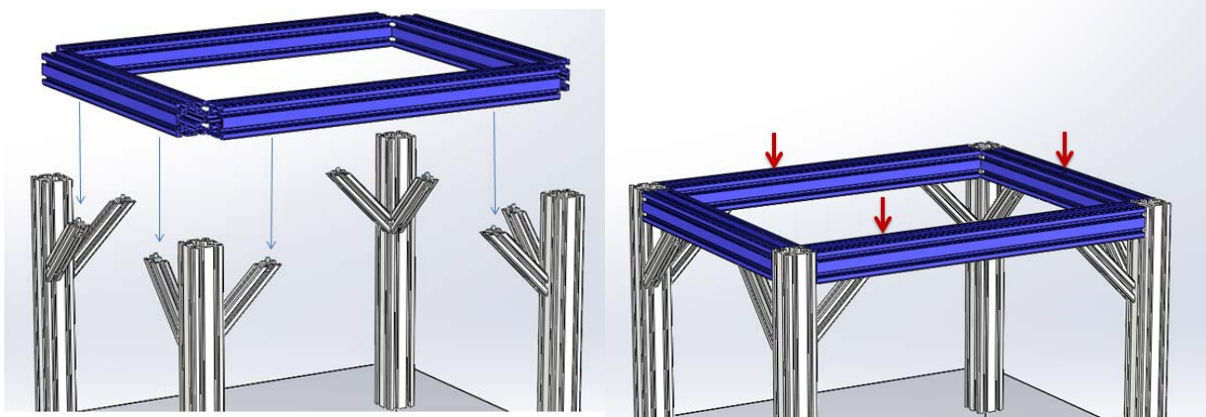
**Step 3**

4. The remaining beams will form a rectangle on top of these legs. Three of these beams have a single hole drilled into them. Place two end-feed fasteners in the grooves surrounding each hole (totaling 6 fasteners). It does not matter where they are on the beam at this time.



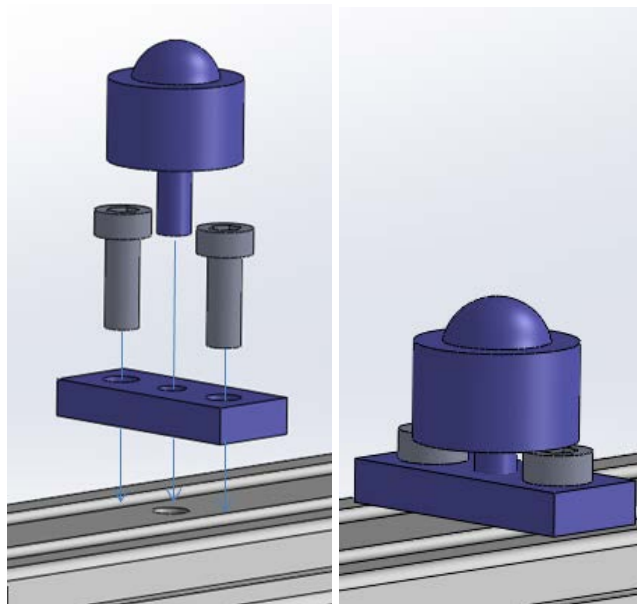
**Step 4**

5. Place the remaining beams on the legs above the acrylic walls using the fasteners built into the 45° brackets. There should be three holes on the top of the structure, oriented as shown in the figure below with red arrows. The short beam with the hole in the middle will be designated as the **front** of the structure from now on.



**Step 5**

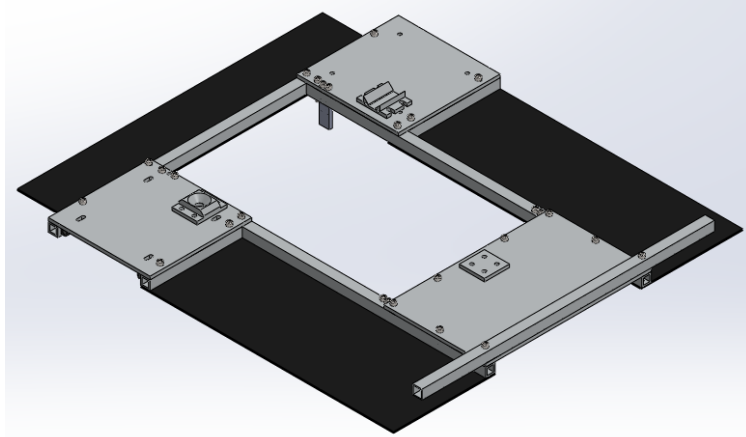
6. At each of the three holes along the top surface of the support structure, a ball transfer unit will be placed. Line up the end-feeds in the grooves surrounding the center hole, place the small ball plate centered along the hole, followed by the screws on the outer hole. Thread the ball transfer unit through the center hole until it is snug against the tops of the screws.



**Step 6**

## Sensor Frame Sub-Assembly

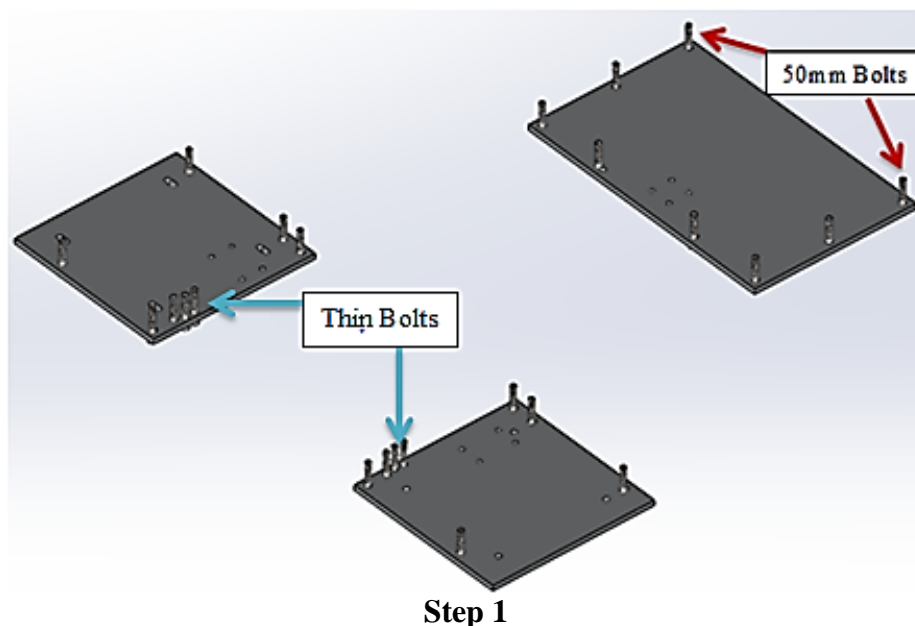
Next, the support frame that holds the sensor will be assembled. It consists of aluminum square tubing and plates, as well as acrylic plates and foam rubber. It also contains the three provided sensor mounts; the conical, V-groove, and flat plates. The final frame can be seen in Figure B below.



**Figure B:** The completed sensor support frame sub-assembly

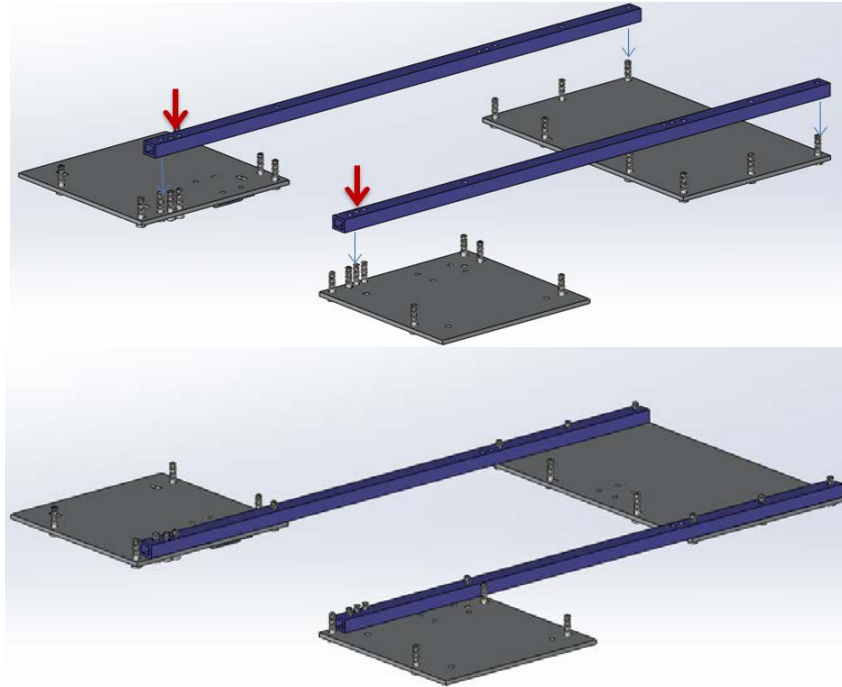
The support frame was assembled using the following steps:

1. Begin by placing the three plates face down as in the figure below. **Correct orientation is essential.** Put a bolt in each of the holes along the perimeter of each plate facing up (8 bolts on each plate, 24 total). The two marked with red arrows are the longer 50mm bolts, the rest are 35mm. The two off-centered pairs of bolts (blue arrows) are the *thinner* #10-32 bolts.



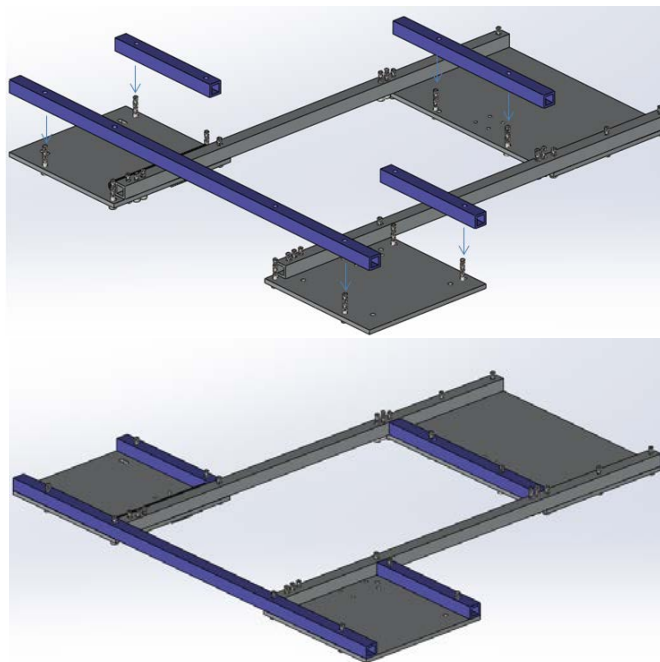


- The two square tubes with the most holes in it are the “side” beams. These will be placed as shown in the figure below. Make sure the off-center pair of holes are on the correct side, as noted by the red arrows.



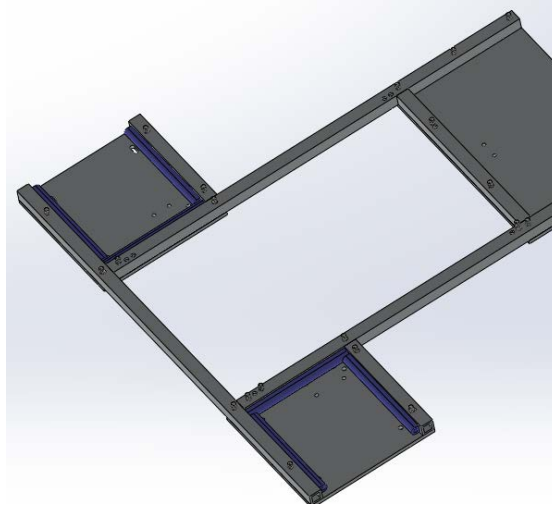
**Step 2**

- Fill in the rest of the beams where they fit, as shown below. The longest beam goes in the back, the shortest beams go on the smaller plates and the last beam goes on the larger plate. At this point there should be no bolts left open.



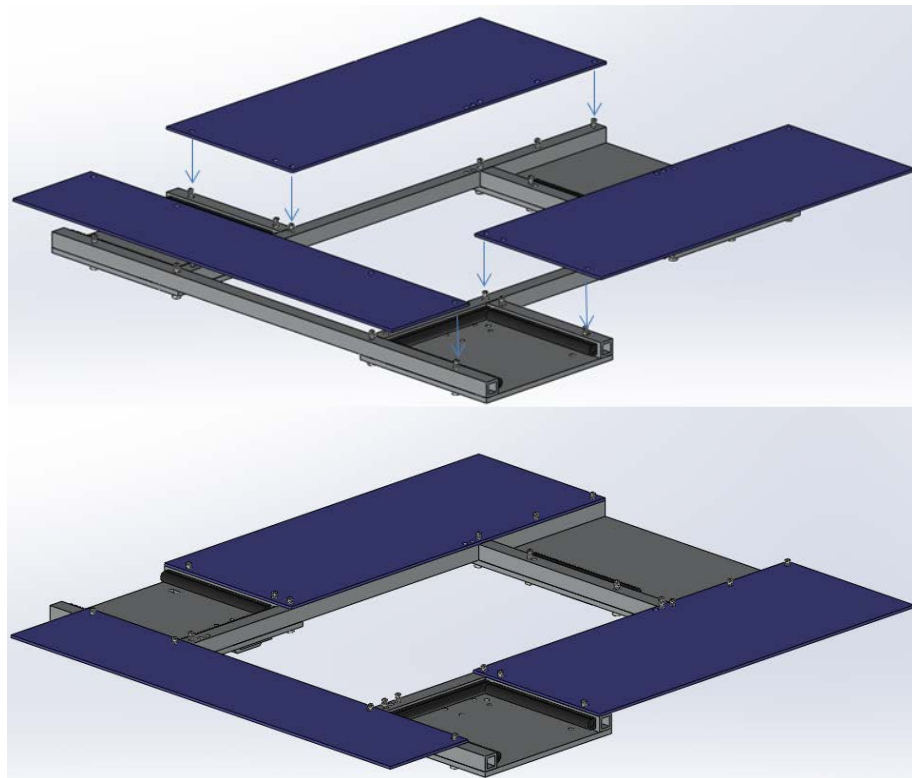
**Step 3**

4. Peel of the adhesive strip off of six foam rubber tubes cut to size and stick them around the perimeter of the smaller plates. Place the strips so that the wider edge of the “P” faces away from the plates.



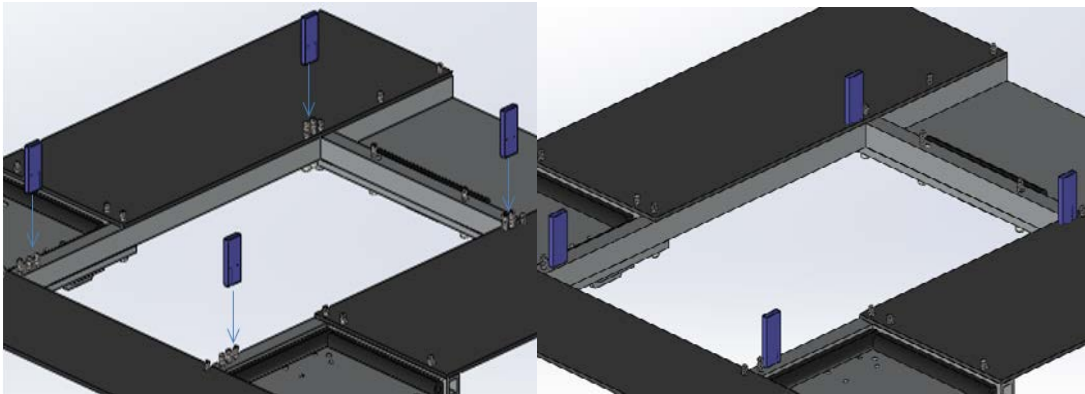
**Step 4**

5. Next, place the three acrylic sheets on the support beams as shown in the figure below. The thin rectangle attaches to the four bolts along the back beam, and the two wider rectangles attach to the L-shapes of the small beams and side beams. **At this point, secure all bolts with nuts** *except* for the four pairs of off-center bolts (they will be used for the hard stops in the next step)



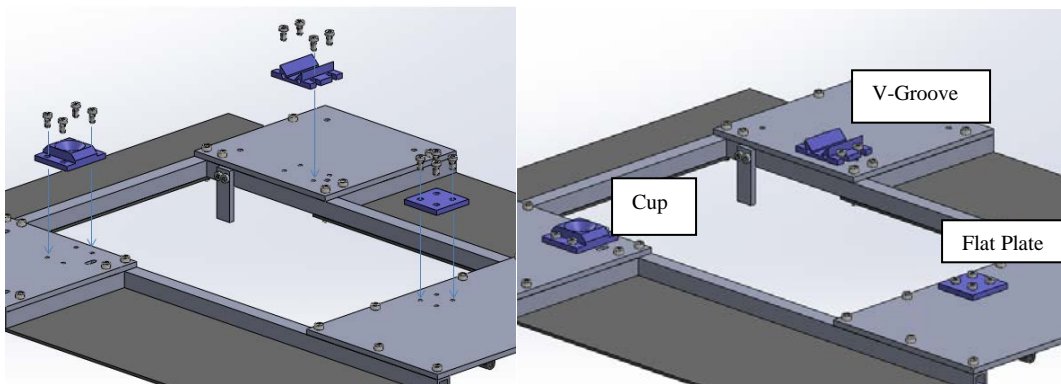
**Step 5**

6. Place the hard stops on each of the remaining bolt pairs. The order and orientation do not matter, as they are all symmetric. Use a screwdriver to thread the bolts into the hard stops. Remember that the hard stops use the longer, thinner #10-32 bolts.



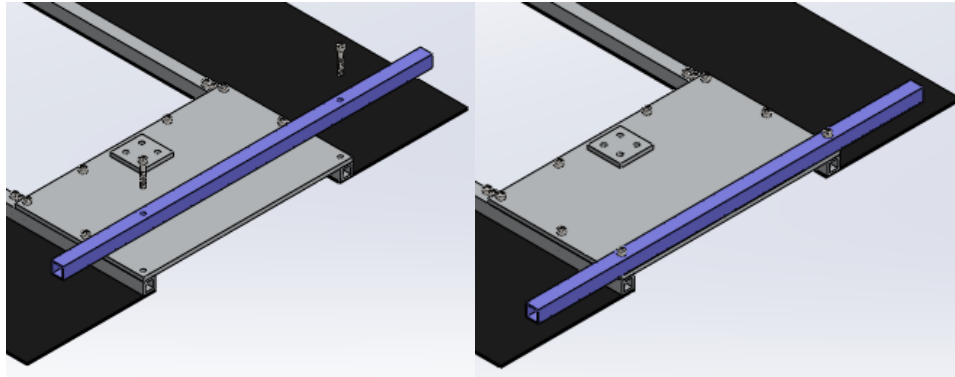
**Step 6**

7. Next, flip the structure over and place the three supplied mounts on the ball plates and fasten them in with the shorter 12mm screws. Again, **proper orientation is crucial**. See the figure below for proper placement.



**Step 7**

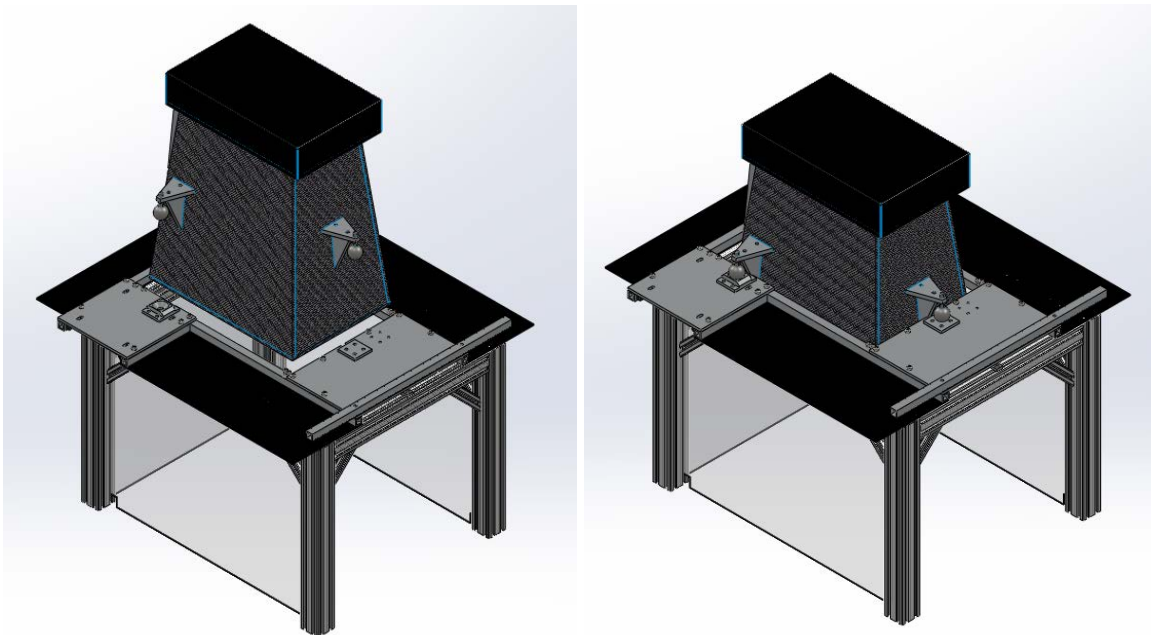
8. Finally, place the handle bar on the front of the larger front plate, as shown below. At this point, all nuts can be fully tightened. **Caution: the acrylic is prone to cracking if the bolts are tightened too much.**



**Step 8**

### Final Assembly

To finish assembling the S150 demonstration unit, the support structure is placed on a sturdy table, then the sensor frame is placed on top so that the three plates are resting atop the ball transfer units. Finally, the S150 can be placed on top of the sensor frame as shown below. The three balls on the sensor will rest on the three mounts: the V-Groove, the cup, and the flat plate, with the heat sink facing the back of the structure.



## Appendix I: Team Bios



On August 5, 1991 at 12am, a baby is born. His father named him Ahmad Syazwan Bin Ahmad Kamal, which is a very long name. Because of that long name, his father gave him an unofficial name, Juan. He was a very curious boy, he always asked about everything that happens around him, such as why a big steel structure can fly. After he finished high school, his father persuaded him to pursue the path of a medical doctor, but he refused. He loves to deal with machinery rather than human body. Then, he accepted a scholarship to further his studies in University of Michigan in Ann Arbor, Michigan. As a guy who loves jokes, he feels miserable because he doesn't understand most of the jokes here in Michigan. Everyone has a plan for the future, except him. He just follows the flow of life. He just hopes that he can have a fun mechanical engineering career in Malaysia.



Steve Christman was born January 19, 1990. He grew up in Mason, MI, a small town near Lansing. For most of his life, his parents owned their own tire repair business named J&B Tire Service. They repaired and replaced industrial and farm tires all over the Lansing area. Steve worked at the family business with his brother until it closed in September 2010. Working with heavy machinery was what made him interested in mechanical engineering. In the summer of 2012, he worked as an intern at Guardian Automotive, an automotive glass manufacturer. He

worked with Program Management to assist with the launch of several new products for Chrysler vehicles. He spent a lot of time of his time in manufacturing plants, gaining valuable hands on experience. Steve will be graduating in December 2012 and will be entering the workforce. He hopes to find a job in Michigan in the automotive industry. Ideally, he would work as an engineer in a manufacturing environment and eventually work his way into program management.



David Doman is a born-and-raised Ann Arborite who never got a chance to leave his hometown. More accurately, he is from just north of north campus. Mechanical engineering is sort of his family trade. His dad is a mechanical engineer, and so was his grandpa, and great grandfather, etc. All of them ended up working in the automotive industry, so David's best laid plans are to end up doing the same. It doesn't matter where exactly, but product development would be nice. He has been a janitor (or "maintenance technician") for the past four years. Beyond the scope of math and learning, David is also a musician at heart. He is in a few rock bands, one of which is even mildly successful in the local market, as lead guitarist/ backup vocalist, but he can also play most other instruments (and he's obviously very modest about it). So if the whole "engineering" thing doesn't work out for him, at least he has "being an old washed-up musician" to fall back on

