

## THE CONTROL AND RECORDING OF RESPONSE FORCE<sup>1</sup>

JOHN L. FALK AND WALTER O. HAAS, III

THE UNIVERSITY OF MICHIGAN

As part of a program to evaluate the motor capacities of rats with various central nervous system deficits, we have assembled, tested, and used for six months, components constituting a force-lever system. The original article by Notterman (1959) yields few apparatus details, although with the incorporation of an analog computer his system is potentially more versatile than the one presented here. Our system has a considerable price advantage, is directly compatible with standard relay equipment, and is easily programmed by personnel familiar with switching-circuit programming techniques. It has capabilities to reinforce differentially within two separate, adjustable force bands or provide any control function dependent upon four adjustable force limits. A complete analog record of force is available for finer analysis. Hefferline, Birch, and Gentry (1961) have constructed a type of transducer suitable for some force-lever applications. The recording system they describe, a recording milliammeter, suffers from the drawbacks of all such systems, *viz.*, inductive reactance, overshoot, and lack of frequency response. The control aspects of the system consist of biased thyatron tubes with their inherent problems of aging and continual recalibration. Calibration of their transducer revealed nonlinearity and large changes between pre- and post-session calibration curves.

The force-lever apparatus (Fig. 1) consists of a force transducer<sup>2</sup> operandum, an ampli-

fier and associated limit-detecting circuits,<sup>3</sup> an oscillograph,<sup>4</sup> a patch box and filter constructed by us, and switching circuits to control stimulus and reinforcement schedules. The oscillograph is a dual-channel model, but a single-channel oscillograph of similar speed, frequency response, and 25 mv full-scale sensitivity could be used.

The force transducer is a housing containing a variable transformer of a type known as the LVDT (Linear Variable Differential Transformer). In the core of this transformer, a fine iron rod is free to move back and forth along its axis within the transducer. Displacement of this rod in either direction from center is opposed by an internal spring which exerts a force proportional to the displacement (100 g per 0.01"). Any displacement of the core produces a proportionate change in the electrical properties of the transformer.

The amplifier output drives both the limit-detecting circuits and the oscillograph. The limit detector has as its output the contacts of four independent relays. Each of these relays can be set to operate whenever the input voltage to the limit detector is in excess of some value; that value is selected by a potentiometer associated with each relay. Thus, when the limit detector is used in conjunction with the force transducer and amplifier, each relay in the limit detector will be in the operated condition whenever the force applied to the transducer is in excess of the value selected for that relay. These force

<sup>1</sup>This research was supported by the United States Public Health Service Grant B 3861, Atomic Energy Commission Contract AT(11-1) 1201, and United Cerebral Palsy. Reprints may be obtained from John L. Falk, Department of Pathology, The University of Michigan, Ann Arbor, Michigan 48104.

<sup>2</sup>Sanborn Microforce Transducer model FTA-100-1. Transducer Division, Sanborn Company, 175 Wyman Street, Waltham 54, Massachusetts.

<sup>3</sup>Daytronics model 300CL-4XL with plug-in strain gauge amplifier type 81XL (plug-in modified by factory for above transducer). Daytronic Corporation, 2875 Culver Avenue, Dayton (Kettering) 29, Ohio.

<sup>4</sup>Texas Instruments model P2CBN "Oscillo/riter" ink-writing medium frequency two-channel recorder with two plug-in, high-gain dc input amplifiers (without optional zero suppression). Texas Instruments, Inc., 3609 Buffalo Speedway, Houston, Texas 77006.

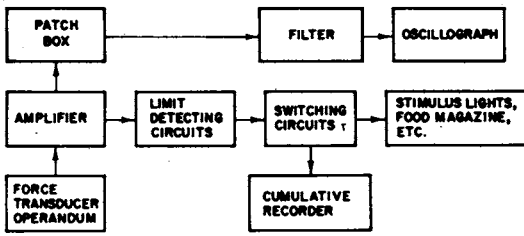

Fig. 1. Force lever diagram.

detectors may then be set to define force bands for reinforcement, etc.

The operation of the limit detector does not depend upon meter response time, which is comparatively slow. They are not "meter relays" and have a response time not greater than 50 msec. With the meter shorted out for recording purposes (see next paragraph), the output response time is improved to 16 msec.

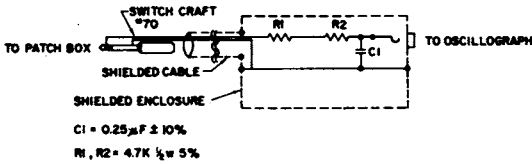
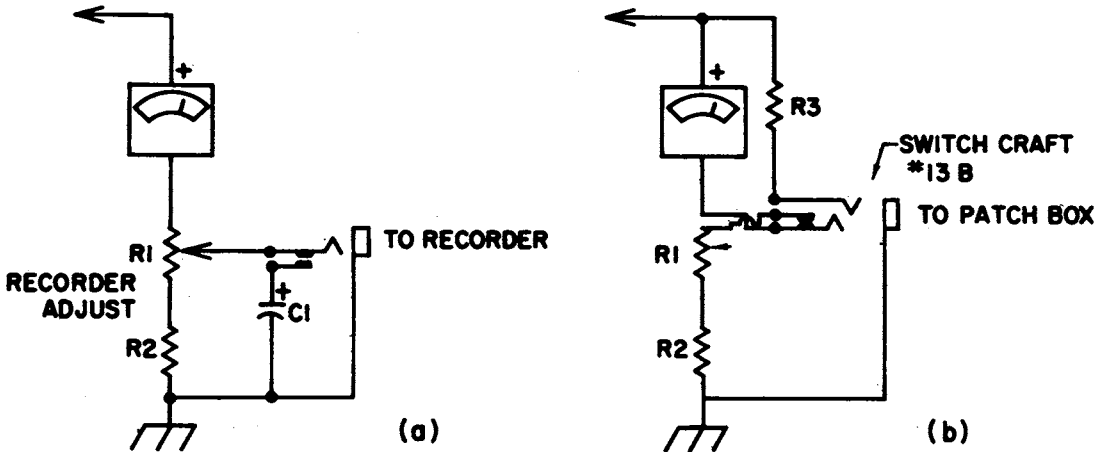

Fig. 2. Schematic diagram of filter.

The oscillograph is driven by the amplifier through a low-pass filter. The low-pass filter

(Fig. 2) limits the maximum rate of change of the input signal to the oscillograph to a level which can be clearly recorded. The inductance of the meter in the output circuit of the amplifier produces a spurious signal whenever the current through it changes. To provide a true signal to the oscillograph, it was necessary to remove this meter from the circuit. This was done with a simple modification to the amplifier (Fig. 3) and a patch box (Fig. 4). The patch box provides a switch to connect the meter (for calibration) or replace it with a resistor (for operation). In calibration, the oscillograph is connected, the patch box switch is set to "calibrate", and a signal is injected so that the oscillograph pen deflects about half-way. This deflection is noted. Then the switch is turned to "operate", and the "balance" control is adjusted until the pen returns to its former position. Then the "re-corder level" control is adjusted for a convenient correspondence between force and pen deflection.

It was necessary to shield the amplifier from the magnetic fields of the relays in the switching circuits, and also to filter the ac power line to the amplifier. A Sorensen model 1000-S ac voltage regulator provides controlled and filtered power to the amplifier and several



- $C1 = 50 \mu F$
- $R1 = 100 \Omega$
- $R2 = 22 \Omega$
- $R3 = 12 \Omega, \frac{1}{2} w 5 \%$
- METER = 500-0-500  $\mu A$

Fig. 3. Meter circuit and recorder output of Daytronics Model 300 CL amplifier, (a) as supplied, (b) after modification.

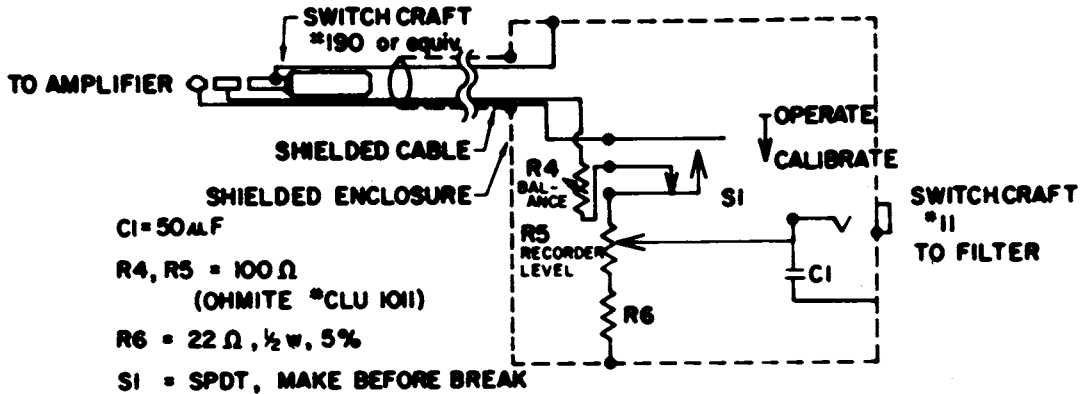

Fig. 4. Schematic diagram of patch box.

other pieces of apparatus, but a regulator with a lower power rating would be adequate for the amplifier alone.

The transducer drive rod was positioned with its axis at a right-angle to the back leaf of a Gerbrands rat lever, which was modified to prevent lateral creep of the lever about its pivot. The pivot was lubricated with silicone grease. A tiny air gap was left between the drive rod and the leaf so that the transducer remained unloaded when the lever was not being operated. The lever was counterbalanced so that it required a force of 2 g to bring the leaf into contact with the drive rod. A steel shield enclosing the lever exposes only a 13 mm wide section of the central, upper surface of the lever for the animal.

considered to have terminated when this same limit switch becomes unoperated. In this example, all responses falling within the 15-20 g force band were reinforced. Response A is below band, B is adequate, and C is above band and is, of course, not reinforced. Response consequences are initiated when the 5-g limit switch becomes unoperated.

The settings of the limit switches should be checked several times during the first few weeks of operation. We have found that all these settings drift up slightly during this time, presumably with initial aging of the "Nuvistor" tubes in the Daytronics unit.

The cost of the transducer and modified Daytronics equipment comes to a little over \$1000.

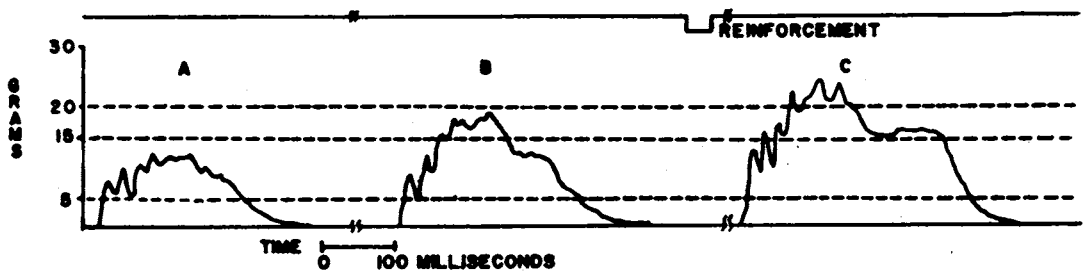

Fig. 5. Sample responses of rat. A: Response below reinforcement band. B: Reinforced response. C: Response above reinforcement band.

Figure 5 shows examples of responses recorded from rat I-41, 9-3-64, on the Oscillo/riter at 125 mm per sec. The dashed lines represent settings of three of the limit switches. A response is defined by a force sufficient to operate the first limit switch (5 g) and is con-

## REFERENCES

- Hefferline, R. F., Birch, J. P., and Gentry, T. Simple transducers to detect or record operant amplitude. *J. exp. Anal. Behav.*, 1961, 4, 257-261.
- Notterman, J. M. Force emission during bar pressing. *J. exp. Psychol.*, 1959, 58, 341-347.